



Viking CCS pipeline

## 4.17 Standard Trench Excavation Details

Document Reference: EN070008/APP/4.17

Applicant: Chrysaor Production (U.K.) Limited,  
a Harbour Energy Company  
PINS Reference: EN070008  
Planning Act 2008 (as amended)  
The Infrastructure Planning (Applications: Prescribed Forms  
and Procedure) Regulations 2009 - Regulation 5(2)(o)  
Date: October 2023

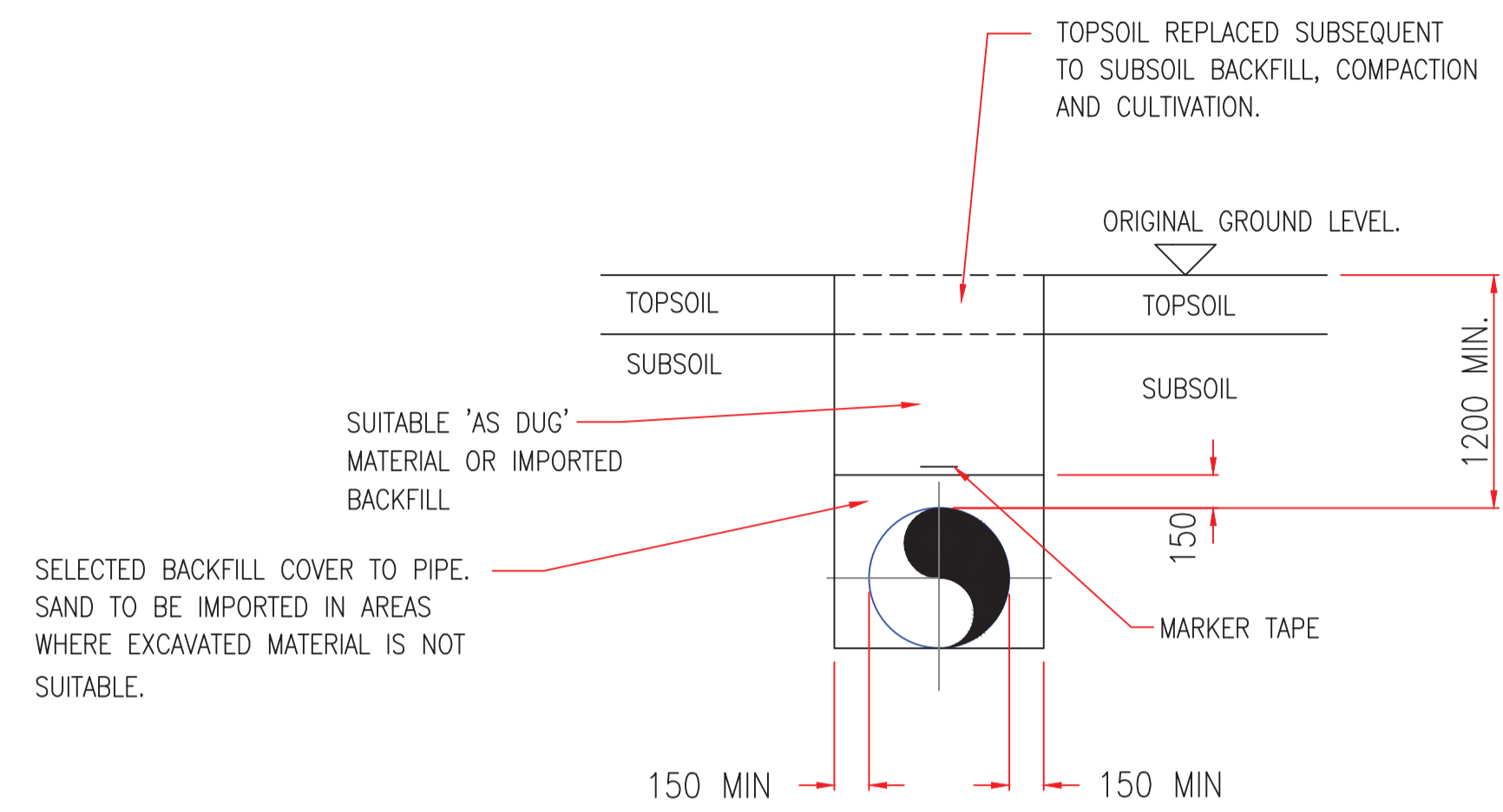

NORMAL INSTALLATION OF PIPELINE

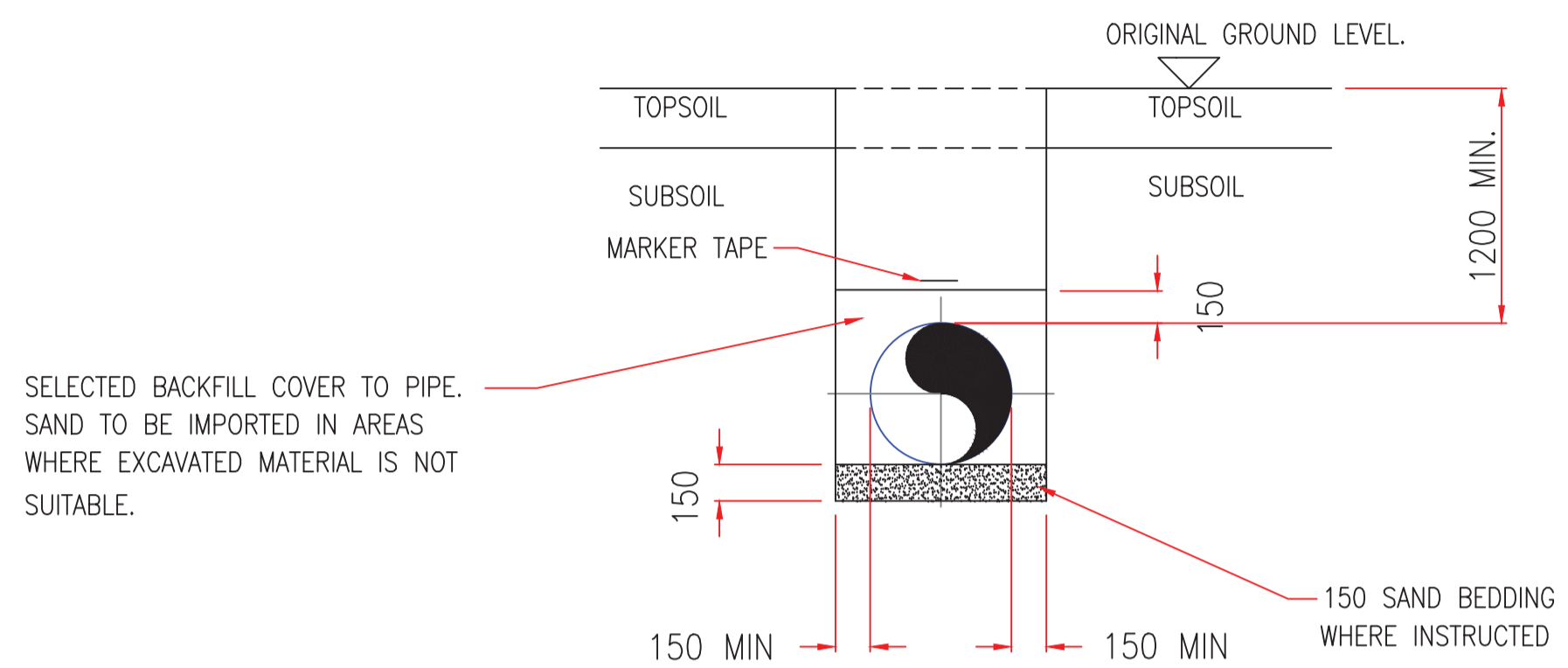

INSTALLATION OF PIPELINE WHERE BEDDING IS REQUIRED

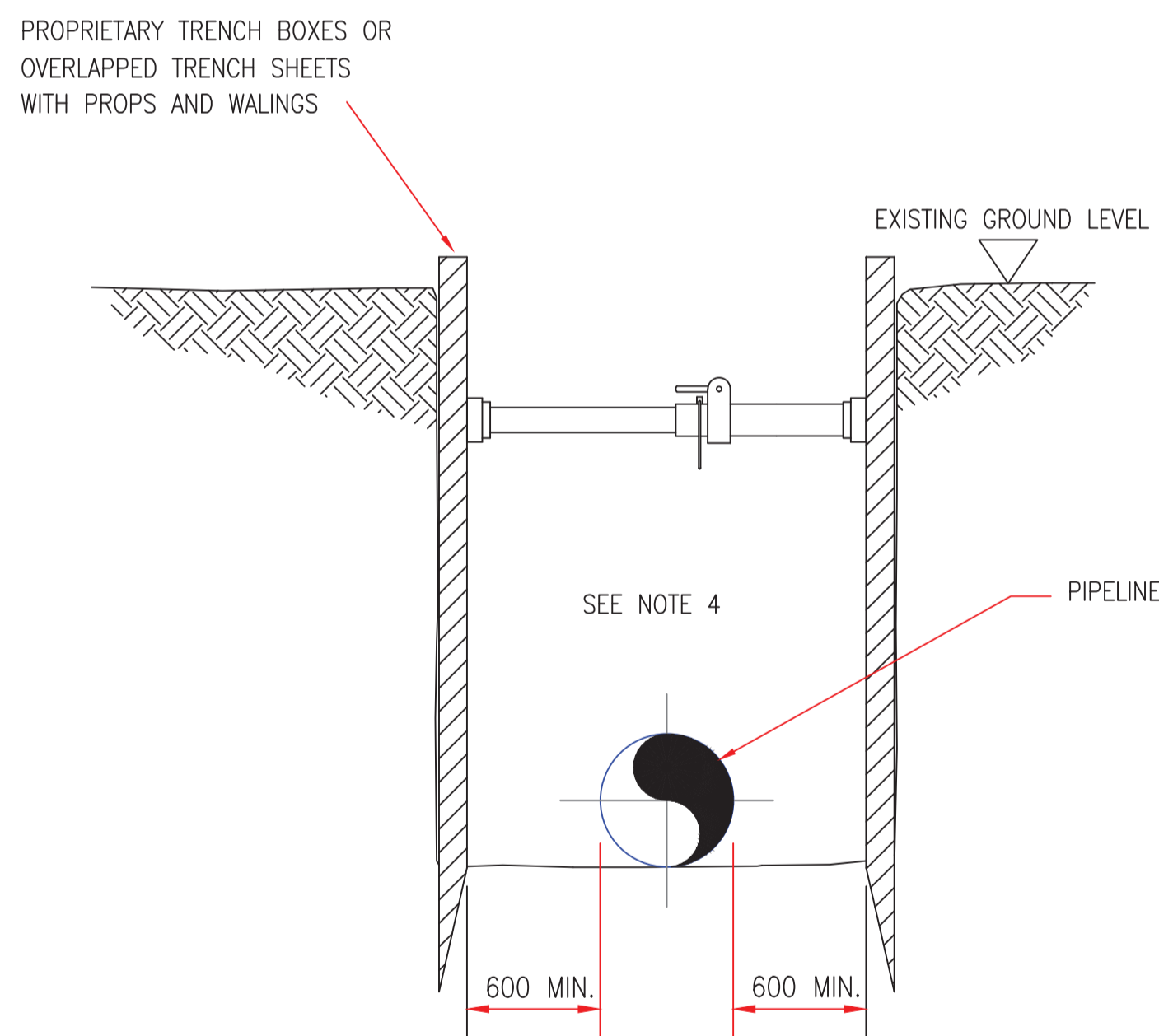

TYPE A

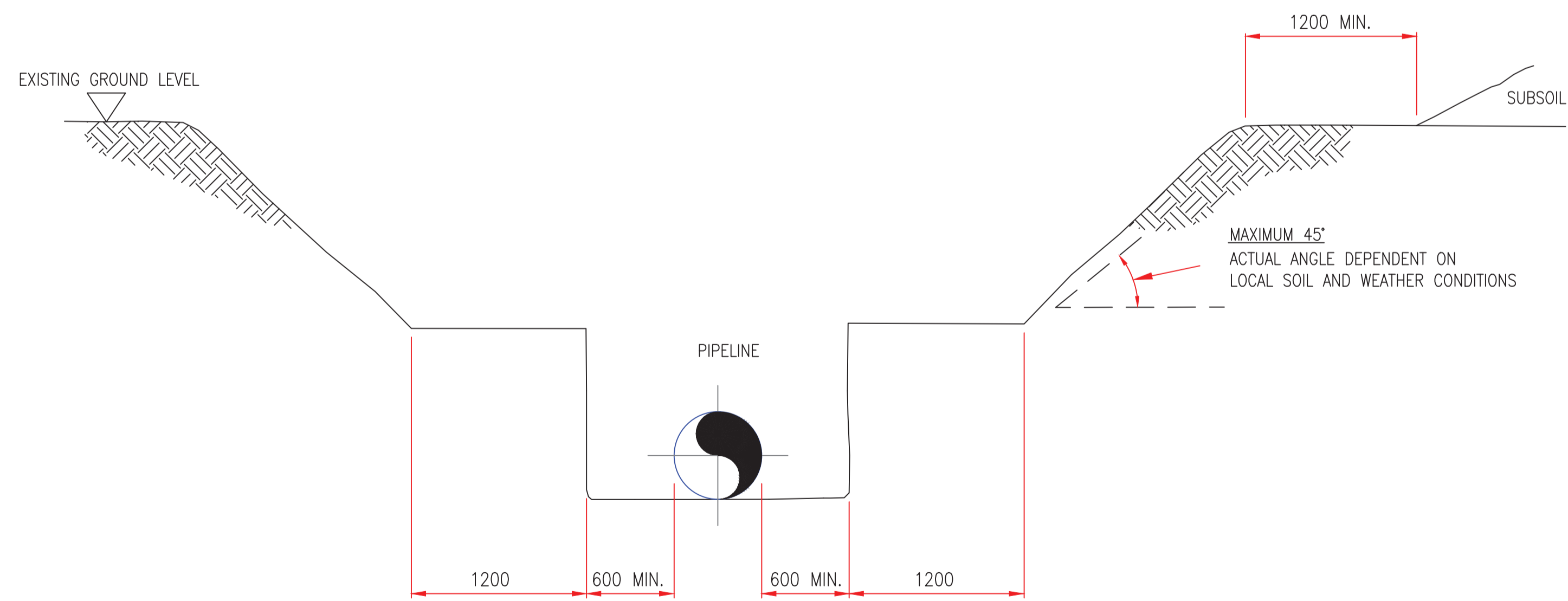

TYPE B

REQUIREMENT FOR TRENCH SUPPORT AND DETAIL WHERE MAN ENTRY IS REQUIRED

GENERAL NOTES

1. ALL DIMENSIONS ARE IN MILLIMETRES UNLESS OTHERWISE STATED.
2. THE GENERAL ARRANGEMENTS SHOWN ARE GIVEN AS EXAMPLES OF LAYOUTS. SHOULD ALTERNATIVE LAYOUTS BE PROPOSED, THE ACTUAL AREAS SHALL NOT EXCEED THE TOTAL AREAS SHOWN ON EACH SIDE OF THE CROSSING.
3. THE ADDITIONAL WORKING WIDTHS WILL BE NEGOTIATED WITH THE LANDOWNERS. SHOULD FURTHER WORKING AREAS BE REQUIRED, WRITTEN PROPOSALS SHALL BE OBTAINED FROM THE CLIENTS REPRESENTATIVE.
4. ADDITIONAL WORKING AREAS TO BE USED FOR CAR PARKING OR FOR TOP SOIL STORAGE AS DEEMED APPROPRIATE. HARD STANDING AREAS AND CAR PARKING AREAS TO BE APPROVED.

Rev	Rev. Date	Purpose of Revision	Drawn	Checked	Apprv'd
2	11/07/2023	ISSUED FOR INFORMATION	GS	GM	MH
1	05/06/2023	ISSUED FOR INFORMATION	DD	CC	MH
0	26/07/2022	ISSUED FOR REVIEW	DD	GK	NC

Penspen  
c/o Dar Al-Handasah  
150 Holborn  
London  
EC1N 2N2  
England, UK



Client  
Chrysaor Production (UK) Limited,  
23 Lower Belgrave Street,  
London  
SW1W 0NR



Project  
**VIKING CCS PIPELINE**

Drawing title  
**STANDARD DETAILS  
TRENCH EXCAVATION  
Regulation 5.2 (o)  
Application Document Reference 4.17  
(Sheet 1 of 1)**

Drawing status  
**ISSUED FOR INFORMATION**

Scale	NTS	DO NOT SCALE
Sheet Number	01 / 01	Original Sheet Size A1
Penspen Drawing Number	20428-PL-XTP-000-0002	Rev 2
Harbour Energy Drawing Number	PEN-GEN-P-XX-X-EN-51-00001	Rev D3

INFORMATION CONTAINED IN THIS DOCUMENT IS CONFIDENTIAL AND PROPRIETARY TO HARBOUR ENERGY OR ITS AFFILIATES. AFTER BEING PREPARED BY PENSPEN LIMITED OR ITS AFFILIATES AND IS FOR REFERENCE ONLY. HARBOUR ENERGY AND / OR PENSPEN DO NOT MAKE ANY REPRESENTATION OR WARRANTY AND SHALL NOT BE LIABLE IN ANY WAY WITH RESPECT TO THE INFORMATION CONTAINED HEREIN OR THE USE THEREOF. THE INFORMATION SHALL NOT BE REPRODUCED, COPIED, LOANED, LENT, RENTED, DISCLOSED OR USED IN WHOLE OR PART WITHOUT THE PRIOR WRITTEN CONSENT OF HARBOUR ENERGY OR PENSPEN. THE DOCUMENT AND ANY COPIES THEREOF SHALL BE RETURNED OR DESTROYED ON REQUEST OF HARBOUR ENERGY OR PENSPEN.