

Rampion 2 Wind Farm

Category 6:

Environmental Statement

Volume 2, Chapter 4: The Proposed Development

Date: August 2023

Revision A

Document Reference: 6.2.4
Pursuant to: APFP Regulation 5 (2) (a)
Ecodoc number: 004866026-01



Document revisions

Revision	Date	Status/reason for issue	Author	Checked by	Approved by
A	04/08/2023	Final for DCO Application	WSP	RED	RED

Contents

4.	The Proposed Development	7
4.1	Introduction	7
	Overview	7
	Rochdale Envelope	7
	The Rampion 2 design process	8
	Environmental measures	8
	Key components of the Proposed Development	9
	Key changes since the first statutory consultation exercise (2021)	10
	Structure of the chapter	15
4.2	Description of the Proposed Development	15
	The proposed DCO Order Limits	15
4.3	Offshore elements of the Proposed Development	16
	Introduction	16
	Wind turbine generators (WTG)	17
	WTG foundations	23
	Pre-construction surveys	23
	Seabed preparation	24
	Offshore substations	37
	Description of offshore cables	43
	Offshore cable installation	46
4.4	Export cable landfall	56
4.5	Onshore elements of the Proposed Development	60
	Overview	60
	Onshore cable corridor	60
	Onshore transformer substation	74
4.6	Onshore grid connection	77
	Introduction	77
	Description of Bolney substation extension options	78
	AIS extension option	78
	GIS extension option	79
	Installation	80
4.7	Construction programme	82
	Project programme	82
	Commissioning	83
	Construction timing	84
4.8	Operation and maintenance	85
	Introduction	85
	Offshore operation and maintenance	86
	Onshore operation and maintenance	94
4.9	Decommissioning	95

	Offshore decommissioning	95
	Onshore decommissioning	99
4.10	Consultation and engagement	100
	Responses to the Planning Inspectorate Scoping Opinion	100
	Statutory Consultation	112
4.11	Glossary of terms and abbreviations	115
4.12	References	123

List of Tables

Table 4-1	Proposed DCO Order Limits characteristics	16
Table 4-2	WTG maximum design assessment assumptions and parameters	19
Table 4-3	WTG oils and fluids	19
Table 4-4	Maximum vessel assessment assumptions and parameters for WTG installation	22
Table 4-5	Seabed preparation maximum assessment assumptions and parameters	25
Table 4-6	Maximum WTG monopile foundation assessment assumptions and parameters	30
Table 4-7	Maximum WTG multi-leg foundation with pin piles foundation assessment assumptions and parameters	32
Table 4-8	Maximum WTG multi-leg foundation with suction buckets foundation assessment assumptions and parameters	34
Table 4-9	Maximum vessel assessment assumptions for the WTG foundation installation and parameters	35
Table 4-10	Maximum offshore substation assessment assumptions and parameters – per substation	39
Table 4-11	Maximum offshore substation vessel installation assessment assumptions and parameters (for all three substations)	42
Table 4-12	Maximum array cable assessment assumptions and parameters	43
Table 4-13	Maximum offshore interconnector cable assessment assumptions and parameters	44
Table 4-14	Maximum export cable assessment assumptions and parameters	45
Table 4-15	Maximum array cable installation assessment assumptions and parameters	51
Table 4-16	Maximum offshore interconnector cable installation assessment assumptions and parameters	53
Table 4-17	Maximum export cable installation assessment assumptions and parameters	55
Table 4-18	Maximum export cable landfall assessment assumptions and parameters	59
Table 4-19	Maximum onshore cable corridor assessment assumptions and parameters	64
Table 4-20	Joint Bay, Link Box and Fibre Optic Cable Junction Box design assessment assumptions and parameters	66
Table 4-21	Maximum haul road assessment assumptions and parameters	70

Table 4-22	Construction compounds maximum assessment assumptions and parameters	71
Table 4-23	Maximum assessment assumptions and parameters for the onshore substation	75
Table 4-24	Maximum HGV and abnormal loads assessment assumptions and parameters for the substation	77
Table 4-25	Maximum assessment assumptions and parameters for the extension to Bolney NG substation	80
Table 4-26	Maximum assessment assumptions and parameters for operational and maintenance activities	87
Table 4-27	Maximum offshore vessels and logistics assessment assumptions and parameters for operation and maintenance	92
Table 4-28	The Planning Inspectorate's Scoping Opinion (2020) responses relevant to the description of the Proposed Development	100
Table 4-29	Glossary of terms and abbreviations	115

List of Graphics

Graphic 4-1	Key components of the Proposed Development	13
Graphic 4-2	Illustration of a WTG including maximum dimensions	18
Graphic 4-3	Example JUV installing a wind turbine (Rampion 1 offshore wind farm)	21
Graphic 4-4	Typical multicat utility vessel	22
Graphic 4-5	Monopile foundation schematic	29
Graphic 4-6	Multi-leg foundations with pin piles schematic	31
Graphic 4-7	Multi-leg foundations with suction buckets schematic	33
Graphic 4-8	Example JUV installing a WTG monopile foundation (Rampion 1 offshore wind farm)	37
Graphic 4-9	Example offshore substation with monopile foundation (London Array offshore wind farm)	38
Graphic 4-10	Example of offshore substation with four-legged multi-leg foundation (Rampion 1)	39
Graphic 4-11	Example offshore substation during installation (Rampion 1 offshore wind farm)	42
Graphic 4-12	Typical cross-sectional details through a three core high voltage export cable	45
Graphic 4-13	Example export cable installation vessel (Rampion 1 offshore wind farm)	47
Graphic 4-14	Typical marine cable installation plough	48
Graphic 4-15	Example array cable installation vessel (Rampion 1 offshore wind farm)	49
Graphic 4-16	Typical marine cable jetting seabed fluidiser	49
Graphic 4-17	Schematic of landfall crossing	57
Graphic 4-18	Example shallow draft barge	58
Graphic 4-19	Temporary construction corridor cross section	62
Graphic 4-20	Trench profile for hard/solid ground	63
Graphic 4-21	Trench profile for soil	63
Graphic 4-22	Illustration of a typical joint bay configuration	66

Graphic 4-23	Cross section of River Arun and the Chichester to Littlehampton railway line trenchless crossing	69
Graphic 4-24	Indicative construction programme	83
Graphic 4-25	Typical crew transfer vessel which can carry 12 to 16 passengers and equipment.	92

List of Figures, Volume 3

Document Reference

Figure 4.1	Offshore part of the proposed DCO Order Limits	6.3.4
Figure 4.2	Onshore part of the proposed DCO Order Limits	6.3.4
Figure 4.3a-u	Location of likely trenchless crossings	6.3.4
Figure 4.4a-c	Location of access points	6.3.4
Figure 4.5a-c	Proposed of temporary construction compound locations	6.3.4
Figure 4.6a-c	Onshore cable route kilometre points	6.3.4
Figure 4.7	Location of the National Grid Bolney substation extension	6.3.4
Figure 4.8	Location of the onshore substation at Oakendene	6.3.4

List of Appendices, Volume 4

Document Reference

Appendix 4.1	Crossings schedule	6.4.4.1
Appendix 4.2	Statutory consultation feedback	6.4.4.2
Appendix 4.3	Proposed Development Parameters	6.4.4.3

Executive Summary

Rampion Extension Development Limited (hereafter referred to as 'RED') (the Applicant) is developing the Rampion 2 Offshore Wind Farm Project (Rampion 2) located adjacent to the existing Rampion Offshore Wind Farm Project ('Rampion 1') in the English Channel.

Rampion 2 will be located between 13km and 26km from the Sussex Coast in the English Channel and the offshore array area will occupy an area of approximately 160km².

The key offshore elements of the Proposed Development will be as follows:

- up to 90 offshore wind turbine generators (WTGs) and associated foundations;
- blade tip of the WTGs will be up to 325m above Lowest Astronomical Tide (LAT) and will have a 22m minimum air gap above Mean High Water Springs (MHWS);
- inter-array cables connecting the WTGs to up to three offshore substations;
- up to two offshore interconnector export cables between the offshore substations;
- up to four offshore export cables each in its own trench, will be buried under the seabed within the final cable corridor; and
- the export cable circuits will be High Voltage Alternating Current (HVAC), with a voltage of up to 275kV.

The key onshore elements of the Proposed Development will be as follows:

- a single landfall site near Climping, Arun District, connecting offshore and onshore cables using Horizontal Directional Drilling (HDD) installation techniques;
- buried onshore cables in a single corridor for the maximum route length of up to 38.8km using:
 - ▶ trenching and backfilling installation techniques; and
 - ▶ trenchless and open cut crossings.
- a new onshore substation, proposed near Cowfold, Horsham District, which will connect to an extension to the existing National Grid Bolney substation, Mid Sussex, via buried onshore cables; and
- extension to and additional infrastructure at the existing National Grid Bolney substation, Mid Sussex District to connect Rampion 2 to the national grid electrical network.

Page intentionally blank

4. The Proposed Development

4.1 Introduction

Overview

- 4.1.1 Rampion Extension Development Limited (hereafter referred to as 'RED') (the Applicant) is developing the Rampion 2 Offshore Wind Farm Project (Rampion 2) located adjacent to the existing Rampion Offshore Wind Farm Project ('Rampion 1') in the English Channel.
- 4.1.2 Rampion 2 will be located between 13km and 26km from the Sussex Coast in the English Channel and the offshore array area will occupy an area of approximately 160km².
- 4.1.3 This chapter provides an overview of Rampion 2, hereafter referred to as the 'Proposed Development', and it sets out the main components of the offshore wind farm, associated substations and energy transmission infrastructure. It also describes the key activities that will be undertaken during the construction, operation and maintenance and decommissioning phases, and includes key assessment assumptions along with indicative timescales.

Rochdale Envelope

- 4.1.4 At this stage, the description of the Proposed Development is indicative and a 'design envelope' approach has been adopted which takes into account Planning Inspectorate Advice Note Nine: Rochdale Envelope, July 2018 (Planning Inspectorate, 2018). The provision of a design envelope is intended to identify key design assumptions to enable the environmental assessment to be carried out whilst retaining enough flexibility to accommodate further refinement during detailed design. Further details on the use of the Rochdale Envelope as recommended by the National Policy Statement (NPS) for Renewable Energy (EN-3) (Department of Energy and Climate Change (DECC), 2011 and the Draft National Policy Statement for Renewable Energy Infrastructure (EN-3), (Department for Energy Security and Net Zero (DESNZ), 2023) are provided in [Chapter 2: Policy and legislative context, Volume 2](#) of the ES (Document Reference 6.2.2).
- 4.1.5 Assessing the Proposed Development using this assumption-based design envelope approach means that the assessment will consider a maximum design scenario which allows flexibility to make design decisions in the future that cannot be finalised at the time of submission of the application for development consent. Such design decisions may include the precise models and dimensions of wind turbine generators (WTG) which will be available at the time of placing orders for the Proposed Development, final offshore WTG layout design to optimise wind energy capture, and detailed engineering factors for both the offshore and onshore infrastructure. The use of this approach has been adopted for this Environmental Statement (ES) and also enables the Environmental Impact Assessment (EIA) to

be based on a description of the location, design and size of the Proposed Development that is suitable to allow an assessment of its likely significant environmental effects.

- 4.1.6 The offshore and onshore parts of the proposed DCO Order Limits are illustrated in **Figure 4.1, Volume 3** (Document Reference 6.3.4) and **Figure 4.2, Volume 3** (Document Reference 6.3.4) respectively. The key offshore and onshore component assessment assumptions are provided in **Section 4.3** and **Section 4.5**. Where relevant, **bold** text indicates a parameter outlined in the DCO Application within assessment assumption tables **Table 4-2** to **Table 4-27**, a summary table for the parameters is also provided in **Appendix 4.3: Proposed Development Parameters, Volume 4** of the ES (Document Reference: 6.4.4.3).

The Rampion 2 design process

- 4.1.7 During the Rampion 2 design process, changes to the design have been made as more environmental and engineering information became available and in response to stakeholder feedback. **Chapter 3: Alternatives, Volume 2** of the ES (Document Reference 6.2.3) describes the reasonable alternatives that have been considered by Rampion Extension Development Limited (RED) to date, and the reasons why the proposed design has been chosen instead of the alternative locations and technologies. As described in **Chapter 5: Approach to the EIA, Volume 2** of the ES (Document Reference 6.2.5), where the design is still evolving, a precautionary approach is applied to ensure a maximum design scenario (MDS) which represents the worst-case scenario for each aspect is assessed in this ES. Each individual aspect Chapter, **Chapter 6: Coastal processes to 29: Climate change, Volume 2** of the ES (Document Reference: 6.2.6 to 6.2.29), provides commentary on the appropriate reasonable worst-case scenario adopted for the individual assessments.
- 4.1.8 The evolution of the design of the Proposed Development has taken account of consultation feedback received throughout the design process. This includes responses to the Planning Inspectorate's Scoping Opinion (Planning Inspectorate, 2020) and statutory consultation undertaken by RED as outlined in **Appendix 4.2: Statutory consultation feedback, Volume 4** of the ES (Document Reference 6.4.4.2).
- 4.1.9 A summary of all issues raised as part of the statutory consultation feedback and the project responses to them are provided in the **Consultation Report** (Document Reference: 5.1).

Environmental measures

- 4.1.10 As part of the Rampion 2 design process, a number of embedded environmental measures have been adopted to reduce the potential for environmental impacts and effects. These embedded environmental measures have evolved over the design development process and in response to consultation. They have fed iteratively into the EIA. As there is a commitment to implementing these environmental measures, and also to various standard sectoral practices and procedures, they are considered inherently part of the design of Rampion 2 and

are set out in this ES. The measures are presented in full in the **Commitments Register** (Document Reference: 7.22).

- 4.1.11 **Chapter 5: Approach to the EIA, Volume 2** of the ES (Document Reference 6.2.5) explains the approach to embedded environmental measures that has been applied in the ES. The environmental assessments presented in **Chapters 6: Coastal processes to 29: Climate change, Volume 2** of the ES (Document Reference: 6.2.6 to 6.2.29) provide details of how specific embedded environmental measures are proposed to avoid or reduce environmental effects.
- 4.1.12 RED will adopt good construction and management practices and will apply the waste hierarchy. This will ensure that waste arising during the construction, operation and maintenance, and decommissioning phases of the Proposed Development is minimised as far as possible and that the storage, transport and eventual disposal of waste have no significant environmental effects. The volume of waste produced in all phases of the Proposed Development is anticipated to be low and that it can be accommodated by local facilities. An **Outline Site Waste Management Plan** (Document Reference 7.3) has been prepared and submitted as part of the application for development consent.

Key components of the Proposed Development

- 4.1.13 The key offshore elements of the Proposed Development will be as follows:
1. up to 90 offshore wind turbine generators (WTGs) and associated foundations;
 - blade tip of the WTGs will be up to 325m above Lowest Astronomical Tide (LAT) and will have a 22m minimum air gap above Mean High Water Springs (MHWS);
 2. inter-array cables connecting the WTGs to up to three offshore substations;
 - up to two offshore interconnector export cables between the offshore substations;
 3. up to four offshore export cables each in its own trench, will be buried under the seabed within the final cable corridor; and
 - the export cable circuits will be High Voltage Alternating Current (HVAC), with a voltage of up to 275kV.
- 4.1.14 The key onshore elements of the Proposed Development will be as follows:
4. a single landfall site near Climping, Arun District, connecting offshore and onshore cables using Horizontal Directional Drilling (HDD) installation techniques;
 - buried onshore cables in a single corridor for the maximum route length of up to 38.8km using:
 - ▶ trenching and backfilling installation techniques; and
 - ▶ trenchless and open cut crossings.

- a new onshore substation, proposed near Cowfold, Horsham District, which will connect to an extension to the existing National Grid Bolney substation, Mid Sussex, via buried onshore cables; and
 - extension to and additional infrastructure at the existing National Grid Bolney substation, Mid Sussex District to connect Rampion 2 to the national grid electrical network.
- 4.1.15 For the purposes of the ES, the key components of the Proposed Development are separated into offshore and onshore elements and are presented in this Chapter separately. These key components are illustrated together in **Graphic 4-1**.
- 4.1.16 The export cable circuits will be High Voltage Alternating Current (HVAC), with a voltage of up to 275kV, no booster stations are required. Both High Voltage Direct Current (HVDC) and HVAC with a voltage of 400kV, were considered during the Rampion 2 design process. Due to the length of the export cables HVAC was chosen as the most economical means of connecting Rampion 2. A comparison of these options and the reasons for this choice are provided in **Chapter 3: Alternatives, Volume 2** of the ES (Document Reference 6.2.3).

Key changes since the first statutory consultation exercise (2021)

- 4.1.17 Since the original Preliminary Environmental Information Report (PEIR) (RED, 2021) was submitted in 2021 as part of the first Statutory Consultation exercise, the design of the Proposed Development has continued to evolve and be refined. Full details of the design changes are provided in **Chapter 3: Alternatives, Volume 2** of the ES (Document Reference 6.2.3). In summary, the project described in this chapter differs in the following ways from the original PEIR (RED, 2021) Chapter 4: The Proposed Development:
- the Offshore Array Area has been reduced in size and an area of WTGs to the west and south of Rampion 1 has been removed;
 - two wind farm separation zones, to the west and south of Rampion 1, were introduced to mitigate visual impacts by separating the Rampion 2 array area from the built Rampion 1 turbines. The area to the west of Rampion 1, is also designated as a Helicopter Refuge Area (HeRA), with the purpose of addressing the lines of sight (for search and rescue) and navigational safety concerns raised by the Marine and Coastguard Agency (MCA) during Statutory Consultation. The area to the south of Rampion 1, will also be compliant for use as a HeRA at 1nm width, but has not been designated solely for this purpose;
 - the spatial extent of the Rampion 2 Offshore Array Area has been reduced, which reduces the horizontal spread of turbines and increases the distance of Rampion 2 from the most sensitive areas of coastline (reducing the apparent height and visibility of turbines);
 - offshore substations will not be located on the perimeter of the array area, greatly reducing impacts on marine aggregate dredgers operating in the region;
 - the overall number of turbines has been reduced from a maximum of 116 to a maximum of 90;

- a single onshore substation site has been selected at Oakendene refined down from two onshore substation search areas presented in the original PEIR (RED, 2021);
- the onshore cable route has been refined to remove onshore cable route options and has been reduced in width from approximately 50m to 40m; and
- the inclusion of the extension works at the existing National Grid Bolney substation to connect Rampion 2 into the existing grid.

Page intentionally blank

Graphic 4-1 Key components of the Proposed Development

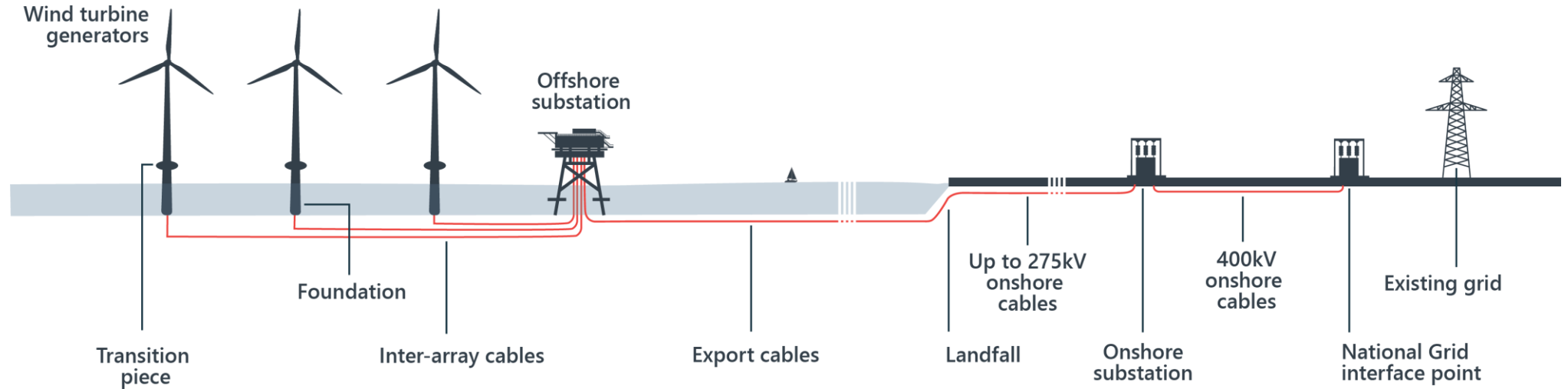

42885-WOOD-XX-XX-FG-O-0008_S2_P06.1.ai

Page intentionally blank

Structure of the chapter

4.1.18 The remainder of this chapter is structured as follows:

- **Section 4.2:** Description of the Proposed Development;
- **Section 4.3:** Offshore elements of the Proposed Development;
- **Section 4.4:** Export cable landfall
- **Section 4.5:** Onshore elements of the Proposed Development;
- **Section 4.6:** Onshore grid connection
- **Section 4.7:** Construction programme;
- **Section 4.8:** Operation and maintenance;
- **Section 4.9:** Decommissioning;
- **Section 4.10:** Consultation and engagement;
- **Section 4.11:** Glossary of terms and abbreviations; and
- **Section 4.12:** References.

4.2 Description of the Proposed Development

The proposed DCO Order Limits

- 4.2.1 The proposed Development Consent Order (DCO) Order Limits (illustrated in [Figure 1.1, Volume 3](#) (Document Reference 6.3.1)) used to inform this ES combines the offshore and onshore elements of the Proposed Development. It is defined as the area within which the Proposed Development and associated infrastructure will be located, including the temporary construction, and operation and maintenance work areas.
- 4.2.2 The offshore part of the proposed DCO Order Limits has been refined through multidisciplinary workshops, which took stakeholder feedback into account, and are further detailed in [Chapter 3: Alternatives, Volume 2](#) of the ES (Document Reference 6.2.3).
- 4.2.3 The Offshore Elements of the Proposed Development are situated within an area adjacent to the south and west of the existing Rampion 1 project site comprising seabed areas extending between 13km and 26km offshore (as shown on [Figure 4.1, Volume 3](#) (Document Reference: 6.3.4)). The offshore part of the proposed DCO Order Limits where development will be undertaken, comprises key components detailed in [paragraph 4.1.13](#). The offshore areas comprise the following:
- an Array area of approximately 160km², within which the WTGs, offshore substations, and associated foundations will be installed, with the exception of the wind farm separation areas set out in [paragraph 4.1.17](#), and an additional area of approximately 36km² to accommodate marine cables. No WTGs or offshore substations will be located within the marine cable area or within the

wind farm separation areas as shown on the **Offshore Works Plans** (Document Reference 2.2.1); and

- the Offshore Export Cable Corridor, which will connect the offshore wind farm area to the shore. Whilst part of the export cabling will be located within the Array area in order to connect to the offshore substations, these cables will ultimately be laid in an export cable corridor of 59km² between the edge of the array area and the landfall location. The nearest coastal settlements are Littlehampton, Worthing, Shoreham-by-Sea, Brighton, and Newhaven.

- 4.2.4 The onshore part of the proposed DCO Order Limits as illustrated on **Figure 4.2, Volume 3** (Document Reference 6.3.4) and presents the key components, as detailed in **paragraph 4.1.14**.
- 4.2.5 The onshore part of the proposed DCO Order Limits has been refined through multidisciplinary workshops, which took stakeholder feedback into account, including four statutory consultations (see **Section 4.10**). The onshore part of the proposed DCO Order Limits is illustrated in **Figure 4.2, Volume 3** (Document Reference 6.3.4)
- 4.2.6 The key characteristics of the proposed DCO Order Limits are summarised in **Table 4-1**.

Table 4-1 Proposed DCO Order Limits characteristics

Characteristic	Measurement
Wind farm array area for Rampion 2	196km ²
Export cable corridor	59km ²
Closest distance to shore of wind farm array area	13km
Water depth range in wind farm array area	15m to 65m below Lowest Astronomical Tide (LAT)
Onshore cable corridor length	Approximately 38.8km
Typical onshore cable corridor width	40m

4.3 Offshore elements of the Proposed Development

Introduction

- 4.3.1 The offshore elements of the Proposed Development refer to works seaward of Mean High Water Springs (MHWS) and will comprise the following key components:
- WTGs;
 - WTG foundations and any required scour protection;

- offshore substations and associated foundations and any required scour protection;
- inter-array cables and any required cable protection;
- interconnector cables to connect the offshore substations and any required cable protection; and
- export cables, and any required cable protection, to connect the offshore substations with the onshore export cables at the landfall.

4.3.2 The offshore part of the proposed DCO Order Limits is illustrated in **Figure 4.1, Volume 3** (Document Reference 6.3.4). The offshore components of the Proposed Development are assumed to mainly be fabricated off-site, stored at a suitable port facility and transported directly offshore as needed during construction. The key offshore component assessment assumptions are provided in the following sections. Where relevant, **bold** text indicates a parameter outlined in the DCO within assessment assumption tables (**Table 4-2 to Table 4-27**) and provided in **Appendix 4.3: Proposed Development Parameters, Volume 4** of the ES (Document Reference 6.4.4.3).

Wind turbine generators (WTG)

Design

- 4.3.3 The WTGs will comprise three turbine blades linked to a horizontal rotor axis and attached to a nacelle which houses a gearbox, generator, and transformer. This will be placed at the top of a tower which may be assembled in sections. The nacelle will be able to rotate or 'yaw' on the vertical axis in order to face the oncoming wind direction. The WTGs will include appropriate lighting and markers for aviation and navigation.
- 4.3.4 Inside the nacelle, the transformer will convert the electricity from approximately 690V to up to 132kV, for transmission to the offshore substations. The WTG transformer steps up generated electricity to a higher voltage to reduce losses during transmission over the longer distances to the offshore substation.
- 4.3.5 As WTG technology is continually evolving, it is difficult to definitively predict the generating capacity and size of WTG that will be commercially available at the point of procurement for construction. As such, the size and capacity of the WTGs for the Proposed Development will be determined during the final design stage prior to construction. The final turbine design will be selected in accordance with the parameters set out in the DCO. The maximum design scenario for the WTG is as follows, and as illustrated in **Graphic 4-2**.

Graphic 4-2 Illustration of a WTG including maximum dimensions

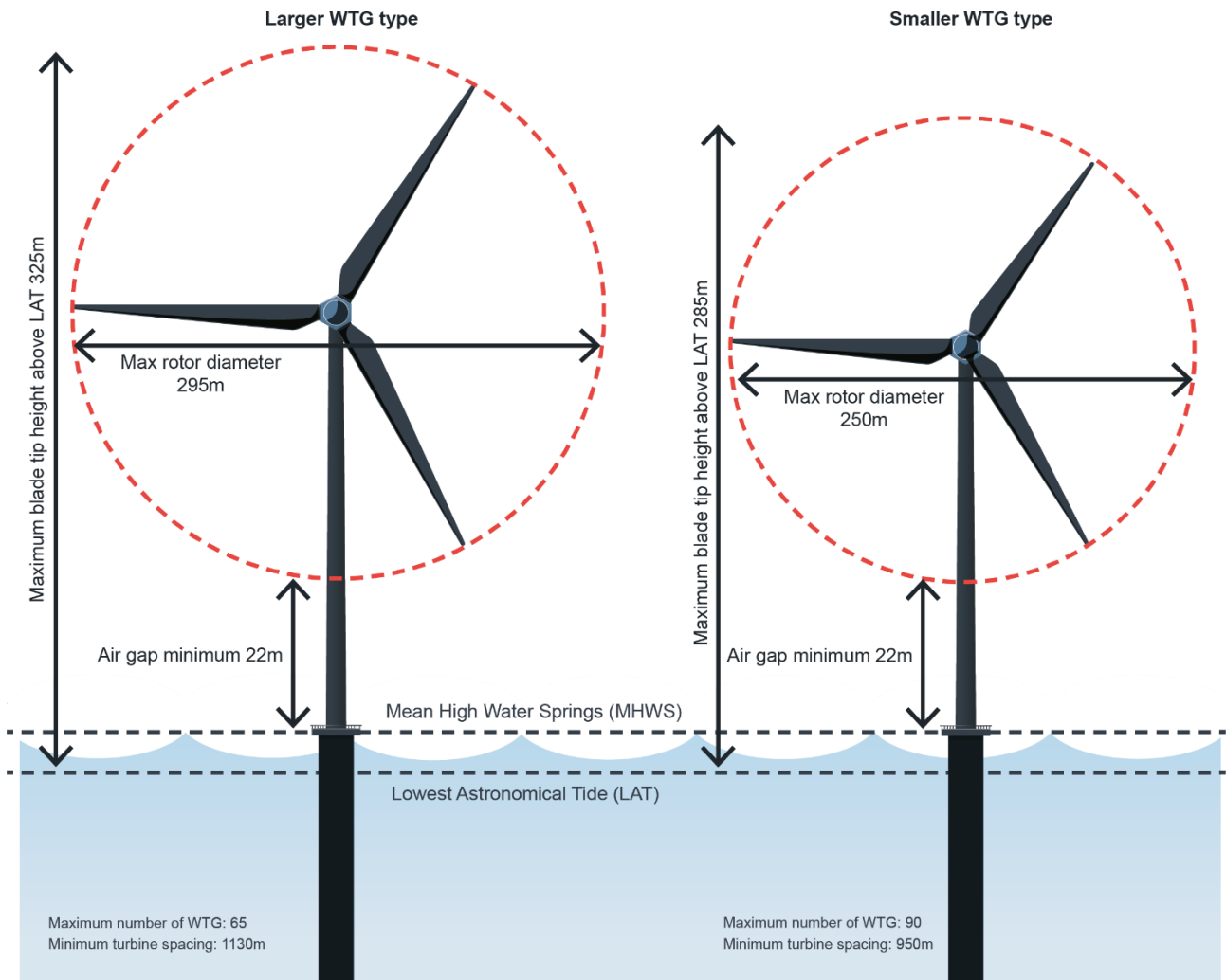

4.2_42285-WOOD-XX-XX-FG-O-0020_S2_P02.1.ai

4.3.6 As is common for all offshore wind farms, the final choice of WTG and therefore the final capacity of the Proposed Development will be subject to a procurement exercise carried out post-consent. This assessment therefore considers two WTG typologies based on the characteristics of turbine models which are expected to be available at that future stage. These are described throughout this ES as a “smaller WTG type” and “larger WTG type”, and the assessment considers two design scenarios based on up to 90 smaller WTG type turbines or 65 larger WTG type turbines. This is fewer than the 116 WTGs utilised for Rampion 1. The maximum rotor diameter and blade tip height quoted in **Table 4-2** for the larger WTG type will not be exceeded, regardless of the choice of WTG in the final Proposed Development. Other assessment assumptions derived from these scenarios are described in this chapter and the DCO/Deemed Marine Licence (DML) will ensure that these are not exceeded.

Table 4-2 WTG maximum design assessment assumptions and parameters

Assessment assumption or parameter	Smaller WTG Type	Larger WTG Type
	(Parameters presented in bold text)	
Maximum number of WTG	90	65
Rotor diameter	250m	295m
Minimum air gap above Mean High Water Springs (MHWS)	22m	22m
Maximum blade tip height above Lowest Astronomical Tide (LAT)	285m	325m
Maximum Chord (blade width)	9m	11m
Maximum RPM	7.6 RPM	5.9 RPM
Minimum to Maximum Blade pitch	-4 to 90 degrees	-4 to 90 degrees
Minimum turbine spacing	950m	1,130m

4.3.7 Minimum turbine spacing at 950m represents the minimum spacing for this scenario, however for the purposes of the EIA, and specified within the DCO, a minimum of 830m has been used to provide for the possibility of smaller WTGs being employed; note, other relevant assessment parameters of such a scenario would not exceed those presented here, importantly including the maximum of 90 WTGs.

4.3.8 Depending on the WTG, each is expected to contain the indicative maximum oil and fluid quantities outlined in **Table 4-3**.

Table 4-3 WTG oils and fluids

WTG oils and fluids	Smaller WTG Type	Larger WTG Type
Grease	838 litres (l)	1,137l
Hydraulic oil	1,583l	2,502l
Gear oil	3,108l	4,217l

WTG oils and fluids	Smaller WTG Type	Larger WTG Type
Total lubricants	5,528l	7,856l
Nitrogen	101,479l	113,905l
Transformer silicon/ester oil	11,358/kg	15,415l/kg
Diesel fuel	1,000l	1,000l
SF6	180kg	180kg
Glycol/Coolants	21,972l	29,819l

WTG control systems

4.3.9 WTGs operate within a set wind speed range:

- approximately 3m/s: the WTG will start to generate electricity;
- approximately 15m/s: the WTG reach maximum output; and
- approximately 25m/s: the WTG output starts to reduce towards zero allowing the WTG to shut down in high wind speeds.

4.3.10 Each WTG will have its own control system to carry out functions such as yaw control and ramp down in high wind speeds. The WTG must shut down in high winds to protect the WTG and foundation however the gradual reduction at 25m/s ensures a gradual ramp-down of the power output to support the operation of the National Grid.

4.3.11 All the WTG will be connected to a central Supervisory Control and Data Acquisition (SCADA) system for control of the wind farm remotely. This allows functions such as remote WTG shutdown if faults occur. The SCADA system will communicate with the wind farm via fibre optic cables, microwave, or satellite links. Individual WTGs can also be controlled manually from within the WTG nacelle or tower base in order to control the WTG for commissioning or maintenance activities.

WTG installation

4.3.12 The WTG towers, nacelles and blades will be transported from a port to the Proposed Development array area on the installation vessel or on a separate transport vessel. Further assessment of offshore traffic movements and port selection are covered in [Chapter 23: Transport, Volume 2](#) of the ES (Document Reference 6.2.23) and [Chapter 17: Socio-economics, Volume 2](#) of the ES (Document Reference 6.2.17). The WTG installation vessel is likely to be a jack-up vessel (JUV) with up to six legs, each taking up an area of 250m². The JUV can transport multiple WTG sets per trip. (**Graphic 4-3** and **Graphic 4-4**). The installation vessel will transit to the Rampion 2 array area and the components will be lifted onto the foundation substructure, by a crane situated on the installation vessel. Each WTG will be assembled on site with technicians fastening components together after they are lifted into place. The exact methodology for the

assembly is dependent on WTG type and installation contractor and will be defined in the pre-construction phase after grant of Development Consent.

Graphic 4-3 Example JUV installing a wind turbine (Rampion 1 offshore wind farm)



4.3.13 The total duration for WTG installation is expected to be around 12 months. **Section 4.7: Construction programme** provides further detail.

4.3.14 Vessels for WTG installation may require construction support vessels such as crew transfer vessels (CTV), tugs and multicat vessels. Multicat vessels are multifunctional all-purpose vessels, usually equipped with a winch and/or cranes on a flat deck (see **Graphic 4-4**).

Graphic 4-4 Typical multicat utility vessel



4.3.15 Further details on the maximum number of vessel trips for WTG installation are included in **Table 4-4**.

Table 4-4 Maximum vessel assessment assumptions and parameters for WTG installation

Assessment assumption or parameter	Smaller WTG Type	Larger WTG Type
	(Parameters presented in bold text)	
Jack-up area per leg	250m ²	250m ²
Jack-up number of legs	6	6
Installation vessel – maximum number of vessels	2	2
Installation vessel – total number of return trips	33	25
Support vessels – maximum number of vessels	10	10
Support vessels – total number of return trips	100	100
Crew transfer vessels – maximum number of vessels	10	10

Assessment assumption or parameter	Smaller WTG Type	Larger WTG Type
	(Parameters presented in bold text)	
Crew transfer vessels – total number of return trips	900	650
Helicopters – maximum number	2	2
Helicopters – total number of return trips	500	300
Construction vessel anchor footprint area	334,000m ² (based on the sum of export cable installation 73,772m ² ; WTG and offshore substation foundation installation 173,203m ² ; and topside installation 86,602m ²).	

WTG foundations

Introduction

4.3.16 The type of WTG foundation to be installed will be determined from the results of geotechnical investigations, existing environmental sensitivities and final WTG selection. It is anticipated that more than one type of foundation may be used across the Proposed Development. The results of preliminary engineering investigations indicate that several design options for the WTG foundations could be considered for the Proposed Development including:

- monopiles;
- multi-leg foundations with pin piles; and
- multi-leg foundations with suction buckets.

4.3.17 The foundations will be fabricated offsite, stored at a suitable port facility and transported to site as needed. Specialist installation vessels will be needed to transport and install foundations. The foundations will include access facilities and appropriate lighting and markers for aviation and navigation.

Pre-construction surveys

4.3.18 Geophysical and geotechnical surveys would be carried out before works commence and the information from those surveys would allow route debris, boulders, archaeological features, Unexploded Ordnance (UXO) presence, seabed features, sediment depth and the nature of the seabed to be determined. An analysis of these factors would then inform the final locations of WTGs (micrositing), the requirement for foundation drilling, cable routing design and installation methods, the target cable burial depth, and what (if any) additional

cable protection would be required. Micrositing is intended to provide flexibility to make minor adjustments to the project layouts to accommodate unexpected on-site conditions encountered in the pre-construction surveys.

Seabed preparation

- 4.3.19 Following the completion of all preconstruction activities, including satisfying pre-construction statutory consent conditions, engineering, design and procurement and detailed site surveys, seabed preparation is one of the first elements of the offshore construction process.
- 4.3.20 Requirements for seabed preparation will vary according to the specific ground conditions and the type of infrastructure being installed. Detailed geophysical surveys will be carried out preconstruction to provide further detail and to clarify the presence of boulders, unexploded ordnance (UXO) and other obstructions on the seabed.

UXO Clearance

- 4.3.21 Where UXO are identified, the initial process will be to undertake a risk assessment to determine the appropriate action (including avoidance, removal or in situ detonation). Recent advancements in the available methods for UXO clearance, mean that high-order detonation may be avoided. The methods of UXO clearance considered for the Proposed Development may include:
- High-order detonation;
 - Low-order detonation (deflagration);
 - Removal/ relocation; and
 - Other less intrusive means of neutralising the UXO.

Boulder clearance

- 4.3.22 Geophysical surveys will be undertaken within the Offshore Array Area and Offshore Export Cable Corridor and will be used to inform boulder clearance requirements.
- 4.3.23 Where large volumes of boulders are present, micrositing of cables around these would be onerous and impractical. If left in-situ, these boulders will pose the following risks:
- exposure of cables and/or shallow buried cables, that might lead to the requirement for post-lay cable protection such as rock placement;
 - obstruction risk to the cable installation equipment, leading to damage and/or multiple passes and therefore, a delayed cable installation programme (with no guarantee of achieving target burial depth); and
 - risk of damage to the cable assets.
- 4.3.24 Based on current industry experience the following assumptions are made:
- boulders greater than 0.3m in any dimension must be cleared;

- for cables within the Offshore Export Cable Corridor, a corridor of up to 25m per cable (circuit) must be cleared to ensure that all the export cable burial tools being considered can operate in the cleared corridors; and
- for any cables within the Offshore Array Area, a corridor of up to 25m must be cleared per cable circuit as this width is sufficient for the operation of the cable burial tools under consideration.

4.3.25 There are two key methods of clearing boulders, boulder plough and boulder grab. Where a high density of boulders is seen, the expectation is that a plough will be required to clear the cable installation corridor. Where medium and low densities of boulders are seen, a subsea grab is expected to be employed.

Pre-lay grapnel run

4.3.26 Following the pre-construction route survey and boulder clearance works, a Pre-Lay Grapnel Run (PLGR) and an associated route clearance survey of the final cable route will be undertaken. A vessel will be mobilised with a series of grapnels, chains, recovery winch and survey spread suitable for vessel positioning and data logging. Any items recorded will be recovered onto deck where possible and the results of this survey will be used to determine the need for any further clearance. The PLGR work will take account of and adhere to any archaeological protocols developed for the Proposed Development.

4.3.27 **Table 4-5** provides detail of the maximum assessment assumptions for the seabed preparation works for the Proposed Development. The table identifies the use of both a pre-lay plough and a subsea grab for boulder clearance. Pre-lay ploughs are designed to be pulled along the seabed in areas of high densities of boulders or where large boulders are present. They clear the corridor ready for cable installation and can also have the capability to concurrently form a cable trench. Sub-sea grabs are operated from vessels (e.g., multicat vessels) and are able to pick-up and relocate boulders in areas where low densities of boulders are present. Details of scour protection are provided in **Table 4-6**, **Table 4-7**, **Table 4-8** and **Table 4-10**.

4.3.28 Until the array layout is finalised, and the associated geophysical data is analysed in detail, it will not be known if sand waves will be affected by the works. Estimates are provided of sand wave clearance quantities for the maximum design scenario for assessment purposes.

Table 4-5 Seabed preparation maximum assessment assumptions and parameters

Assessment assumption or parameter	Maximum value (Parameters presented in bold text)
Unexploded Ordnance clearance	
Avoidance buffer: Foundation Exclusion Zone Radius (from each structure)	200m

Assessment assumption or parameter	Maximum value (Parameters presented in bold text)
Avoidance buffer: Cables (all offshore cables) Exclusion Zone Radius (from each cable)	40m
Avoidance buffer Jack-up leg Exclusion Zone Radius (from each structure)	15m
Boulder clearance in the Proposed Development array area	
Array area cable corridor (all cables) width: pre-lay plough	25m
Export interconnector cable clearance corridor width: pre-lay plough	25m
Clearance corridor width: subsea grab	15m
Clearance for foundations: radius	15m
Clearance for jack-up legs: radius	15m
Total clearance impact area: pre-lay plough for cables	8,800,000m ²
Total clearance impact area: subsea grab for cables	5,280,000m ²
Total clearance impact area: foundations and jack-up legs	1,313,000m ²
Boulder clearance in the Proposed Development offshore export cable corridor	
Clearance corridor width: pre-lay plough	25m
Clearance corridor width: subsea grab	15m
Total clearance impact area: pre-lay plough	1,700,000m ²
Total clearance impact area: subsea grab	1,020,000m ²
Sandwave clearance in the Proposed Development array area¹	

¹ Note: no sandwaves are expected on the export cable corridor.

Assessment assumption or parameter	Maximum value (Parameters presented in bold text)
Sandwave clearance impact width: array and interconnector cables	10m
Length of cables affected by sandwaves	60km
Sand-wave clearance: total in array area (export cables, array cables, interconnector cables and foundations)	1,375,000m ³

Scour protection

- 4.3.29 Scour protection material may be required around the base of some or all WTG foundations to protect from current and wave action ensuring structural integrity. Scour protection types currently being considered are rock or gravel placement, concrete mattresses, flow energy dissipation devices, or bagged solutions. Key scour protection assessment assumptions are provided in **Table 4-6**, **Table 4-7**, **Table 4-8** and **Table 4-10**.
- 4.3.30 An **Outline Scour Protection and Cable Protection Plan** (Document Reference 7.12) is submitted with the application for development consent, including details of the need, type, quantity and installation methods for scour protection. This will be updated post-consent as more information becomes available and will be agreed with the relevant stakeholders prior to construction.
- 4.3.31 Protection measures may be placed alone or in combination and may be secured to the seabed where appropriate. Typical options include one, or a combination of the following examples:
- Rock or gravel placement;
 - Concrete mattresses;
 - Flow energy dissipation devices (used to describe various solutions that dissipate flow energy and entrap sediment, and including options such as frond mats, mats of large, linked hoops, and structures covered with long spikes)²;
 - Protective aprons or coverings (solid structures of varying shapes, typically prefabricated in concrete or high-density plastics), and;
 - Bagged solutions, (including geotextile sand containers, rock-filled gabion bags or nets, and grout bags, filled with material sourced from the site or elsewhere).

² It is noted that these technologies are often only appropriate for use in areas with significant mobile seabed sediments, and examples such as the spiked designs are only appropriate for use in areas which are not trawled.

Safety Zones

- 4.3.32 During construction, safety zones of 500m radius will be sought around each WTG, offshore substation and their associated foundations structures whilst construction is undertaken, as clearly indicated by the presence of installation vessels. Several installation activities may take place simultaneously and consequently, safety zones will be sought to each of these activities as they take place within the offshore wind farm site. Prior to commissioning, a 50m radius safety zone will be sought around each constructed WTG, offshore substation and their associated foundations structures. Further information is set out within the Rampion 2 safety zone statement **Safety Zone Statement** (Document Reference: 5.6).

Monopile foundations

- 4.3.33 Monopile foundations are welded tubular steel foundations with a large diameter. Monopiles are installed vertically into the seabed by either driving (use of a pile-driving hammer), or a combination of driving and drilling techniques where harder ground conditions are present. Other appropriate alternative methods may be used as they become available and practicable.
- 4.3.34 The dimensions of the monopiles that may be used for the Proposed Development will depend on the size of the WTG, hydrodynamic forces, and ground conditions. It is estimated that the monopile diameter will be of 13.5m maximum with a maximum embedment depth of up to 60m. A tubular transition piece is bolted or grouted onto an installed monopile, and comprises the WTG tower flange, boat landings, work platforms and other ancillary structures. As an alternative, the WTG tower could be directly bolted to the monopile, with secondary structures such as boat landings, work platforms and other ancillary structures attached directly to either the WTG tower or the monopile. A typical monopile foundation schematic is provided in **Graphic 4-5**.

Graphic 4-5 Monopile foundation schematic

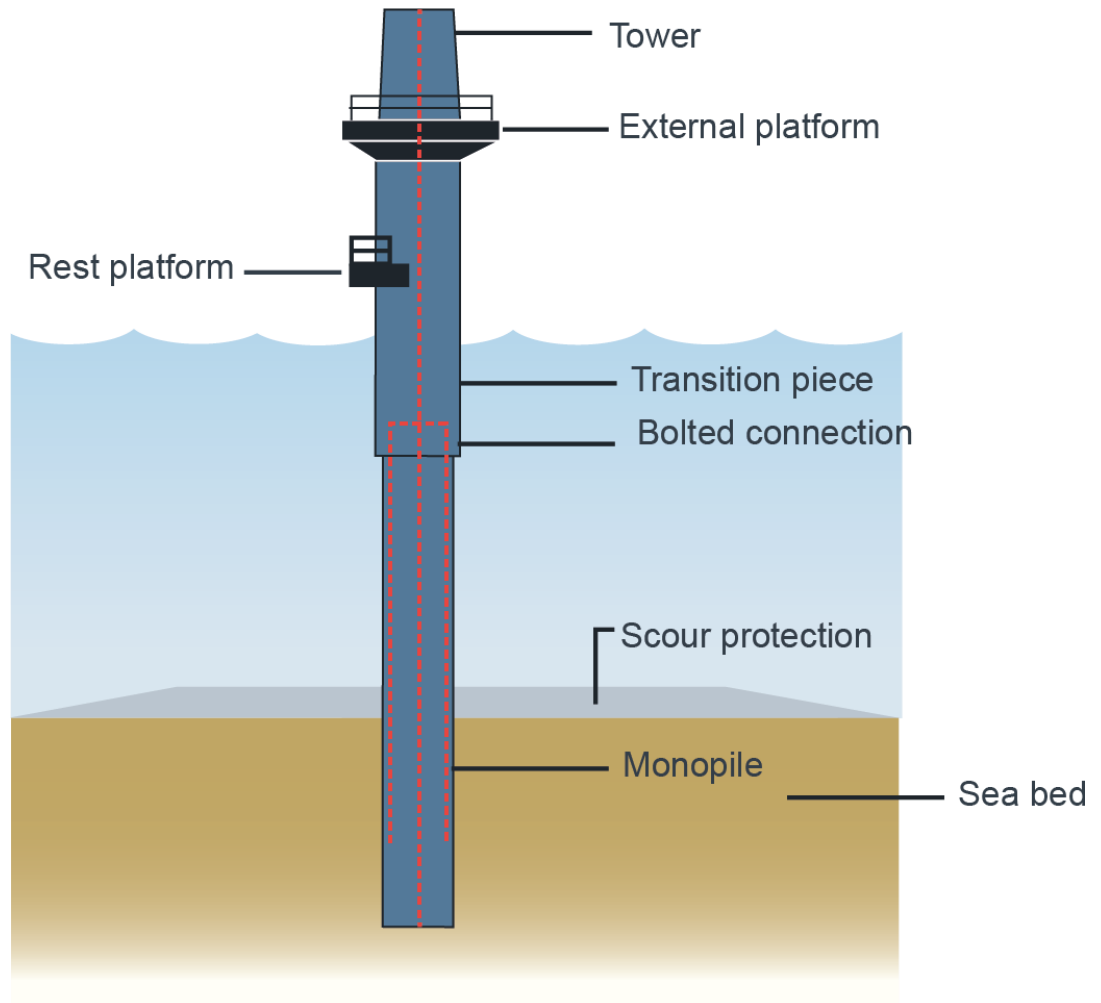

4.3.35 The monopile foundation assessment assumptions for the smaller and larger WTG types are provided in **Table 4-6**.

Table 4-6 Maximum WTG monopile foundation assessment assumptions and parameters

Monopile foundation assessment assumption or parameter	Smaller WTG Type	Larger WTG Type
(Parameters presented in bold text)		
Diameter of monopile	10m	13.5m
Diameter of transition piece	Up to 10m	Up to 13.5m
Typical embedment depth (below seabed)	30m to 60m	30 to 60m
Hammer energy	Up to 4,400kJ	Up to 4,400kJ
Total number of structures	Up to 90 WTGs	Up to 65 WTGs
Area of seabed take for foundation alone (per structure)	80m ²	143m ²
Scour protection type	Rock or gravel placement, Concrete mattresses, flow energy dissipation devices, or bagged solutions	Rock or gravel placement, Concrete mattresses, flow energy dissipation devices, or bagged solutions
Total area of seabed take for foundation and scour protection (per structure)	2,000m ²	3,580m ²
Spoil volume per foundation from drill arisings (per structure)	4,000m ³	7,200m ³
Jack-up spud can gravel bed volume (per structure)	4,000m ³	4,000m ³
Scour protection volume (per structure)	6,000m ³	10,500m ³
Monopile/ transition piece grout volume (per structure)	20m ³	25m ³

Multi-leg foundations with pin piles

4.3.36 Multi-leg foundations are typically lattice structures comprising of steel tubulars to support the WTG. The multi-leg foundation is secured to the seabed by small diameter pin piles which are driven into the seabed through pile sleeves at each leg. Alternatively, the pin piles may be pre-installed into the seabed through a template, prior to the arrival of the structure. The pin piles are connected to the multi-leg foundation legs via a grouted or deformed connection. Multi-leg foundations with up to four legs will be considered for the Proposed Development's WTGs. A typical multi-leg foundation with piles schematic is provided in **Graphic 4-6**.

Graphic 4-6 Multi-leg foundations with pin piles schematic

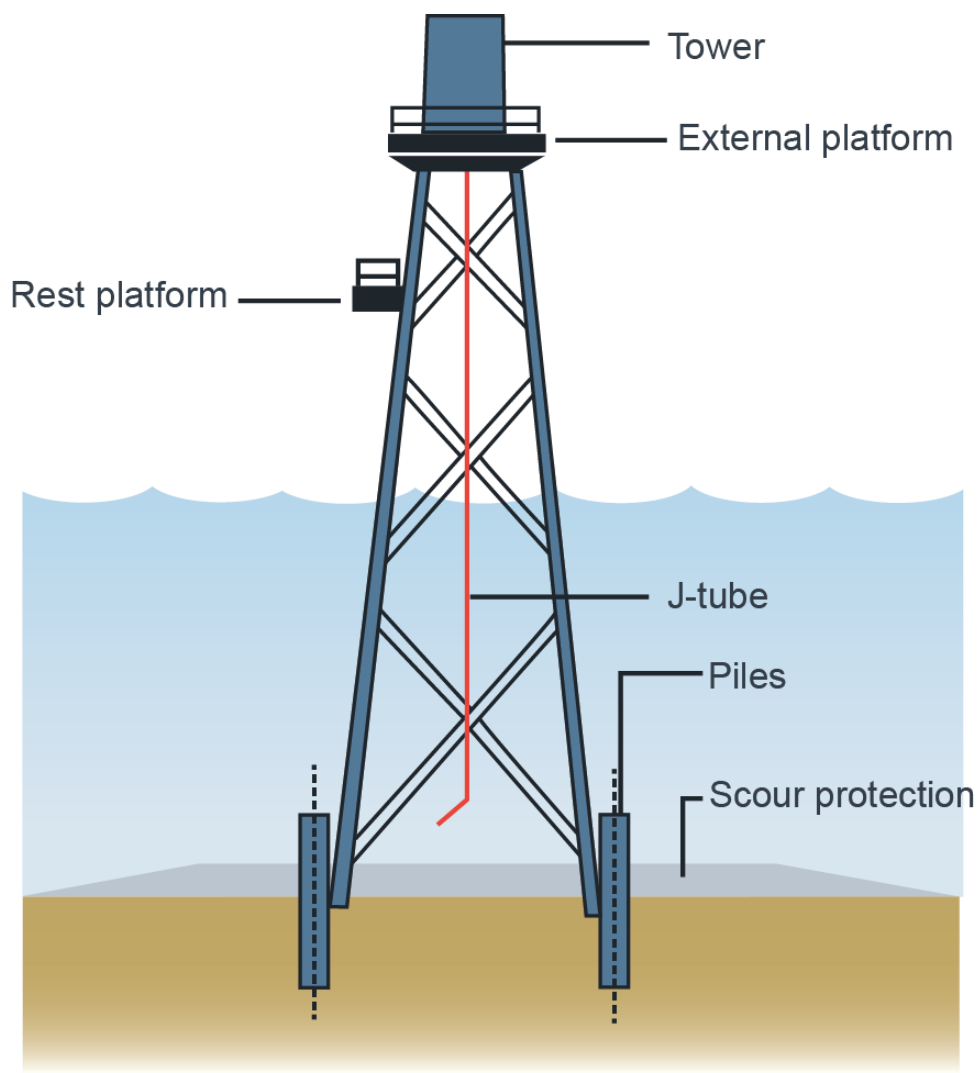

4.3.37 The multi-leg foundation with pin piles foundation assessment assumptions for the smaller and larger WTG types are provided in **Table 4-7**.

Table 4-7 Maximum WTG multi-leg foundation with pin piles foundation assessment assumptions and parameters

Multi-leg foundation with pin piles assessment assumption or parameter	Smaller WTG Type	Larger WTG Type
	(Parameters presented in bold text)	
Number of legs per multi-leg foundation	Up to 4	Up to 4
Separation of adjacent legs at seabed level	20m to 30m	Up to 45m
Separation of adjacent legs at LAT	10m to 20m	20m to 30m
Height of platform above LAT	15m to 25m	15m to 25m
Leg diameter	Up to 2.5m	Up to 5m
Number of pin piles per multi-leg foundation	Up to 4	Up to 4
Pin pile diameter	Up to 3.5m	Up to 4.5m
Embedment depth (below seabed)	Up to 60m	Up to 60m
Hammer energy	Up to 2,500kJ	Up to 2,500kJ
Spoil volume per foundation from pin pile drill arisings (per structure)	2,309m ³	3,817m ³
Scour protection type	Rock or gravel placement, Concrete mattresses, flow energy dissipation devices, or bagged solutions	Rock or gravel placement, Concrete mattresses, flow energy dissipation devices, or bagged solutions
Area of seabed take including scour protection (per structure)	2,500m ²	3,600m ²
Scour protection volume (per structure)	7,500m ³	10,800m ³

Multi-leg foundations with suction buckets

- 4.3.38 Suction buckets may be used as an alternative to pin piles for securing the multi-leg foundations to the seabed. Suction buckets comprise a large steel cylinder that is sealed at the top and, therefore, they do not require pile driving for installation. As a result, lower noise effects will be predicted to occur, compared to if a monopile or multi-leg foundations with pin pile foundations method of installation is utilised. The suction bucket is embedded into the seabed by creating a negative

(suction) pressure inside the bucket. The difference in pressure across the top plate as a result further pushes the bucket into the seabed. The Assessment assumptions for the multi-leg foundation with suction buckets, for the smaller and larger WTG types, are provided in **Table 4-8**.

4.3.39 A typical multi-leg foundation with suction buckets schematic is provided in **Graphic 4-7**.

Graphic 4-7 Multi-leg foundations with suction buckets schematic

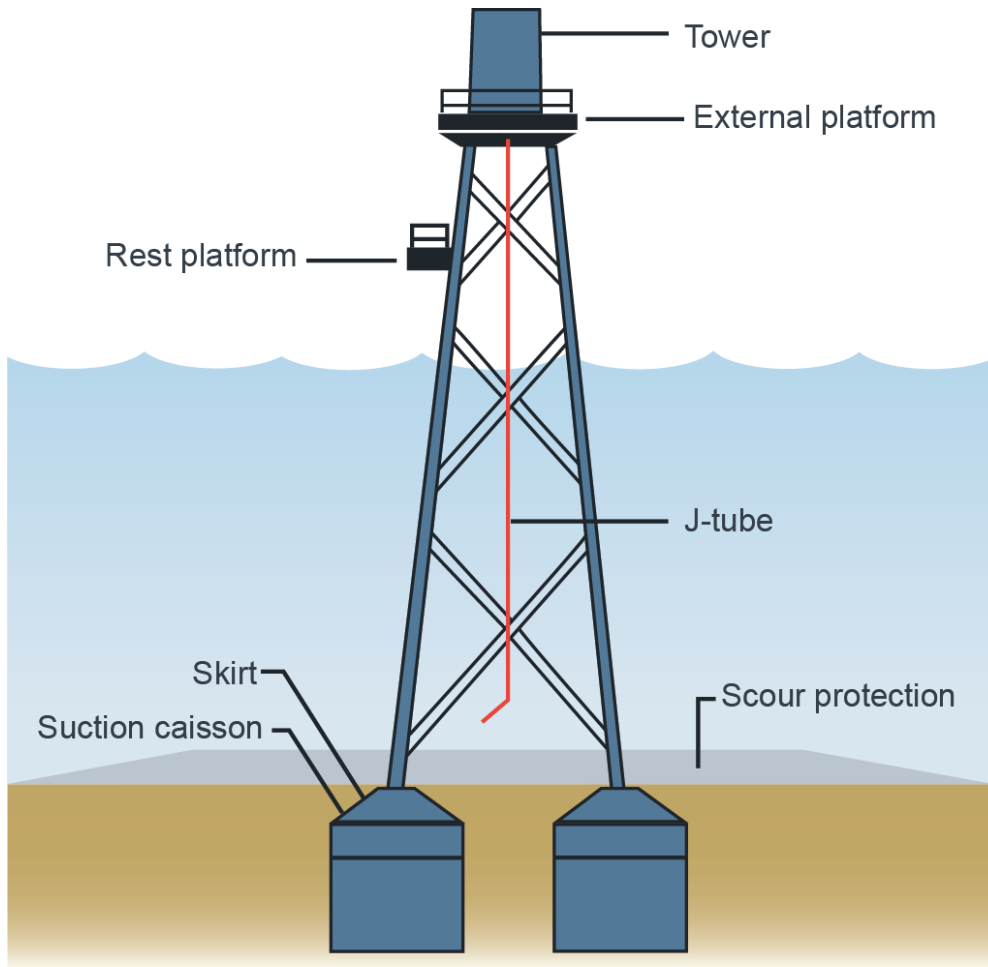

42285 - WOOD-XX-XX-FG-O-0021_S2_P02.1.ai

Table 4-8 Maximum WTG multi-leg foundation with suction buckets foundation assessment assumptions and parameters

Multi-leg foundation with suction buckets assessment assumption or parameter	Smaller WTG Type	Larger WTG Type
(Parameters presented in bold text)		
Number of legs per WTG	Up to 4	Up to 4
Suction bucket diameter	Up to 15m	Up to 15m
Suction bucket penetration	Up to 25m	Up to 25m
Suction bucket height above seabed	Up to 10m	Up to 10m
Separation of adjacent legs at seabed level	20m to 30m	20m to 40m
Separation of adjacent legs at LAT	10m to 20m	Up to 45m
Height of platform above LAT	15m to 25m	15m to 25m
Scour protection type	Rock or gravel placement, Concrete mattresses, flow energy dissipation devices, or bagged solutions	Rock or gravel placement, Concrete mattresses, flow energy dissipation devices, or bagged solutions
Area of seabed take including scour protection	4,500m ²	6,000m ²
Scour protection volume	13,500m ³	18,000m ³
Scour protection volume (WTG project total maximum)	1,215,000 m³	
Area of seabed take including scour protection (WTG project total maximum)	405,000 m²	

4.3.40 Vessel installation assessment assumptions for multi-leg foundation (with pin piles and suction buckets options) for the smaller and larger WTG types are provided in **Table 4-9**.

Table 4-9 Maximum vessel assessment assumptions for the WTG foundation installation and parameters

Assessment assumption or parameter	Maximum – monopiles	Maximum – multi-leg foundations with pin piles	Maximum – multi-leg foundations with suction buckets
(Parameters presented in bold text)			
Foundation for smaller WTG type			
Jack-up area per leg	250m ²	250m ²	250m ²
Jack-up number of legs	6	6	6
Number of installation vessels	3	3	3
Number of return trips (installation vessels)	60	50	50
Number of support vessels	10	10	10
Total number of return trips (support vessels)	60	50	50
Number of transport vessels	6	6	6
Total number of return trips (transport vessels)	60	50	45
Number of crew transfer vessels	6	6	6
Total number of return trips (crew transfer vessels)	500	400	400
Foundation for larger WTG type			
Jack-up area per leg	250m ²	250m ²	250m ²
Jack-up number of legs	6	6	6
Number of installation vessels	3	3	3

Assessment assumption or parameter	Maximum – monopiles	Maximum – multi-leg foundations with pin piles	Maximum – multi-leg foundations with suction buckets
(Parameters presented in bold text)			
Total number of return trips (installation vessels)	36	35	35
Number of support vessels	10	10	10
Total number of return trips (support vessels)	36	35	50
Number of transport vessels	4	4	4
Total number of return trips (transport vessels)	40	40	35
Number of crew transfer vessels	6	6	6
Total number of return trips (crew transfer vessels)	300	300	300

Graphic 4-8 Example JUV installing a WTG monopile foundation (Rampion 1 offshore wind farm)



Offshore substations

Introduction

- 4.3.41 It is anticipated that there will be up to three offshore substations associated with the Proposed Development. The offshore substations will transform generated electricity from the WTGs to a higher voltage for transmission to shore via export cables. The location and extent of the offshore substations will be confirmed through the detailed design process but will be located within the proposed DCO Order Limits.
- 4.3.42 It is anticipated that each offshore substation will likely comprise a multiple-tier topside platform installed on a foundation, typically a monopile or multi-leg foundation type foundation. The offshore substation platform will likely include components including transformers, batteries, generators, switchgear, fire systems, and modular facilities for operation and maintenance activities, similar to the offshore substation for Rampion 1. The offshore substations will include appropriate lighting and markers for aviation and navigation.
- 4.3.43 The offshore substation topside, with plan dimensions of up to 80m by 50m, will be situated at maximum 65m above LAT (excluding ancillary structures). The height of the lightning protection mast and ancillary structures (e.g. maintenance crane) is expected to be a maximum 115m above LAT.

4.3.44 The offshore substation foundation options being considered include monopile and multi-leg foundations (see **Graphic 4-9** and **Graphic 4-10**). **Table 4-10** provides the key parameters and assessment assumptions for the offshore substation.

Graphic 4-9 Example offshore substation with monopile foundation (London Array offshore wind farm)



Graphic 4-10 Example of offshore substation with four-legged multi-leg foundation (Rampion 1)



Table 4-10 Maximum offshore substation assessment assumptions and parameters – per substation

Assessment assumption or parameter	Maximum value (Parameters presented in bold text)
<i>Offshore substation</i>	
Maximum number of offshore substations	Up to 3
Topside: main structure length and width	80m x 50m
Topside: height (excluding helideck or lightning protection) †	65m above LAT
Height of lightning protection & ancillary structures	115m above LAT
Topside: Plan area	4,000m²
Topside (including ancillaries) Plan area	4,000m²
Transformer oil	340,000kg
Diesel Fuel	20,000l

Assessment assumption or parameter	Maximum value (Parameters presented in bold text)
SF6	5,000kg
Batteries (lead acid gel)	4,000kg
Grey water	5,000l
Black water	3,000l
Total surface area of introduced hard substrate from foundations in the water column	42m ² per m of water depth (total surface area of subsea portions of foundations in contact with the water column)
<i>Monopile foundations</i>	
Diameter of monopile	13.5m
Total number of substation structures	Up to 3
Hammer energy	4,400kJ
Seabed take of foundation alone	143m ²
Scour protection type	Rock or gravel placement, concrete mattresses, flow energy dissipation devices, or bagged solutions
Area of seabed take including scour protection	3,580m ²
Spoil volume	8,600m ³
Jack-up spud can gravel bed volume	4,000m ³
Scour protection volume	10,500m ³
Pile-structure grout volume	43m ³
<i>Multi-leg foundation with pin piles foundations</i>	
Total number of substation structures	Up to 3
Number of legs per multi-leg foundation (Substation)	Up to 6
Number of pin piles per multi-leg foundation (Substation)	Up to 12
Pin pile diameter	Up to 4.5m

Assessment assumption or parameter	Maximum value (Parameters presented in bold text)
Separation of adjacent legs at seabed level	20m to 50m
Separation of adjacent legs at LAT	20m to 40m
Height of multi-leg foundation above LAT	15m to 25m
Leg diameter	Up to 5m
Embedment depth below seabed	Up to 60m
Hammer energy	Up to 2,500kJ
Seabed take of foundation alone	2,475m ²
Scour protection type	Rock filter and armour layer or rock/stone filled geotextile bags
Area of seabed take including scour protection	7,300m ²
Spoil volume	12,000m ²
Jack-up spud can gravel bed volume	4,000m ³
Scour protection volume	21,900m ³
Scour protection volume (3 substations)	65,700m³
Pile-structure grout volume	360m ³

Offshore substation installation

- 4.3.45 The offshore substation foundations will be transported offshore using a JUV or transportation barge. The foundations will then be installed using a similar approach to the WTG foundations (see **paragraph 4.3.37**).
- 4.3.46 The majority of the electrical equipment and associated components will be installed into the offshore substation topsides at a fabrication facility onshore. The assembled topsides will be transported from a port or harbour local to the fabrication facility to the Proposed Development array area using a transportation barge. The offshore substation topsides will be lifted off the barge and installed onto its pre-installed foundations using a floating crane vessel or JUV. A JUV may be stationed alongside the offshore substation structure to facilitate commissioning activities (see **Graphic 4-11**). Helicopters may also be used to transport technicians at the offshore substations during commissioning.

Graphic 4-11 Example offshore substation during installation (Rampion 1 offshore wind farm)



4.3.47 The vessel assessment assumptions for the installation of the offshore substation are provided in **Table 4-11**.

Table 4-11 Maximum offshore substation vessel installation assessment assumptions and parameters (for all three substations)

Assessment assumption or parameter	Maximum value (Parameters presented in bold text)
Number of installation vessels	3
Number of total return trips (installation vessels)	12
Jack-up area per leg	250m ²
Jack-up number of legs	6
Number of support vessels	20
Number of total return trips (support vessels)	12
Number of transport vessels	6

Assessment assumption or parameter	Maximum value (Parameters presented in bold text)
Number of total return trips (transport vessels)	12
Number of crew transfer vessels	6
Number of total return trips (crew transfer vessels)	180
Number of vessels for commissioning Special Operation Vessels (SOV) or jack-up	2
Number of total return trips (for commissioning SOV or jack-up)	12
Number of helicopters	2
Number of total return trips (helicopters)	30

Description of offshore cables

Array cables

4.3.48 Subsea array cables will connect the WTGs to each other in strings. The array cable strings will connect the WTGs to the offshore substations. The array cable profile will likely be a three core, armoured cable with copper or aluminium conductors covered in insulation material. The array cables will also contain fibre-optic cores that will be used for protection, control, and communications systems. The array cables will be up to 132kV and the length of cable will be dependent on the distance between the WTG. The total maximum array cable length is expected to be 250km. **Table 4-12** presents the key assessment assumptions for the array cables.

Table 4-12 Maximum array cable assessment assumptions and parameters

Assessment assumption or parameter	Maximum value (Parameters presented in bold text)
Total array cable length	250km
Array cable burial depth	1m target depth
Cable diameter	Up to 350mm
Cable trench width	2m
Voltage	Up to 132kV

Interconnector export cables

- 4.3.49 The Proposed Development may use two offshore interconnector cables to link together the offshore substations in the array area. These interconnector cables also ensure that in the event of one cable failing, the flow of electricity can continue through the other cable(s).
- 4.3.50 The interconnector cables are likely to be armoured and have three core cables with copper or aluminium conductors and cross-linked polyethylene (XLPE) insulation, with a voltage up to 275kV. The interconnector cables will also contain fibre-optic cores that will be used for protection, control, and communications systems. **Table 4-13** provides the assessment assumptions for the offshore interconnector cables.

Table 4-13 Maximum offshore interconnector cable assessment assumptions and parameters

Assessment assumption or parameter	Maximum value (Parameters presented in bold text)
Number of cables	2
Total cable length	40km
Array cable burial depth	1m target depth
Cable diameter	Up to 350mm
Interconnector cable trench width	2m
Voltage	up to 275kV

Export cables

- 4.3.51 The main export cables will connect the offshore substations to the shore. They are likely to be armoured and have three core cables with copper or aluminium conductors and XLPE insulation, at a voltage up to 275kV. The cross-section of a typical XLPE insulated three copper core export cable is shown in **Graphic 4-12**. The export cables will also contain fibre-optic cores that will be used for protection, control, and communications systems.

Graphic 4-12 Typical cross-sectional details through a three core high voltage export cable

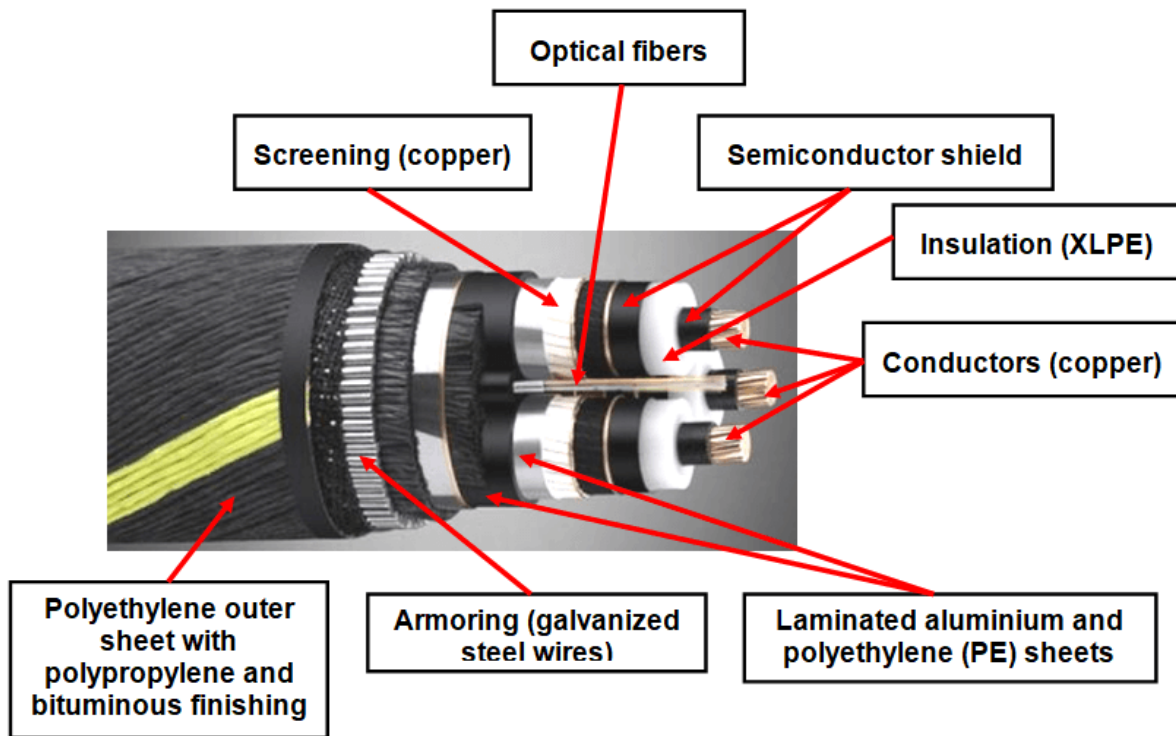

- 4.3.52 Electricity from the offshore substation(s) will be transmitted via a maximum of four export cables to the transition joint bays located at the landfall near Climping Beach, West Sussex. It is anticipated the export cables will be laid in separate trenches at different times and installed via either ploughing, jetting, trenching, or post-lay burial techniques. The choice of technique will be dependent on ground conditions along the specific export cable routes.
- 4.3.53 The export cables will be typically buried at a target burial depth of 1.0 to 1.5m below the seabed surface depending on the outcome of the cable burial risk assessment. The exact routing of the export cables within the offshore cable corridor will be determined during the detailed design of the Proposed Development, with consideration of seabed conditions and environmental sensitivities, following pre-commencement surveys. There are no known third-party cables within the offshore export cable corridor for the Proposed Development. **Table 4-14** provides the assessment assumptions for the offshore export cables.

Table 4-14 Maximum export cable assessment assumptions and parameters

Assessment assumption or parameter	Maximum value (Parameters presented in bold text)
Export cable	
Export cable rated capacity	Up to 275kV

Assessment assumption or parameter	Maximum value (Parameters presented in bold text)
Number of high voltage alternating current (HVAC) offshore cables	4
Export cable trenches	Up to 4
Fibre optic cables	Bundled into export cable
Export cable trench depth	1.0m to 1.5m
Export cable trench width	2m
Export cable corridor	59km ²
Number of cable circuits (HVAC)	4
Cable diameter	Up to 350mm
<i>Export cable corridor</i>	
Length of offshore cable corridor, link to shore	17km
Width of offshore cable corridor, link to shore	1.5km
Total length of export cables	170km

Offshore cable installation

Overview

- 4.3.54 Cables will be buried below the seabed, to a target burial depth of 1 -1.5m, wherever possible. The installation method and target burial depth will be defined post consent based on a cable burial risk assessment considering ground conditions as well as the potential for impacts upon cables such as from trawling and vessel anchors.
- 4.3.55 It is anticipated that the offshore cables will be installed via either ploughing, jetting, trenching, or a combination of these techniques, depending on ground conditions along the specific cable route, following the relevant seabed preparation outlined from **paragraph 4.3.19**. An example cable installation vessel is shown in **Graphic 4-13**.

Graphic 4-13 Example export cable installation vessel (Rampion 1 offshore wind farm)



Ploughing

- 4.3.56 This method involves a blade, which cuts through the seabed and the cable is laid behind. Ploughs are generally pulled directly by a surface vessel or they can be mounted onto a self-propelled tracked vehicle which runs along the seabed. Cable ploughs are usually deployed in simultaneous 'lay and trench' mode although it is possible to use the plough to cut a trench for the cable to be installed at a later date provided the ground conditions are suitable. When installing the cable in simultaneous lay and trench operation the plough may use cable depressors to push the cable into position at the base of the cut trench; as the plough proceeds the trench is backfilled to provide immediate burial.
- 4.3.57 Ploughs can be used in seabed geology ranging from very soft mud through to firm clays but, in general, ploughs are not suited to harder substrates such as boulder clay. Some ploughs are fitted with water jet assist options and/or hydraulic chain cutters to work through patches of harder soils. A typical plough design is shown in **Graphic 4-14**.

Graphic 4-14 Typical marine cable installation plough



Jetting

- 4.3.58 This method involves directing water jets towards the seabed to fluidise and displace the seabed sediment. This forms a typically rectangular trench into which the cable generally settles under its own weight.
- 4.3.59 The water jets are usually deployed on jetting arms beneath a remotely operated vehicle (ROV) system that can be free-swimming or based on passive skids or active tracks. There are also towed jetting skids available for the installation of cables.
- 4.3.60 During the formation of the trench the displaced sediment is forced into suspension and settles out at a rate determined by the sediment particle size, density and ambient flow conditions. The jetting process is not intended to displace sediment to an extent that it is totally removed out of the trench; moreover, it requires that the fluidised sediment is available to fall back into the trench for immediate burial through settling. It is only the finer fractions of sediments that are likely to be held in suspension long enough to become prone to dispersal away from the trench as a plume.
- 4.3.61 A key benefit of a jetting tool is that it can operate close to structures and it is also possible to use jetting tools for remedial burial if required. Typically, there are two methods of water jetting available: ‘Seabed Fluidisation’ and ‘Forward Jetting a Trench’. Typical requirements for remedial burial are described in **paragraph 4.8.12**.
- 4.3.62 Seabed Fluidisation involves first laying the cable on the seabed and afterwards positioning a jetting sledge above the cable. Jets on the sledge flush water beneath the cable fluidising the soil whereby the cable, by its own weight, sinks to the depth set by the operator.
- 4.3.63 Forward Jetting a Trench uses water jets to jet out a trench ahead of cable lay. The cable can typically be laid into the trench behind the jetting lance. An example of the vessel and equipment used to jet cables into the seabed is shown in **Graphic 4-15** and **Graphic 4-16**.

Graphic 4-15 Example array cable installation vessel (Rampion 1 offshore wind farm)



Graphic 4-16 Typical marine cable jetting seabed fluidiser



Trenching

- 4.3.64 Trenching involves the excavation of a trench whilst temporarily placing the excavated sediment adjacent to the trench. The cable is then laid, and the displaced sediment used to back-fill the trench, covering the cable. This is most commonly used where the cable must be installed through an area of rock or seabed composed of a more resistant material. Trenching is a difficult, time-

consuming and expensive method to use compared to other methods and will only be used in exceptional circumstances.

Cable protection

- 4.3.65 There is likely to be a requirement for cable protection to be installed around the inter-array cables as they transition from the seabed to enter the WTG via internal or external J-tubes or I-tubes (hollow tubes hung from the foundation that are in the shape of an “J” or “I”). The exact amount of cable protection required on each cable end will depend on the burial depths achieved by the inter-array cable installation and assessment of the scour and movement that could occur during the operating life of the offshore wind farm.
- 4.3.66 Cable protection will also be required where cable burial depth is not achieved or possible due to ground conditions and at third party cable crossings which may occur on the cable routes. It is estimated that approximately 20% of the array cable may require protection measures.
- 4.3.67 Following a judicial review challenging the Secretary of State’s decision not to grant development consent to AQUIND in February 2023, the decision was quashed and is now being redetermined. If approved and built, the AQUIND interconnector cable is proposed to cross the western part of the proposed DCO Order Limits. In the eventuality that cable crossings are required for this cable or any other potentially unknown subsea cables / pipelines, then a methodology will be agreed in collaboration with the relevant infrastructure owners.
- 4.3.68 The exact form of cable protection used will depend upon local ground conditions, hydrodynamic processes and the selected cable protection contractor. However, the final choice will include one or more of the following:
- concrete ‘mattresses’;
 - rock placement;
 - geotextile bags filled with stone, rock or gravel;
 - polyethylene or steel pipe half shells, or sheathes; and / or
 - bags of grout, concrete, or another substance that cures hard over time.
- 4.3.69 If rock placement, or filled bags are used to protect cables, they are typically used to construct a berm on the seabed on top of the cable. The rock placement method of cable protection involves placing rocks of different grade sizes from a fall pipe vessel over the cable. Initially smaller stones are placed over the cable as a covering layer. This provides protection from any impact from larger grade size rocks, which are then placed on top. The rock berm will be up to 1m in height and a maximum of 6m wide.

Installation of array cables

- 4.3.70 The array cables will typically be buried at a target burial depth of 1m below the seabed surface depending on the outcome of the cable burial risk assessment. The final depth of the cables will be dependent on the seabed geological conditions and the risks to the cable (for example from anchor drag damage).

Cable installation may require some form of seabed preparation which may include a Pre-Lay plough, boulder relocation and possibly sandwave clearance.

- 4.3.71 The array cables will be manufactured at a specialist supplier's factory. The manufactured cables will be spooled from the factory onto cable carousels situated on a transport vessel or directly onto the installation vessel itself, moored at an adjacent quayside. If a transport vessel is used, the cables will be subsequently transpoiled onto the installation vessel at a local port before it transits to the Proposed Development site for installation.
- 4.3.72 It is anticipated that the installation of the array cables will take place over two spring / summer seasons of up to six months each. **Table 4-15** presents the key assessment assumptions for the array cable installation.

Table 4-15 Maximum array cable installation assessment assumptions and parameters

Assessment assumption or parameter	Maximum value (Parameters presented in bold text)
<i>Array cable installation</i>	
Installation methodology	Plough, trencher or jetter (using pre- or post-lay burial techniques)
Target burial depth	1m
Width of seabed affected by array cable installation	25m
Total seabed disturbance	6,250,000m ²
Burial spoil: ploughing and jetting	500,000m ³
Duration: per array link (hours) – Jetting	Approximately 12hrs
Duration: per array link (hours) – Ploughing	Approximately 30hrs
Duration: total (months)	12 months
Jetting excavation rate – soft soil	300m/hr
Jetting excavation rate – loose soil	125m/hr
Ploughing excavation rate – medium soil	125m/hr
Ploughing excavation rate – hard soil	50m/hr
<i>Cable protection placement</i>	

Assessment assumption or parameter	Maximum value (Parameters presented in bold text)
Cable protection area	300,000m²
Cable protection volume	175,000m³
Number of crossings (estimate)	4
Cable/pipe crossings: total impacted area	10,000m²
Cable/pipe crossings: pre-lay rock berm volume	10,000m³
Cable/pipe crossings: post-lay rock berm volume	10,000m³
Height of cable protection berm	1m
Width of cable protection berm	6m
Proportion of array cable requiring protection	20%
Replenishment during operations (% of construction total)	25%
Cable rock protection: maximum rock size	0.3m
<i>Vessel requirements</i>	
Number of main laying vessels	3
Number of main burial vessels	3
Number of trenching vessels	2
Number of crew boats or SOVs	6
Number of service vessels for pre-rigging of towers	2
Number of diver vessels	2
Number of vessels for Pre-Lay plough	2
Number of dredging vessels	1
Main laying vessels (total number of return trips)	12

Assessment assumption or parameter	Maximum value (Parameters presented in bold text)
Main burial vessels (total number of return trips)	6
Support vessels (total number of return trips)	300

Installation of interconnector cables

4.3.73 Like the installation of array cables, the installation of the interconnector cables is expected to require either ploughing, trenching, jetting, or a combination of these techniques. **Table 4-16** provides the assessment assumptions for the installation of the offshore interconnector cables.

Table 4-16 Maximum offshore interconnector cable installation assessment assumptions and parameters

Assessment assumption or parameter	Maximum value (Parameters presented in bold text)
Cable protection area	122,000m²
Cable protection volume	110,500m³
Installation methodology	Plough, trencher or jetter
Target burial depth	1m
Total seabed disturbance	1,000,000m ²
Burial spoil – jetting	80,000m ³
Burial spoil – ploughing / trenching	80,000m ³
Jetting excavation rate – soft soil	300m/hr
Jetting excavation rate – loose soil	125m/hr
Ploughing excavation rate – medium soil	125m/hr
Ploughing excavation rate – hard soil	50m/hr
Trenching machine excavation rate - soft soil	200m/hr
Trenching machine excavation rate - hard soil	50m/hr

Export cable installation

- 4.3.74 Similar to the installation of array cables and interconnector cables, the installation of the export cables is likely to involve the burial of the cables below the seabed using ploughing, trenching, or jetting. It is anticipated that a combination of these three methods may be used depending on seabed conditions. No crossings are required along the export cable route. Installation is likely to involve the following activities:
- jet-trenching;
 - pre-cut and post-lay ploughing or simultaneous lay and plough;
 - mechanical trenching (such as chain or wheel cutting);
 - dredging (typically trailing hopper suction dredging (THSD) and backhoe dredging or water injection dredging);
 - mass flow excavation;
 - rock cutting;
 - burial sledge;
 - surface laid / self-burying cable;
 - cable installed in pipe / duct; and
 - cable protection installed, where necessary.
- 4.3.75 Duct extensions may be required to enable the landfall HDD ducts (see **paragraph 4.4.1**) to be extended further offshore to facilitate cable installation from an installation vessel situated offshore. These duct extensions will be of a similar diameter to the HDD ducts and installed in their own trench at a similar depth of cover to the export cables. The duct extensions will be backfilled before the arrival of the cable installation vessel.
- 4.3.76 In shallow water sections of the export cable route, where ground conditions are not suitable to 'ground out' the export cable installation vessel on the seabed, the construction of temporary sand / gravel beds may be required. These beds will allow the vessel to safely 'ground out' before pulling and installing the cables. Following cable installation, these sand/gravel beds will be removed.
- 4.3.77 The cables will be manufactured at a specialist supplier's factory. The manufactured cables will be spooled from the factory to cable carousels situated on a transport vessel or directly onto the installation vessel itself, moored at the adjacent quayside. If a transport vessel is used, the cables will be subsequently transpoiled onto the installation vessel at a local port before it transits to the Proposed Development site for installation.
- 4.3.78 The maximum total seabed area that may be disturbed by the installation of export cables amounts to approximately 2,015,000m². **Table 4-17** provides additional details on installation assessment assumptions for the export cables and vessel requirements.

Table 4-17 Maximum export cable installation assessment assumptions and parameters

Assessment assumption or parameter	Maximum value (Parameters presented in bold text)
Export cable installation	
Cable protection area	517,000m²
Cable protection volume	470,000m³
Installation methodology	Plough, trencher or jetter
Area of temporary sand/gravel beds for grounding installation vessel	115,000m ²
Volume of temporary sand/gravel beds for grounding installation vessel	57,600m ³
Total seabed disturbance	4,250,000m ²
Burial spoil – jetting	340,000m ³
Burial spoil – ploughing/ trenching	340,000m ³
Duct extensions (total length)	4km total (one duct per cable from HDD exit pit to approximately 1km further offshore)
Duration	6 months
Jetting excavation rate – soft soil	300m/hr
Jetting excavation rate – loose soil	125m/hr
Ploughing excavation rate – medium soil	125m/hr
Ploughing excavation rate – hard soil	50m/hr
Trenching machine excavation rate - soft soil	200m/hr
Trenching machine excavation rate - hard soil	50m/hr
Vessel requirements	
Jack-up area per leg	250m ²
Jack-up number of legs	6
Number of jack-ups per exit pit	2
Number of barge groundings per exit pit	2

Assessment assumption or parameter	Maximum value (Parameters presented in bold text)
Number of main laying vessels	2
Main laying vessels (total number of return trips)	6
Number of trenching machines	2
Number of main jointing vessels	2
Main jointing vessels (total number of return trips)	6
Number of main burial vessels	2
Main burial vessels (total number of return trips)	6
Number of multicat-type vessels (for excavating duct extensions)	4
Multicat-type vessels (total number of return trips)	16
Number of spoil barges (for duct extensions)	4
Spoil barges (total number of return trips)	60
Number of support vessels	10
Support vessels (total number of return trips)	60

4.4 Export cable landfall

Overview

- 4.4.1 The offshore export cables will come ashore at landfall between Middleton-on-Sea and Littlehampton at Climping. To reduce the impact of the landfall, a trenchless solution, HDD, is to be used to install ducts that will house the cables under Climping beach. The ducts will run from the Transition Joint Bay (TJB), located landward of the beach (shown in the locations of Works No.8 on the **Offshore Works Plans** (Document Reference: 2.2.1)) to the offshore export cables. TJBs are permanent below ground infrastructure where the offshore and onshore export cables are joined. A schematic diagram to illustrate how the ducts will be installed is shown in **Graphic 4-17**.

Graphic 4-17 Schematic of landfall crossing

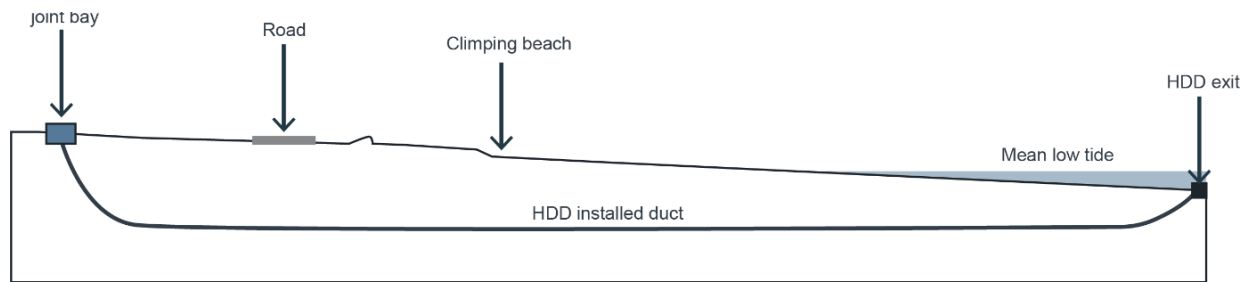

4.4.2 The offshore export cables will be pulled ashore through these pre-installed HDD ducts and will interface with the onshore cables at the TJB.

4.4.3 Landfall works include:

- construction of access to the Climping compound;
- construction of the Climping compound;
- HDD works (24-hour working);
- construction of TJBs;
- pull-in of High Density Polyethylene (HDPE) duct from barge;
- pull-in of offshore high voltage cables from vessel;
- transition jointing offshore / onshore cables;
- backfilling of joint bays; and,
- reinstatement works.

4.4.4 Offshore works include:

- excavation of HDD exit area and trench (if required);
- assembly of HDPE duct whilst being pulled through the HDD bore to the landfall;
- laying of additional length of ducting in trench (if required); and,
- capping and burial of HDD duct end.

Access to landfall and associated temporary construction compound

4.4.5 Main temporary construction access to the landfall will be from the north through an existing road (Ferry Road) connecting into the A259. An existing field access point will be upgraded. A temporary construction access haul road will be constructed along the cable route to a temporary construction HDD compound at landfall. This temporary road will allow movement of personnel and equipment to/from the landfall temporary construction HDD compound. The landfall temporary construction HDD compound and associated temporary construction accesses will be in place from the start of construction through to completion of final cable testing activities. Operational access associated with the area will be retained.

Construction

- 4.4.6 The landfall temporary construction compound will be located behind Climping beach either approximately 600m or 900m north-east of Atherington as shown by Works No.8 on the **Onshore Works Plans** (Document Reference 2.2.2). The flexibility in the location is sought to allow for ground investigation to be undertaken to inform the selection of the final location and account for the detailed design of the related offshore works. This compound will be used for the HDD activities, cable pulling and construction of the TJBs.
- 4.4.7 The landfall temporary construction HDD compound (approximately 100m x 120m) will be set up with required storage for materials and equipment, facilities for personnel, and area for temporary construction activities.
- 4.4.8 Prior to any construction, survey works and site clearance will be undertaken, this includes geotechnical, topographical, UXO and environmental surveys. The landfall temporary construction HDD compound site will be cleared (topsoil removal etc.) in line with environmental requirements, embedded mitigation measures described in the **Outline Code of Construction Practice** (Document Reference 7.2) and the temporary construction access haul road will be prepared.
- 4.4.9 In the landfall temporary construction HDD compound, up to four HDD pits will be dug to allow the HDD equipment to drill. Exit pits are required offshore and will be excavated by a shallow draft barge. A shallow draft barge such as that illustrated in **Graphic 4-18**, or similar, will be located at the exit point for a period of approximately 10 to 14 days while each HDD is completed, and each duct installed.
- 4.4.10 The export cable ducts will be installed underneath Climping beach using HDD. The drilling will start from the landfall temporary construction HDD compound for approximately 1km to exit below the mean low water spring tide (MLWS) mark. The location of the HDD exit point and therefore the length of the HDD is to be determined post-consent, following pre-construction surveys, further engineering, and offshore vessel considerations.

Graphic 4-18 Example shallow draft barge

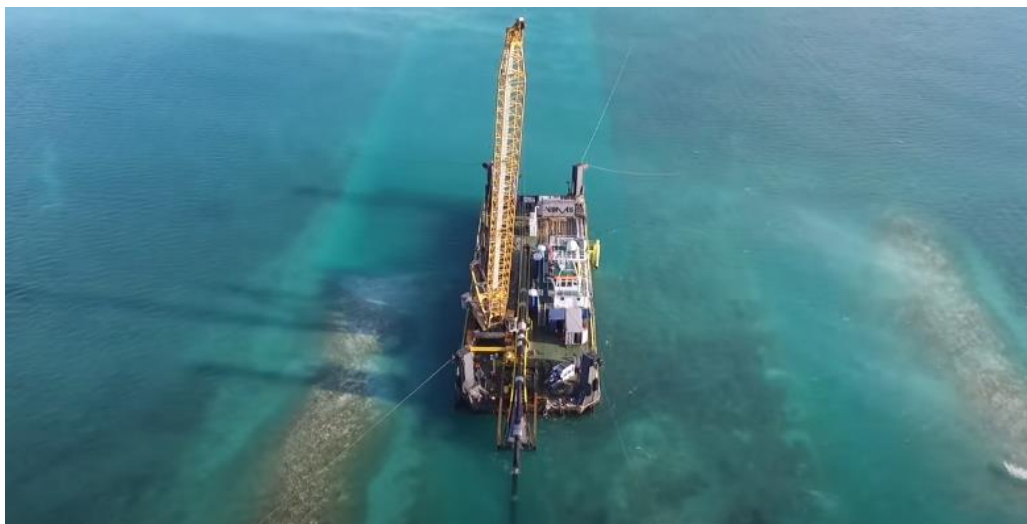

- 4.4.11 The ducts (with a messenger wire inside) will be pulled through to the landfall temporary construction HDD compound pit from the barge. Once complete the seaward duct end will be capped with the messenger wire inside. A detailed construction plan for the HDD work will be produced for agreement with the appropriate regulatory authorities prior to work commencement.
- 4.4.12 The offshore export cable will be joined to the onshore cable within the TJB. The TJB provides a clean, dry environment where the onshore and offshore cables are joined, and to protect the joints once completed. Four pits will be dug into the ground and lined with concrete. Once the joint is completed, the TJBs are covered and the land above reinstated. Access will be required during the operation and maintenance phase to link boxes (associated with each TJB).
- 4.4.13 The export cables will be pulled shoreward through the installed ducts by winching equipment stationed in the landfall temporary construction HDD compound. A cable lay barge will be stationed at the seaward duct end during the cable pulling activities. The seaward duct will be raised onto the vessel. The cable is attached to the messenger wire and pulled through the duct to the TJB. Once the cable reaches the TJB the cable lay vessel will commence the offshore cable lay. Following completion of the offshore and onshore cable installation, the cables will undergo final testing and commissioning.
- 4.4.14 Individual landfall construction activities (temporary construction HDD compound setup, HDD, TJB construction etc.) have relatively short durations compared with the overall landfall construction window presented in **Graphic 4-24**. Due to the landfall works requiring offshore works, the scheduling of the landfall works will allow for flexibility around the offshore schedule and sufficient time for all onshore activities to be performed so as not to delay the offshore works.

Table 4-18 Maximum export cable landfall assessment assumptions and parameters

Assessment assumption or parameter	Maximum value (Parameters presented in bold text)
Number of HDD drills	Up to four
Number of transition joint bays	Up to four
HDD cable ducts	Up to four
HDD exit pits number	Up to four

Reinstatement

- 4.4.15 Following successful testing of the cables at the TJB the landfall temporary construction HDD compound and temporary construction access track will be removed. The landfall site will be reinstated to the original condition and handed back to the landowner, this work will include the removal of all equipment and facilities, temporary fencing, haul road and reinstatement of topsoil.

4.5 Onshore elements of the Proposed Development

Overview

- 4.5.1 The onshore elements of the Proposed Development refer to works landward of MHWS and will comprise the following key components:
- a temporary onshore cable corridor, approximately 38.8km in length from the landfall at Climping to a new onshore substation at Oakendene, and from the new onshore substation to the existing National Grid Bolney substation, typically 40m in width within which the following will be located:
 - ▶ permanent infrastructure corridor width up to 25m³, or wider at HDD crossing locations, including HVAC transmission cables and associated joint bays; and
 - ▶ temporary infrastructure including trenchless crossing areas, temporary construction compounds and the associated access requirements.
 - A new onshore substation, to be located at Oakendene near Cowfold.
 - extension to and additional infrastructure at the existing National Grid Bolney substation to connect Rampion 2 to the national grid electrical network.
- 4.5.2 Some landfall works described in **paragraphs 4.4.2 to 4.4.15**, such as the landfall temporary construction HDD compound behind Climping beach, will also take place onshore.
- 4.5.3 The onshore part of the proposed DCO Order Limits, is illustrated in **Figure 4.2, Volume 3** (Document Reference 6.3.4).

Onshore cable corridor

Introduction

- 4.5.4 The onshore cable corridor is routed from the landfall at Climping through to a proposed new onshore substation at Oakendene, and then onto the existing National Grid Bolney substation (see **Figure 4.7, Volume 3** (Document Reference 6.3.4)). Design refinement of the onshore elements since the Scoping stage is described in **Chapter 3: Alternatives, Volume 2** of the ES (Document Reference 6.2.3). Kilometre points (KPs) have been provided in **Figure 4.6, Volume 3** (Document Reference 6.3.4).
- 4.5.5 The following sections present the maximum design assessment assumptions for the onshore elements of the Proposed Development.

³ A typical corridor easement is likely to be 20m, but this may vary according to local conditions. A maximum value of 25m (excluding HDD crossing locations) has been assessed as a reasonable worst case scenario.

Onshore cable design

- 4.5.6 The cable system (up to 275kV) along the onshore cable route will comprise a maximum of 20 buried cables arranged as four cable circuits in separate trenches. These will run along the length of the onshore cable route from the landfall at Climping through to the new onshore substation at Oakendene. Each circuit will contain three Power Cables (HVACs) and two Fibre Optic Cables (FOCs) drawn through pre-installed ducts.
- 4.5.7 The 400kV cable system between the new onshore substation at Oakendene and the existing National Grid Bolney substation will comprise a maximum of 10 buried cables arranged as two cable circuits in separate trenches. Each circuit will contain three Power Cables and two FOCs drawn through pre-installed ducts.
- 4.5.8 The standard temporary construction corridor will be up to 40m wide and consist of the trenches, excavated material and a temporary construction haul road. The temporary construction corridor may require widening beyond the standard width to allow enough space for access / equipment at trenchless crossings and to avoid obstacles. The proposed DCO Order Limits have been defined considering this enlargement at potential locations and to account for uncertainty in ground conditions at this stage. The standard temporary construction corridor is also reduced in certain locations for limited lengths as a result of constraints such as watercourses or woodland.
- 4.5.9 Sufficient space to provide adjacent temporary infrastructure such as construction drainage has also been included in the onshore part of the proposed DCO Order Limits.
- 4.5.10 For the connection from the onshore substation at Oakendene to the National Grid Bolney substation, where two cables are required, the corridor will not exceed 30m in width.
- 4.5.11 **Graphic 4-19** presents a cross section to illustrate the layout of a temporary construction corridor. The temporary construction corridor is generally routed as straight as possible to reduce overall length and to maximise the distance between JB (see **paragraph 4.5.18**) through lower friction between the cable and the ducts during cable pull.
- 4.5.12 Where necessary specific areas for cable stringing out have been included in the proposed DCO Order Limits and shown on the **Onshore Works Plans** (Document Reference 2.2.2). Cable stringing areas are a result of a construction method whereby the duct or cable is to be pulled through an HDD on the opposite side of the crossing from where the drill is located. The space needed for cable stringing needs to be at least the length of the drill and straight/follows the direction of the drill. If the cable route continues to be straight immediately following the crossing, the stringing out will occur within the working width of the cable route. On occasion, where the cable route changes direction immediately following an HDD, there is not sufficient space for stringing out. In this case we have allowed additional space following the likely direction of the drill to enable this stringing out.

Graphic 4-19 Temporary construction corridor cross section

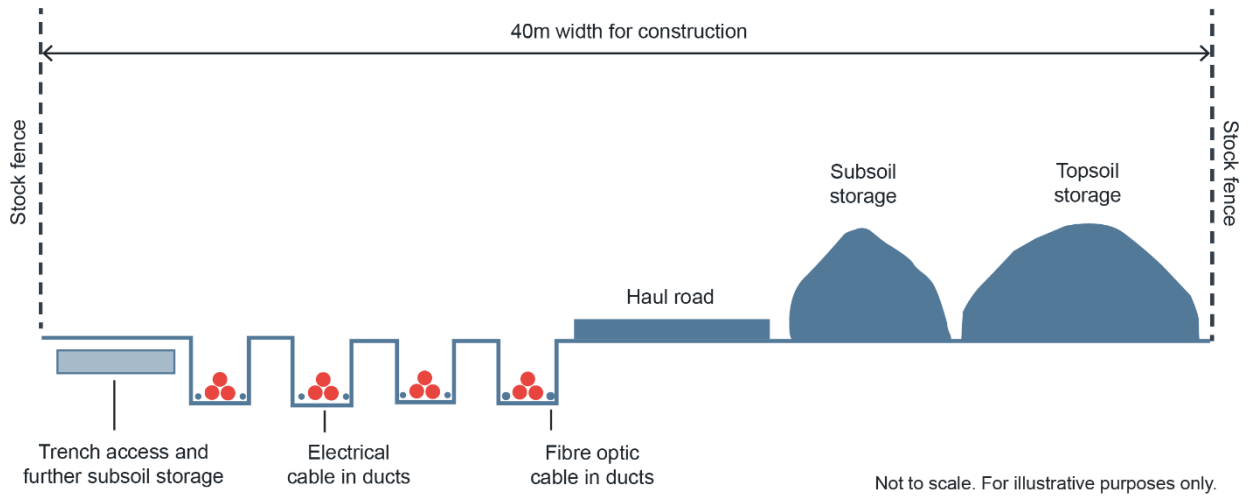

4.5.13 The temporary construction haul road will enable the transportation of plant used for topsoil stripping, subsoil excavation and for delivery of cable duct and cement bound sand (CBS) fill material. This soil will be stored in bunds within the temporary construction corridor, except for works in flood zones where specific soil storage areas have been provided to allow storage outside the floodplain as shown on the [Onshore Works Plans](#) (Document Reference 2.2.2). It is anticipated that a mechanical excavator will be used for these activities. **Graphic 4-20** and **Graphic 4-21** present the proposed trench profiles for hard solid ground and soil.

Graphic 4-20 Trench profile for hard/solid ground

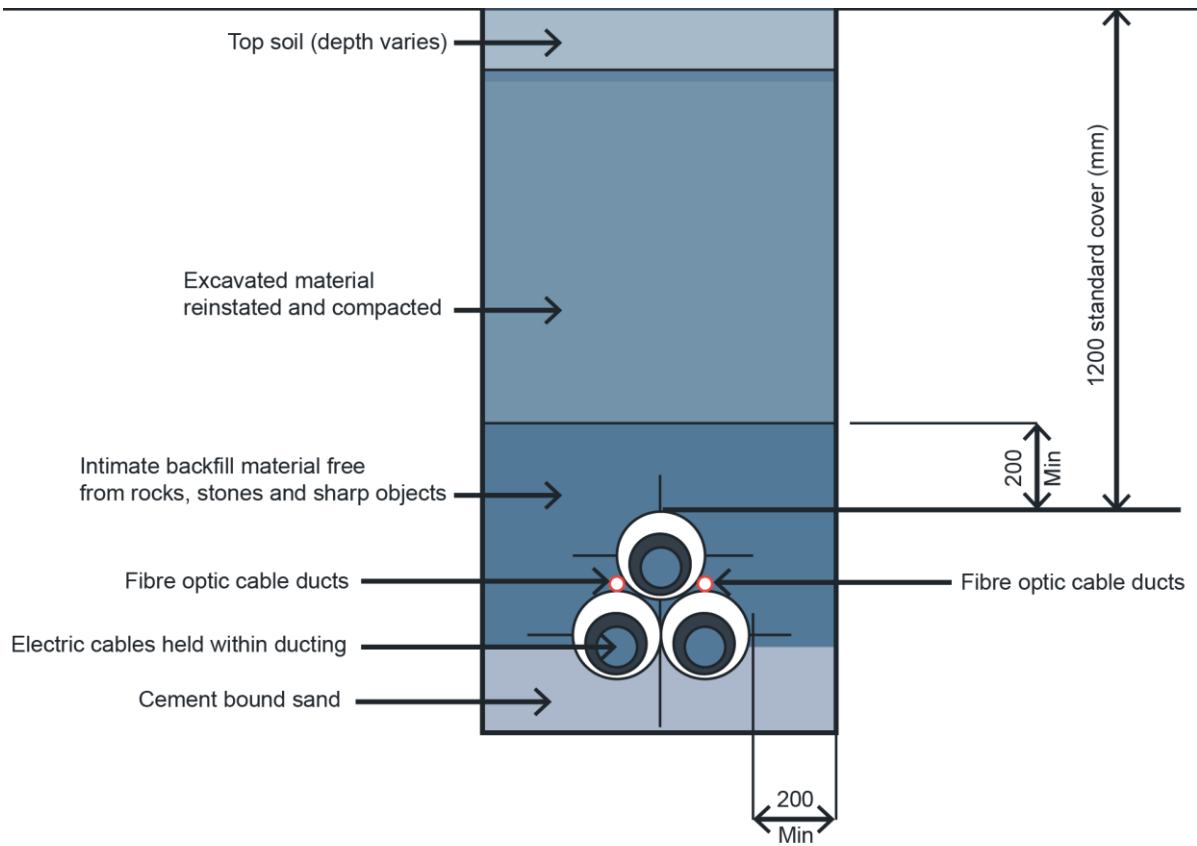

4.20_42285-WOOD-XX-XX-FG-O-0012_S2_P03.1_bermb_ai.

Graphic 4-21 Trench profile for soil

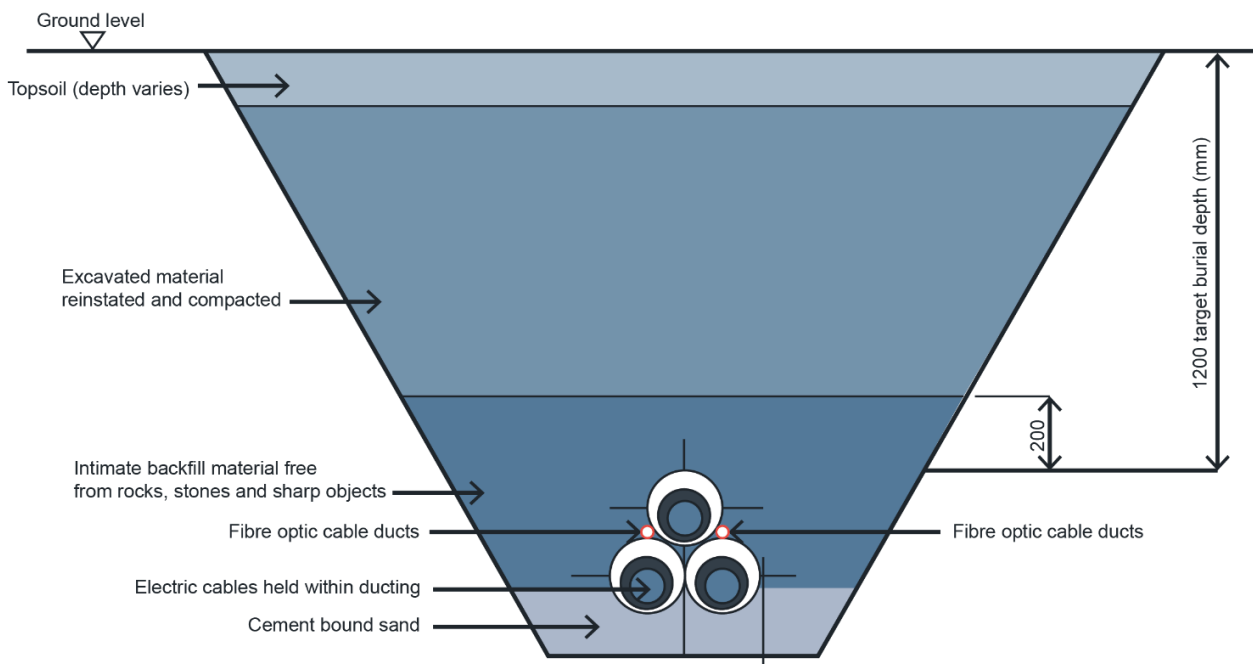

4.22_42285-WOOD-XX-XX-FG-O-0011_S2_P04.2_bermb_ai.

- 4.5.14 Where required, a layer of stabilised backfill (likely sandy material) will be deposited for the purposes of protection under the cable ducts. The cable ducts will then be positioned in the trenches.
- 4.5.15 Trenches will be backfilled with the originally excavated material or cement bound sand (CBS) to the layer of the protective tiles/tape (use of CBS is dependent on soil thermal resistivity). Protective cover tiles/tape will be placed on top of the material to prevent the cable from being damaged. The cable protection tiles used will comply with the Energy Networks Association (ENA) (2018) Technical Specification 12-23 (ENA TA 12-23). These will typically be made of plastic and will have clear warning of the underlaid cable written on top of the tile. Any surplus material from excavation will be spread across the temporary construction corridor. The topsoil material will be reinstated, and the land returned to its original use.
- 4.5.16 FOCs will be installed alongside the transmission cables for communication and monitoring purposes as illustrated in **Graphic 4-20** and **Graphic 4-21**. FOCs will be of an all dielectric design. The Power cable is likely to consist of an oversheath, a metallic sheath, a metallic screen, insulation and a conductor. Power cable cores are likely to be made of copper or aluminium with XLPE insulation.
- 4.5.17 The onshore cable corridor assessment assumptions are provided in **Table 4-19**.

Table 4-19 Maximum onshore cable corridor assessment assumptions and parameters

Assessment assumption or parameter	Maximum value (Parameters presented in bold text)
Trench width: at base	1.2m
Trench width: at surface	Between 2m and 4m dependant on soil strength. Maximum angle of trench dependant on soil strength. Hard/solid ground: Same as base trench width.
Corridor width: permanent (easement)	Up to 25m⁴
Corridor width: temporary (construction corridor width)	Up to 40m
Corridor area: permanent (easement)	Approximately 985,000m ² (98.5ha)
Corridor area: temporary (construction corridor width)	Approximately 1,576,000m ² (157.6ha)
Burial depth: minimum	1.2m cover to the top of the duct

⁴ A typical corridor easement is likely to be 20m, but this may vary according to local conditions. A maximum value of 25m (excluding HDD crossing locations) has been assessed as a reasonable worst case scenario.

Assessment assumption or parameter	Maximum value (Parameters presented in bold text)
Burial depth: maximum (for trenchless crossings)	Approximately 25m
Trench: depth of stabilised backfill	Approximately 0.7m
Onshore cable corridor length	Approximately 38.8km
Number of cables (including fibre optics)	Up to 20
Number of ducts (including fibre optics)	Up to 20
Number of trenches	Up to 4
Trenchless crossings (as per crossing schedule)	27 trenchless crossings which are likely to utilise HDD
HVAC: number of cable circuits	Up to 4
HVAC: number of cables	2 FOCs in each circuit, up to 8 FOCs in total, with up to 12 power cables – maximum 20 individual cables
Voltage	275kV landfall to Oakendene substation; 400kV from Oakendene substation to the existing National Grid Bolney substation
Diameter of 275Kv cable	150mm
Diameter of 400kV cable	160mm
Outside diameter of duct	250mm
Total installation duration	Approximately 36 months
Heavy Goods Vehicle (HGV) construction traffic movements (two-way) across the onshore cable corridor construction programme	Approximately 70,468

Joint bays and cable jointing

- 4.5.18 Along the onshore cable route, joint bays will be constructed to enable cable installation and cable jointing. The joint bays are subsurface structures with an associated subsurface link box and Fibre Optic junction box. These link boxes enable electrical checks and testing to be carried out on the cable system during operation and maintenance.
- 4.5.19 The locations of the joint bays will be determined during the detailed design phase. Typically, they are located every 750 to 950m however the location depends on

factors such as needing to avoid surface features, crossings and bends. **Graphic 4-22** presents an illustration of a typical joint bay configuration.

Graphic 4-22 Illustration of a typical joint bay configuration

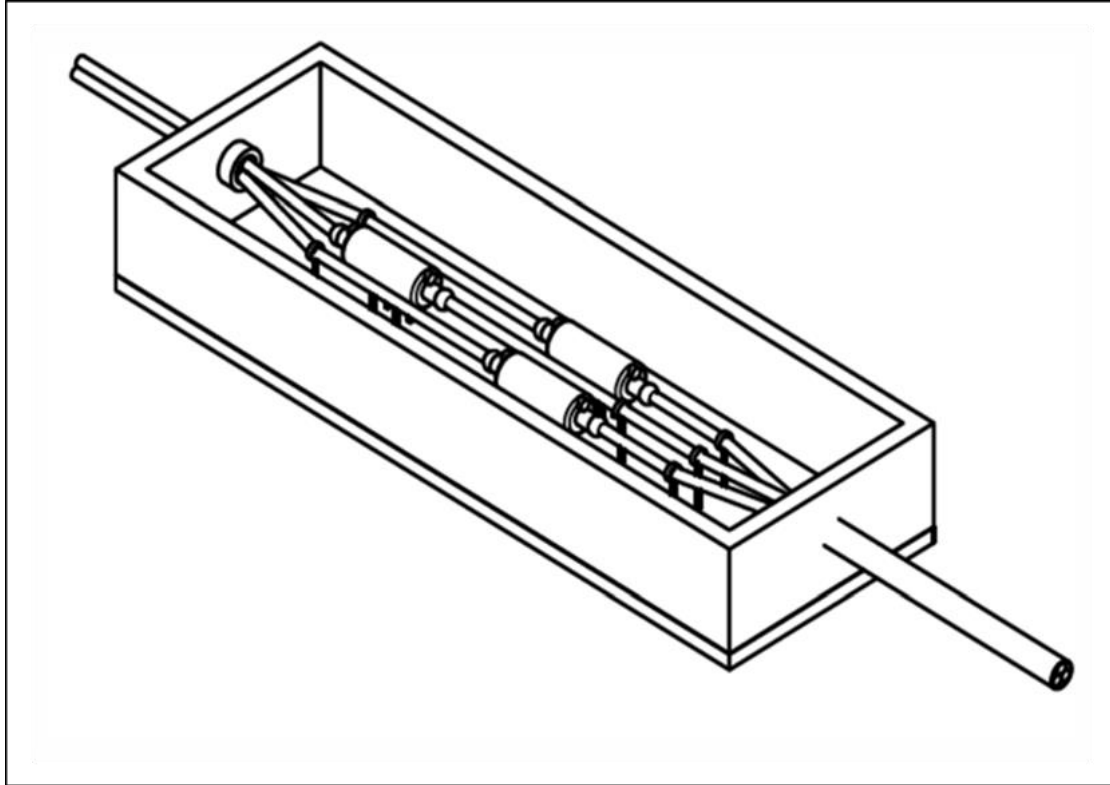

4.5.20 **Table 4-20** provides maximum design assessment assumptions for joint bays.

Table 4-20 Joint Bay, Link Box and Fibre Optic Cable Junction Box design assessment assumptions and parameters

Assessment assumption or parameter	Maximum value (Parameters presented in bold text)
Joint Bay (JB)	
Number of JB locations	Up to 66
Number of JBs per location	Up to 4
Max distance between JBs (on one circuit)	1,000m
JB width	4m
JB length	14m
JB area	56m ²
JB depth	Up to 2m

Assessment assumption or parameter	Maximum value (Parameters presented in bold text)
JBs – total area	14,784m ² (1.48ha)
Spoil volume per JB	Up to 118m ³
JBs – total spoil volume	31,152m ³
JB construction duration per location (does not include cable pulling duration)	6 to 8 weeks
Link Box (LBs)	
Number of LBs	264
Max distance between LBs (on one circuit)	1,000m
LB & Fibre Optic Cable Junction Box (FOCJB) dimensions (length & width)	2m x 2m
LB area	4m ²
LB depth	1m
LBs – total area	1,056m ²
Spoil Volume Per LB	4m ³
LBs – total spoil volume	1,056m ³
Fibre Optic Cable Joint Box (FOCJB)	
Number of FOCJBs	264
Maximum distance between FOCJBs (on one circuit)	1,000m
FOCJB dimensions (length & width)	2m x 2m
FOCJB area	4m ²
FOC JB depth	1m
FOCJB total area	1,056m ²
Spoil volume per FOCJB	4m ³
FOC JB total spoil volume	1,056m ³

Cable Clamping

- 4.5.21 There are some locations along the onshore cable route where the cable circuits will have to travel down some steep slopes. The cable itself is heavy and high mechanical loads can be generated in the cable at the top part of slopes by virtue of the cable wanting to travel down the slope under its own weight. In particular, these high mechanical loads can be subsequently transferred to the nearest adjacent joint and cause it to fail.
- 4.5.22 To mitigate this, cable clamping will be applied at appropriate locations, typically close to joint bay locations on the side where the downward slope occurs. This will involve the installation of concrete block (approximately 2m³ in volume) into an excavated pit below the planned burial depth of the cable. Bolted to the concrete block will be a number of metal cleats, through which each of the three cables per circuit will pass. These cleats will clamp the cables to the concrete block.
- 4.5.23 Once installed, the ground above these clamping arrangements will be reinstated as per the same specification as the rest of the onshore cable route.

Crossings

- 4.5.24 There are road, rail, water, footpaths, third party services, and other crossings along the onshore cable route. Each crossing will be individually reviewed/surveyed again during detailed design to confirm the crossing methodology employed. Open cut trenching crossing methodology will predominantly be used. This involves the preparation of the crossing (damming / fluming / pumping in the case of water courses) to allow the trenches to be excavated and ducts installed. The crossing area will be reinstated to the original form following the installation of cables. The crossings schedule is provided in [Appendix 4.1: Crossings schedule, Volume 4](#) of the ES (Document Reference 6.4.4.1). Traffic control measures and diversions will be implemented for open cut trench road crossings.
- 4.5.25 Similarly, open cut trench footpath crossings such as on the South Downs Way will be temporarily diverted where possible in a safe and controlled manner, with minimal disruption. Whilst there may still be a need for short-term closures, these will be communicated in advance and will be limited to the days where the onshore cable trench is first excavated (as described in the [Outline Public Rights of Way Management Plan](#) (Document Reference 7.8)).
- 4.5.26 For trenchless crossings, HDD has been assessed in the DCO Application as this is the likely preferred option based on their reduced complexity and relatively low cost compared to other techniques. The detailed methodology and design of the trenchless crossing will be determined following site investigation and confirmed within stage specific Onshore Construction Method Statements including confirmation that there are no new or materially different environmental effects arising compared to those assessed in the ES.
- 4.5.27 Trenchless crossings will be used for main watercourses, railways and roads that form part of the Strategic Highways Network, although if necessary other trenchless methodologies will be considered. The Crossings Schedule details the proposed crossings for the onshore cable route and can be found in [Appendix 4.1 Crossings schedule, Volume 4](#) of the ES (Document Reference 6.4.4.1). [Figure](#)

4.3, Volume 3 (Document Reference 6.3.4) shows the location of all trenchless crossings on the onshore cable corridor including the flexibility to undertake the drill from either side of the crossing point. The figure shows areas within which the HDD compound would be located, referred to as the HDD limits of deviation. The compounds would use an area up to 50 x 75m within the limits indicated. Only one compound would be required per crossing with an exit pit at the other side of the crossing. The use of HDD methodology is less intrusive than open cut crossings from a crossing interaction, traffic management and environmental perspective, however the equipment used is louder and as it requires 24-hour working, proximity to noise receptors must be considered. Further details on the trenchless crossing technologies considered are described in **Chapter 3: Alternatives, Volume 2** of the ES (Document Reference 6.2.3).

- 4.5.28 The proposed DCO Order Limits have been widened in areas to accommodate the need for trenchless crossings at the locations defined in **Appendix 4.1: Crossings schedule, Volume 4** of the ES (Document Reference 6.4.4.1) and are presented in **Figure 4.3, Volume 3** (Document Reference 6.3.4). The compounds for trenchless crossings will be up to 50 x 75m with the landfall compound up to 120 x 100m, see **Table 4-22**, and are to be located within the area defined on the ES Assessment Boundary
- 4.5.29 HDD involves drilling a bore from one location to another under the crossing. Following completion of the bore the duct lengths are strung out and connected in a line of equal length to the crossing and pulled through. Each circuit will have separate HDDs. The configuration and design assumptions of the trenchless crossings will be determined during the detailed design phase and informed by the EIA process. **Graphic 4-23** shows an example of a planned trenchless crossing of the River Arun and the Chichester to Littlehampton railway line using a trenchless crossing of approximately 350m.

Graphic 4-23 Cross section of River Arun and the Chichester to Littlehampton railway line trenchless crossing

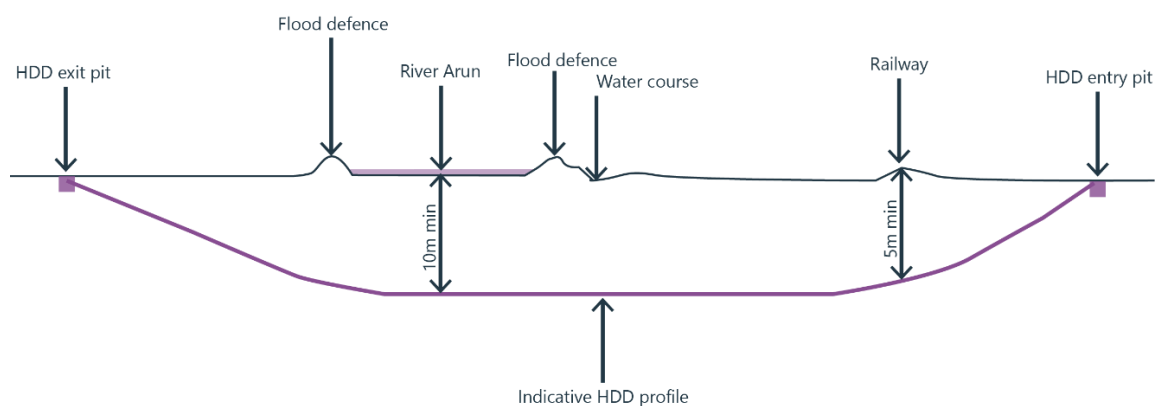

Temporary construction access and haul road

- 4.5.30 Temporary construction access points are required along the onshore cable corridor to allow the transportation of materials, equipment, and personnel to and from the construction sites. These temporary construction access points will allow access to the construction corridor where there will be a temporary construction

haul road running along the length of the onshore cable route, except for locations where there are trenchless or road crossings. **Figure 4.4, Volume 3** (Document Reference 6.3.4) presents the locations of all the proposed temporary construction access points along the onshore cable corridor. Key assessment assumptions of the temporary construction access and haul roads are presented in **Table 4-21**.

- 4.5.31 The use of temporary culverts, flume pipes or bridges may be required where obstacles are encountered along the haul road.
- 4.5.32 The temporary construction haul road will comprise crushed aggregates and a geotextile membrane where the existing ground is not considered stable enough. It will be used during installation works and construction activities and be removed prior to final reinstatement. Other construction methods for haul roads and access routes are identified in the **Outline Code of Construction Practice** (Document Reference 7.2).
- 4.5.33 Temporary construction access points are proposed along the onshore cable corridor based on suitability for the Proposed Development requirements, likely environmental and social impacts, highway safety and connection to key road infrastructure. Existing access points and tracks have been utilised where possible.
- 4.5.34 The temporary construction access points identified have been assessed for the effect on the road network, along with associated traffic management arrangements in **Chapter 23: Transport, Volume 2** of the ES (Document Reference 6.2.23). Further details on temporary construction access is documented in **Outline Construction Traffic Management Plan** (Document Reference 7.6).

Table 4-21 Maximum haul road assessment assumptions and parameters

Assessment assumption or parameter	Maximum value (Parameters presented in bold text)
Temporary construction haul road width	6m
Temporary construction haul road width – passing places	8m
Aggregate depth	Approx. 0.3m

Temporary construction compounds

- 4.5.35 Temporary construction compounds are required for:
- landfall works (see **paragraph 4.4.3**);
 - trenchless crossings; and

- logistics; storage of materials and equipment, location of cement bound sand (CBS) batching plant, also includes welfare facilities and office space as appropriate.
- 4.5.36 All temporary construction compounds are located within the proposed DCO Order Limits and are shown on **Figure 4.5 a-c, Volume 3** (Document Reference: 6.3.4). Temporary construction compounds for trenchless crossings (HDD compounds) typically have an area of 50m x 75m.
- 4.5.37 Along the onshore cable route five sites have been identified as locations for temporary construction or logistic compounds. Following completion of constructions works, the temporary construction compound facilities will be removed, and each compound site will be returned to its original state. Temporary construction compound details are provided in **Table 4-22**.
- 4.5.38 A temporary construction management base for supporting the construction of the offshore windfarm is still being determined and is assumed to be located within the port of Shoreham. **Chapter 23: Transport, Volume 2** of the ES (Document Reference 6.2.23) and subsequent chapters reliant on this information have taken all HGV and LGV journeys for this base into consideration.

Table 4-22 Construction compounds maximum assessment assumptions and parameters

Assessment assumption or parameter	Maximum value (Parameters presented in bold text)
<p>Number and area of onshore cable corridor main compound areas (as shown on Works No.10, Onshore Works Plans (Document Reference 2.2.2)).</p>	<p>Five:</p> <ul style="list-style-type: none"> • Climping Compound – approximately 61,300m² (6.13ha) for the cable installation temporary construction compound. • Washington Compound – approximately 39,100m² (3.91ha) for the cable installation temporary construction compound. • Oakendene substation compound – approximately 25,000m² (2.5ha) for the substation temporary construction compound • Oakendene west compound – approximately 50,000m² (5ha) for the cable installation temporary construction compound. • Existing National Grid Bolney substation compound – approximately 3,500m² for the existing National Grid substation extension temporary construction compound.
<p>Temporary construction compound dimensions (length and width)</p>	<p>Vary depending on the compound</p>

Assessment assumption or parameter	Maximum value (Parameters presented in bold text)
Temporary construction compound use duration per compound	Approximately 3 years and 6 months
Trenchless crossing compounds (length and width)	Up to 50m x 75m
Trenchless crossing compound at landfall (length and width)	Up to 120m x 100m
Trenchless crossing compound construction duration per compound (does not include cable pulling duration)	Approximately 3 to 4 months

Pre-construction

- 4.5.39 Pre-construction activities are “onshore site preparation works” to secure and prepare all sites and access for the construction activities. These operations consist of:
- site clearance,
 - demolition,
 - pre-planting of landscaping works,
 - archaeological investigations, which may include intrusive investigations including archaeological trial trenching, as described in the [Outline Onshore Written Scheme of Investigation](#) (Document reference 7.9).
 - environmental surveys in accordance with the [Outline Code of Construction Practice](#) (Document Reference 7.2) and [Outline Landscape and Ecology Management Plan \(LEMP\)](#) (Document Reference 7.10) which include commitments for ecological surveys and vegetation retention plans,
 - investigations for the purpose of assessing ground conditions,
 - remedial work in respect of any contamination or other adverse ground conditions,
 - diversion and laying of services,
 - erection of any temporary means of enclosure,
 - creation of site accesses; and
 - the temporary display of site notices or advertisements;
- 4.5.40 Temporary means of enclosure such as fencing will be used to mark out the onshore cable corridor area. Vegetation will be cleared, where appropriate, from the working width of the onshore cable corridor at the appropriate time of year.

Construction

- 4.5.41 Construction along the onshore cable corridor will be performed with the commitment to a safe work site and to minimise potential impacts as much as practicable. Generally, where possible construction will take place during daylight hours with a requirement only for local task lighting. The high-level construction sequence is as follows:
- excavate trenches;
 - connect ducts and place the ducts in the trenches;
 - trenches will be backfilled with an initial layer of fine protective material, overlaid by stockboard and a well-compacted thermally rated indigenous backfill; and
 - reinstatement of the topsoil.
- 4.5.42 In parallel to the above sequence, the joint bays (JBs), Fibre Optic Cable Joint boxes (FOC JB) and link boxes (LBs) will be constructed. This involves:
- excavation and
 - associated civil works.
- 4.5.43 The JBs, FOC JB, and LBs will remain open; ready for cable installation. Following cable installation and testing, they will be backfilled, and the working area reinstated. Further details on the assessment are provided where appropriate in the land-based aspect chapters such as **Chapter 18: Landscape and visual impact, Volume 2** of the ES (Document Reference 6.2.18), **Chapter 20: Soils and agriculture, Volume 2** of the ES (Document Reference 6.2.20), **Chapter 22: Terrestrial ecology and nature conservation, Volume 2** of the ES (Document Reference 6.2.22), and **Chapter 24: Ground conditions, Volume 2** of the ES (Document Reference 6.2.24).
- 4.5.44 Access to all construction sites will be managed throughout the construction phase with suitable supervision provided at access points to the onshore cable route, and temporary construction compounds. Access to all construction sites will be managed by the construction contractor. Where open cut trenching methodology is used for road crossings, traffic management will be in operation.

Cable installation and testing

- 4.5.45 Following construction of the onshore cable route, with installation of the ducts and JBs, the cables will be installed. Each cable is pulled from one JB to the next (approximately 750 to 950m distance). Testing will be performed to confirm the section of installed cable. This sequence repeats for all cables (HVAC and FOC) and for each circuit along the entire length of the cable route. Once the onshore and offshore cable installation is complete final testing / commissioning will be undertaken. Further details on joint bays are provided in **paragraph 4.5.18**.

Construction lighting regime for the onshore cable and substation

- 4.5.46 External lighting of the construction site for both the onshore cable and the new onshore substation will be directional. The work will usually be scheduled during daylight hours. If night or 24-hour working is required, such as during trenchless

crossing operations, then portable directional task lighting will be deployed. Further detail regarding construction lighting is provided in the **Outline Code of Construction Practice (CoCP)** (Document Reference: 7.2).

- 4.5.47 External lighting of the construction site will be designed and positioned to:
- provide the necessary levels for safe working;
 - minimise light spillage and / or light pollution; and
 - avoid disturbance to adjoining residents / occupiers of buildings and to wildlife.
- 4.5.48 At temporary construction compounds and specific locations where night working is required or in poor light conditions during normal working hours, portable lighting units will be used where necessary to ensure safe working and / or site security.
- 4.5.49 Site or welfare cabins, equipment and lighting will be sited to minimise visual intrusion as far as is consistent with the safe and efficient operation of the work site. Site lighting will be positioned and directed to minimise glare and nuisance to residents, walkers and to minimise distractions or confusion to passing drivers on railways or adjoining public highways. Implementation will comply with the requirements set out in the following standards and guides as far as it is reasonably practicable and applicable to construction works:
- British Standard (BS) *EN 12464-2:2014 Light and lighting. Lighting of work places. Outdoor work places*;
 - Institute of Lighting Professionals, (2021). *Guidance Note 1 for the Reduction of Obtrusive Light*;
 - Chartered Institute of Building Services Engineers (CIBSE), (2018). *Society of Light and Lighting Guide 1: The Industrial Environment* ; and
 - CIBSE, (2016). *Society of Light and Lighting Guide 6: The Exterior Environment* .
- 4.5.50 When lighting is necessary, appropriate lighting units will be designed to minimise spillage of illumination outside the construction works area into surrounding habitats (e.g., lighting will be directional, task orientated and where possible, fully shielded). This is to minimise the impact of lighting on ecological resources, including nocturnal species. Further details regarding lighting during the construction phase will be developed with the construction contractor.

Onshore transformer substation

Introduction

- 4.5.51 The purpose of the new onshore substation at Oakendene is to increase the onshore cable route voltage to the 400kV required to connect to the existing National Grid Bolney substation. **Figure 4.8, Volume 4** (Document Reference: 6.3.4) illustrates the location of the new onshore substation at Oakendene.
- 4.5.52 The maximum footprint for the proposed onshore substation at Oakendene will be up to 6 hectares (ha) within the onshore substation site boundary. The remaining site area includes a combination of land to be reinstated and handed back to the

landowner and landscaping and drainage works as shown on the **Oakendene onshore substation - Indicative Landscape Plan** in Appendix D of the **Design and Access Statement** (Document Reference 5.8) and to be developed at detailed design in accordance with the design principles in the **Design and Access Statement** (Document Reference 5.8). The onshore substation will comprise electrical components and equipment necessary to connect the electricity generated by the Proposed Development to the existing national electricity transmission network. These include:

- transformers;
- reactors;
- capacitor banks;
- open busbars;
- Air Insulated Switchgear (AIS);
- Gas Insulated Switchgear (GIS);
- fire walls;
- reactive compensation equipment;
- harmonic filters;
- High Voltage (HV)/Medium Voltage (MV) equipment;
- switch room;
- control building; and
- welfare facilities.

4.5.53 Some equipment will be placed outdoors and other equipment will be housed in buildings or enclosures.

4.5.54 An indicative layout for an onshore substation is illustrated in **Appendix A Oakendene onshore substation indicative layout and elevation** of the **Design and Access Statement** (Document Reference 5.8). The final layout may not entirely align with the indicative layout but will be subject to the maximum design parameters presented in **Table 4-23**.

Table 4-23 Maximum assessment assumptions and parameters for the onshore substation

Assessment assumption or parameter	Maximum value (Parameters presented in bold text)
Permanent area of site for all infrastructure	Up to 6ha
Temporary works area	Up to 2.5ha
Maximum main building height	12.5m

Assessment assumption or parameter	Maximum value (Parameters presented in bold text)
Maximum height of fire walls	10m
Lightning protection mast height	18m
Maximum number of buildings	12
Maximum length building	70m
Maximum width of building	20m
Duration of construction	Approximately 3 years

Installation

- 4.5.55 Access to the onshore substation will be required during construction as well as operation and maintenance. The temporary construction access (**Outline Construction Traffic Management Plan** (Document Reference: 7.6)) will be used for the duration of the onshore substation construction works and will remain as a permanent access during the operation of the substation site. Site access works will involve stripping topsoil. The topsoil will be protected and stored nearby for the duration of the onshore substation construction works.
- 4.5.56 Construction activities for the onshore substation will include enabling works and construction works. Enabling works will prepare the site ahead of construction and include vegetation clearance, access road construction, installation of drainage systems, stone fill, installation of a construction compound, temporary site offices, fencing, delivery of materials, plant, machinery and fuel.
- 4.5.57 Generally, onshore substation construction will take place during daylight hours with a requirement only for local task lighting. Construction works will involve:
- installation of perimeter fencing;
 - ground preparation works;
 - installation of underground services and onshore substation foundations;
 - construction of the control and switchgear buildings and plant buildings;
 - construction of cable trenches;
 - construction of ducts and pits;
 - construction of the oil containment bund;
 - provision of utility supplies; and
 - Landscaping and drainage works;
- 4.5.58 Once all construction activities have been carried out, the electrical equipment will be installed, commissioned and tested for the performance of the connection

between the offshore windfarm, the new onshore substation at Oakendene and the existing National Grid Bolney substation. Finally, the site will be secured, and the temporary area returned to its original use and condition.

- 4.5.59 It is anticipated that HGVs will be required during the enabling and construction phases of the development. Abnormal indivisible load movements are expected to be required during the construction phase to transport permanent plant and equipment to the site. The expected movements are detailed in **Table 4-24**. Further details on the delivery of abnormal loads will be detailed in the Abnormal Loads Assessment in **Appendix 23.1: Abnormal Indivisible Loads assessment, Volume 4** of the ES (Document Reference: 6.4.23.1).

Table 4-24 Maximum HGV and abnormal loads assessment assumptions and parameters for the substation

Assessment assumption or parameter	Maximum movements (Parameters presented in bold text)
HGV construction traffic movements (two-way)	Approximately 11,438
Abnormal Indivisible Loads (two-way)	Up to 10

- 4.5.60 Abnormal Indivisible Loads (AILs) will be comprised of:
- Up to 4 main transformers; and
 - Up to 6 shunt reactors.

Grid connection export cable

- 4.5.61 A buried cable connection is required from the proposed Oakendene onshore substation to the existing National Grid Bolney substation (see **Graphic 4-1**). This connection will comprise a maximum corridor of two circuits with a total of six single core 400kV and four FOCs, all placed within a corridor up to 30m wide. The construction methodology for this grid connection will be the same as the methodology outlined for the cable route in **Paragraph 4.1.1** from the landfall to the onshore substation.

4.6 Onshore grid connection

Introduction

- 4.6.1 New infrastructure is required at the existing National Grid Bolney substation to provide a cable connection from the proposed Oakendene substation to the existing National Grid Bolney substation as the National Grid interface location. **Figure 4.7, Volume 3** (Document Reference: 6.3.4) illustrates the location of the extension to Bolney substation.

- 4.6.2 There are two types of infrastructure being considered for installation that will require installation as part of the Bolney substation extension works: Air Insulated Switchgear (AIS)⁵; or Gas Insulated Switchgear (GIS)⁶. The Bolney substation extension options are described further in **paragraphs 4.6.4 to 4.6.8**. Only one of the Bolney substation extension options (AIS or GIS) will be required in the final Proposed Development. As the final choice of infrastructure and its design will be determined by National Grid Electricity Transmission (NGET), the ES considers the design scenarios for each option based on the information available and assesses the maximum design scenario for both options, see **paragraphs 4.6.4 to 4.6.8**.
- 4.6.3 At this stage, the description of the Bolney substation extension works is indicative and a 'design envelope' approach has been adopted, further details are provided in **Section 4.1**.

Description of Bolney substation extension options

- 4.6.4 The Bolney substation extension AIS/GIS option specifications are described in turn below to provide an overview and **Table 4-25** outlines the maximum design assumptions of key parameters that are utilised in the environmental assessment. National Grid are responsible for owning and maintaining the high voltage electricity network in England and will select the most suitable option for the Bolney substation extension based on environmental conditions, feasibility, and engineering cohesion with the existing Bolney substation in discussion with RED. The temporary construction compound and the area for extension works required for either option will be located in a similar location with only the size of the extension works area being larger for the AIS option (see **Figure 4.7, Volume 3** of the ES (Document Reference: 6.3.4). The AIS option utilises air to insulate the switchgear whilst GIS utilises a gas medium to insulate the switchgear. Using a gas medium allows for smaller size equipment to be achieved and so a small extension area footprint would be required for the GIS option. The AIS/GIS options require similar types and scale of construction works the maximum assessment assumptions are presented in **Table 4-25**. The AIS option proposed would not require the construction of a building to house the equipment, alternatively the GIS option would require building constructed to house the equipment.

AIS extension option

- 4.6.5 The footprint for an AIS substation would be approximately 6,300m² (0.63ha). The existing Bolney substation comprises of an area of approximately 109,000m² (10.9ha), therefore the AIS option extension would increase the substation area by approximately 5.6%. The AIS extension would comprise electrical components and equipment necessary to connect the electricity generated by Rampion 2 to the existing National Grid network. The infrastructure required for the AIS option would

⁵ AIS – high voltage electrical switchgear infrastructure, whereby the majority of the equipment utilises air as the insulating medium.

⁶ GIS – high voltage electrical switchgear infrastructure, whereby the majority of the equipment utilises an inert gas (with strong insulating properties) as the insulating medium.

be situated outdoors in the substation extension area. The works to deliver include:

- removal of fencing from existing perimeter and erection of new fencing along the newly established perimeter;
- erection of two new AIS bays to connect the two 400kV circuits from the new onshore substation at Oakendene;
- AIS bays to each include a building of up to 12m in length, 3m in width and 3m in height (each approximately the size of an International Standards Organisation (ISO) container);
- extension of the existing busbars present at the existing National Grid Bolney substation to connect to the two new AIS bays; and
- vegetation screening to minimise views of the extension to the south (as part of C-254).

4.6.6 An indicative location plan for the AIS extension to the existing National Grid Bolney substation is illustrated in **Figure 4.7, Volume 3** of the ES (Document Reference: 6.3.4). The final layout may not entirely align with the indicative layout but will be subject to the maximum design scenario presented in **Table 4-25**.

GIS extension option

4.6.7 The footprint for a GIS substation would be approximately 3,500m² (0.35ha). The GIS option extension would increase the substation area by approximately 3.2%. The GIS extension would comprise electrical components and equipment necessary to connect the electricity generated by Rampion 2 to the existing National Grid network. A majority of the infrastructure required for the GIS option would be housed internally within a new building. The works to deliver include:

- removal of fencing from existing perimeter and erection of new fencing along the newly established perimeter;
- erection of a new steel-frame GIS building of up to 35m in length, 20m in width and 12m in height containing two GIS bays to connect the two 400kV circuits from the new onshore substation at Oakendene;
- extension of the existing busbars present at the existing National Grid Bolney substation to connect to the two new GIS bays; and
- vegetation screening to minimise views of the extension to the south (as part of C-254).

4.6.8 An indicative location plan for the GIS extension to the existing National Grid Bolney substation extension is illustrated in **Figure 4.7, Volume 3** of the ES (Document Reference: 6.3.4). The final layout may not entirely align with the indicative layout but will be subject to the maximum design scenario presented in **Table 4-25**.

Table 4-25 Maximum assessment assumptions and parameters for the extension to Bolney NG substation

Assessment assumption or parameter	AIS value	GIS value
	(Parameters presented in Bold)	
Permanent area of site for all infrastructure	0.63ha	0.35ha
Temporary construction works area (temporary construction compound and access)	0.72ha	0.72ha
Maximum building height	3m	12m
Maximum number of buildings	2	1
Maximum length building	12m	35m
Maximum width of building	3m	20m
Maximum height of other infrastructure	12m (busbars)	6m (interface asset to take the existing busbars into the GIS)
Duration of construction	Approximately 12 months	Approximately 12 months
Construction personnel	Approximately 21	Approximately 20
HGV construction traffic movements (two-way)	Approximately 968	Approximately 968

Installation

- 4.6.9 Access to the Bolney substation extension for either option (AIS or GIS) will be required during construction. The proposed temporary construction access route will follow an existing access from Wineham Lane to the temporary construction compound. This access will be extended from the temporary construction compound to the AIS or GIS substation extension area. Following construction, access for operation and maintenance will be through the existing Bolney National Grid substation.
- 4.6.10 A temporary construction compound will be required. This will be located along the temporary construction access on an area of existing hardstanding and will be approximately 3,500m² (0.35ha) (see **Figure 4.7, Volume 3** of the ES (Document Reference: 6.3.4). This compound will occupy the same area for either option.
- 4.6.11 Temporary construction activities for the Bolney substation extension will include enabling works and construction works. Enabling works will prepare the site ahead of construction and include vegetation clearance, access road construction,

installation of drainage systems, installation of a temporary construction compound, and delivery of materials, plant, machinery, and fuel.

- 4.6.12 Bolney substation extension construction will take place during standard construction hours with a requirement only for local task lighting. Construction works for the AIS and GIS options are described in the steps below and are broadly similar, only steps 6 and 8 differ:
1. establishing a temporary construction compound;
 2. building a temporary road from the temporary construction compound to the location of the permanent Bolney substation extension area;
 3. potential re-routing of existing services buried close to the existing National Grid Bolney substation, where works are planned;
 4. extension of the existing National Grid Bolney substation to NGET standards;
 5. erection of new fencing along the newly established perimeter;
 6. erection of switchgear bays:
 - ▶ AIS: erection of a two new AIS bays;
 - ▶ GIS: erection of a new steel frame GIS building containing two GIS bays;
 7. removal of fencing from existing perimeter;
 8. extension of busbars:
 - ▶ AIS: extension of the primary and secondary busbars within the existing National Grid Bolney substation to connect to the two new AIS bays; and
 - ▶ GIS: extension of the primary and secondary busbars within the existing National Grid Bolney substation to connect to the two new GIS bays.
- 4.6.13 The Bolney substation extension area is a relatively level site and minimal soil excavation is expected to be required. Any soil excavated will be reused where possible. At this stage, this cannot be confirmed and therefore the maximum design scenario assumes that any excavated soils will be removed from site.
- 4.6.14 The Bolney substation extension options will utilise concrete foundations for buildings and switchgear (both options), and piled or screwed foundations for busbar brushings (GIS option) or the AIS bays (AIS option). The ground material for both options will consist of a combination of crushed aggregate material overlaid with stone chippings.
- 4.6.15 Once all temporary construction activities have been carried out, the electrical equipment will be installed, commissioned, and tested for the performance of the connection between the new Oakendene onshore substation and the existing National Grid Bolney substation. Finally, the Bolney substation extension site will be secured, and the temporary construction areas returned to its original use and condition.
- 4.6.16 It is anticipated that construction traffic movements including HGVs and LGVs will be required during the enabling and construction Bolney substation extension

works. No abnormal indivisible load movements are expected to be required. The expected movements are detailed in **Table 4-25**.

4.7 Construction programme

- 4.7.1 An indicative construction programme for the Proposed Development is presented in **Graphic 4-24**. The programme illustrates the anticipated duration of the major construction / installation elements. The anticipated worst-case total construction duration for all onshore infrastructure to be complete, operational and for full landscape reinstatement is approximately four years. The Proposed Development will be delivered in stages, which are to be confirmed through the requirements in the **draft DCO** (Document Reference: 3.1).
- 4.7.2 The onshore cable route construction is detailed in **Graphic 4-24** which provides a breakdown of the anticipated construction periods for onshore cable route sections including the commissioning and reinstatement activities. Commissioning and construction timing descriptions are provided in **paragraphs 4.7.4 to 4.7.12** below.

Project programme

- 4.7.3 Should consent be granted in 2025, it is anticipated that access and construction of the project would commence later in 2025, with the project becoming operational in 2030 following completion of the substation and WTG commissioning work.

Graphic 4-24 Indicative construction programme

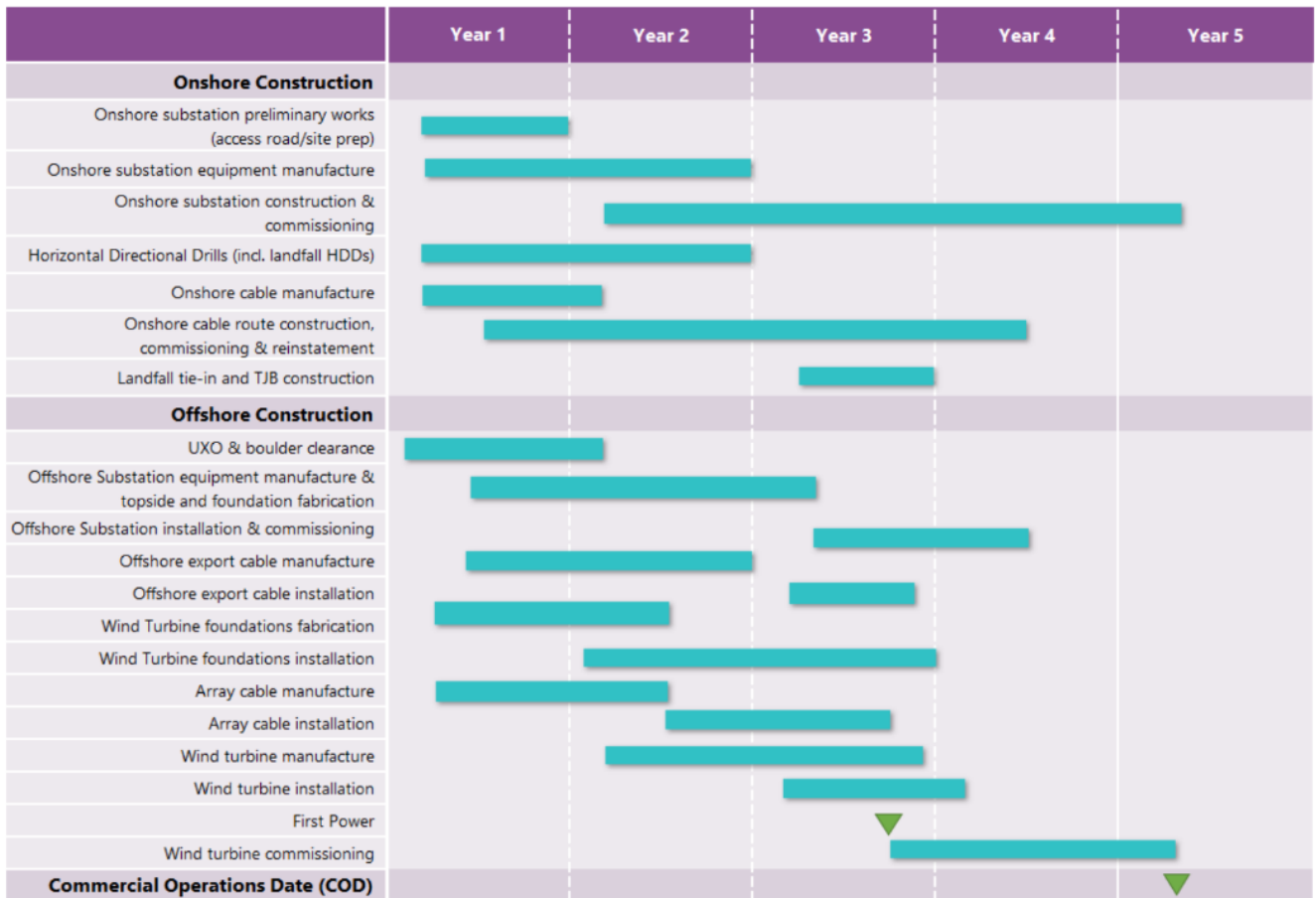

Commissioning

4.7.4 Commissioning is the process during the construction stage of assuring that all systems and components of the project are designed, installed, tested according to the requirements to enable safe operation. This will enable the Proposed Development to be connected to the existing National Grid Network and handed over to the team responsible for its operation. The majority of works will be carried out by technicians and commissioning engineers using handheld tools, though some larger specialist testing equipment will be required for some activities. The commissioning construction stage is included within **Graphic 4-24**.

National Grid Bolney substation compound

4.7.5 Commissioning works will principally cover the main high voltage equipment as with the Oakendene substation compound.

Oakendene Substation

4.7.6 Commissioning works will principally cover the main high voltage equipment before it is connected to the wider grid, but will also cover supporting systems including lighting, HVAC, plumbing, security, communications, SCADA, fire suppression etc. An example of this could be testing the ability of the transformer

bund to be able to hold oil from the transformer by pumping an equivalent volume of water into the bund and ensuring there were no leaks.

Export Cable Circuits

- 4.7.7 Commissioning works for the cable circuits are likely to involve the deployment of a specialist high voltage testing rig at the end of the circuits onshore. The test rig will be assembled from equipment housed on the back of heavy goods type vehicles. Tests will be conducted for a period of days to ensure in the integrity of the circuits before connecting them to wider grid.

Offshore Substations

- 4.7.8 Commissioning works are largely the same as those carried out at Oakendene Substation Compound, covering the high voltage equipment along with the supporting systems. These support systems will also cover additional items such as navigational lighting along with survival and rescue equipment, as required by the current regulations for offshore installations. Some works will be able to be completed onshore at the fabrication facility, but there will be many commissioning activities which will need to take place once the substations are installed offshore. To aid the efficient transport of engineers and technicians to complete the work on the offshore substations, it is common to use an accommodation vessel moored or jacked next to the substation to allow individuals to transit onto it using a gang way. This is typically needed for a period of months, depending on the overall commissioning scope and the weather conditions. Engineers and technicians will be rotated and ferried between the offshore substation and the shore via crew transfer vessels.

Array Cables

- 4.7.9 As per the export circuits, specialist high voltage test equipment may be deployed to ensure the integrity of the array cables before they are connected to the wider system. Depending on the voltage of the array cables, some of the test rig set up will be placed on a boat or potentially on the offshore substation.

WTGs

- 4.7.10 Teams of technicians and engineers will be used to commission WTGs. These will typically be based on an accommodation vessel or service operations vessel located within the WTG array. The technicians and engineers will transfer on each individual WTG to complete commissioning works for the particular working day. Typically it will take a period of days to complete these works ahead of a test generation period, the successful completion of which will see the WTG handed over into operations.

Construction timing

- 4.7.11 As secured in the [Outline Code of Construction Practice](#) (Document Reference: 7.2), core working hours for onshore construction works for the Proposed Development are as follows:

- 07:00 to 19:00 hours Monday to Friday;
- 08:00 to 13:00 hours on Saturday.

4.7.12 No activity outside of these indicative hours, including Sundays, public holidays or bank holidays will take place apart from under the following circumstances:

- where continuous periods (up to 24-hours, 7 days per week) of construction work are required for HDD;
- for other works requiring extended working hours such as concrete pouring which will require the relevant planning authority to be notified at least 72 hours in advance;
- for the delivery of abnormal loads to the connection works, which may cause congestion on the local road network, where the relevant highway authority has been notified prior to such works 72 hours in advance;
- where works are being carried out on the foreshore; or
- as otherwise agreed in writing with the relevant planning authority.

4.8 Operation and maintenance

Introduction

4.8.1 The operational lifetime of the Proposed Development is expected to be around 30 years. Taking place after commissioning of the Proposed Development, operation and maintenance activities can be divided into two main categories:

- scheduled maintenance;
- unscheduled maintenance; and

4.8.2 For the Proposed Development, RED will draw on experience gained by RWE in operating and maintaining Rampion 1. This includes identifying potential synergies when developing the operation and maintenance strategy for the Proposed Development.

4.8.3 A key principle is that the wind farm will be designed to operate under minimum supervisory input. The chosen operation and maintenance concept will depend upon:

- the required operation and maintenance tasks determined by the operator and/or agreed with the main equipment suppliers to maintain operability and availability of the wind farm;
- health, safety, security and environmental (HSSE) legislation and best practice;
- requirements or constraints imposed by public authorities or other authorities;
- site specific weather and metocean conditions;
- industry best practice; and
- optimum economic viability.

- 4.8.4 The EIA is based on reasonably foreseeable activities during operation and maintenance. Operation and maintenance activities will take account of general practices as described in plans including the **Outline Site Waste Management Plan** (Document Reference: 7.3) and **Outline Offshore Operations and Maintenance Plan** (Document Reference: 7.16).

Offshore operation and maintenance

- 4.8.5 The overall operation and maintenance strategy will be finalised once the operation and maintenance base location and technical specification of the Proposed Development are confirmed. It will require a harbour-based operation and maintenance base plus a combination of CTVs, Service Operation Vessels (SOVs), JUVs, heavy lift vessels, cable laying vessels and helicopters.
- 4.8.6 There will be scheduled services on each WTG and the offshore substations. These scheduled services will include:
- inspections;
 - system performance assessments;
 - oil and filter change outs;
 - bolt tensioning, and
 - statutory inspections, e.g. lifting and fire equipment inspections.
- 4.8.7 Scheduled and unscheduled maintenance activities will require access to the WTGs 365 days per year.
- 4.8.8 In addition to scheduled maintenance activities, experience shows that each WTG will need to be accessed by an operation and maintenance crew approximately (but not limited to) once a month. These visits are for activities such as fault-finding, manual hardware resets, minor repair jobs, and inspections of WTGs after lightning storms.
- 4.8.9 In addition to the maintenance of the WTGs it may be that remediation work will be required on the other wind farm components, for example survey and repair work to cables, foundations, WTG structures above and below the water, and the offshore substation platform(s).
- 4.8.10 Cable surveys and foundation inspections will initially be undertaken approximately every two years. The interval may increase if assets are proven to be stable, however more frequent and detailed surveys may be required if cables become exposed or due to the mobility of the seabed. The more detailed surveys could require dedicated surveying vessels. **Table 4-26** details the maximum design assumptions for operational and maintenance activities and **Table 4-27** presents the maximum operation and maintenance vessel assessment assumptions for operation and maintenance.
- 4.8.11 Although expected to be very infrequent through the life of the Proposed Development, it may be necessary to replace some of the larger components of the WTGs in the event of failure or breakdown. The possible replacements can be systematic change of bearings, transformer, blades, generator or gearbox. As the size of some of these components is too large to be handled by the service

vessels, jack up barges with mobile crane or larger special ships will need to be used.

4.8.12 Maintenance and remedial work on WTGs, foundations and cables will involve the following:

- painting and application of coatings of WTGs and transition pieces will be required for corrosion protection, which will be carried out by technicians using hand-tools. Surface preparation is required to break down existing surface coatings and any existing corrosion. There will be one full paint job per WTG every 10 years, and one touch-up paint job per WTG every three years;
- marine growth and bird waste will be physically brushed off WTGs and offshore substation structures by hand, using a brush, and if required, a high-pressure jet wash (using sea water only). There will be up to five cleaning events per WTG and offshore substation per year;
- access ladders may require replacing due to damage or corrosion. One ladder replacement is anticipated every five years;
- sacrificial foundation anodes will be installed on the foundation below the water level for corrosion protection. These will require replacement by divers from a support vessel every five years;
- the J-Tubes and I-Tubes (a tube that surrounds the cable for protection) will occasionally require repair or modification after being cut for cable repairs;
- cable remedial burial on array, interconnector and export cables may be required if they have become exposed during natural sediment transport processes;
- where rock protection has been applied to cables during the construction phase, this may require replenishing due to natural processes. It is anticipated that up to 25% of original protection will be replenished over its lifetime; and
- the cable route will be designed and installed to require no reburial through life. However, array, interconnector and export cables infrequently develop faults in service which are detected by the wind farm protection systems, and reburial has been required on other projects and should be considered a possibility. It is estimated that a total of 5km will require remedial work, over the life of the Proposed Development, dependent on survey results. This could be achieved through jetting, or the placement or replacement of rock armour.

4.8.13 **Table 4-26** provides the maximum assessment assumptions for operational and maintenance activities for the Proposed Development.

Table 4-26 Maximum assessment assumptions and parameters for operational and maintenance activities

Assessment assumption or parameter	Maximum value (Parameters presented in bold text)
WTG maintenance	

Assessment assumption or parameter	Maximum value (Parameters presented in bold text)
Maximum number of full painting events - lifetime quantity	225 (1 full event every 10 years)
Maximum number of cleaning events (bird waste and marine growth removal) - lifetime quantity	13,500 (up to 5 cleaning events per WTG per year)
Major WTG component replacement	
Maximum number of exchange events – lifetime quantity	315 (assumes on average 3.5 events per WTG over the lifetime)
Footprint of seabed disturbance via jacking-up activities per exchange event	1,100m ² (assumes 1,000m ² from construction vessel plus 10%)
WTG access ladder replacement	
Maximum number of ladder replacement events - lifetime quantity	450 (assumes replacement every 5 years)
Maximum footprint of seabed disturbance if JUV required	1,100m ² (assumes 1,000m ² from construction vessel plus 10%)
WTG anode replacement	
Maximum number of anode replacement events - lifetime quantity	450 (assumes replacement every 5 years)
Maximum footprint of seabed disturbance if JUV required	1,100m ² (assumes 1,000m ² from construction vessel plus 10%)
WTG J-tube replacement or modification	
Maximum number of J-tube replacement events - lifetime quantity	180 (assumes 2 per WTG over lifetime)
Maximum footprint of seabed disturbance if JUV required	1,100m ² (assumes 1,000m ² from construction vessel plus 10%)
Offshore substation major component replacement	
Maximum number of full painting events - lifetime quantity	6 (1 full event every 10 years per platform)
Touch-up painting in addition to full painting events	27 (1 touch-up event every 3 years)

Assessment assumption or parameter	Maximum value (Parameters presented in bold text)
Maximum number of cleaning events (bird waste / and marine growth removal) - lifetime quantity	450 (up to 5 cleaning events per platform per year)
Maximum number of exchange events - lifetime quantity	27 (assumes 9 events per platform)
Maximum footprint of seabed disturbance if jack-up vessel required	1,100m ² (assumes 1,000m ² from construction vessel plus 10%)
Offshore platform access ladder replacement	
Maximum number of ladder replacement events - lifetime quantity	30 (assumes 3 platforms, 10 ladders per platform over lifetime)
Maximum footprint of seabed disturbance if jack-up vessel required	1,100m ² (assumes 1,000m ² from construction vessel plus 10%)
Offshore platform anode replacement	
Maximum number of anode replacement events - lifetime quantity	60 (assumes 4 legs on each of 3 platforms with replacement every 5 years)
Offshore platform J-Tube replacement	
Maximum number of J-Tube replacement events - lifetime quantity	60 (assumes 2 per J-Tube over lifetime)
Array cable remedial burial	
Maximum number of remedial burial events for array cable – lifetime quantity	18 (assumes 0.07 reburial events per 1km installed over lifetime, and maximum of 250km of array cables)
Maximum length of cable subject to jetting remediation re-burial per remedial burial event	2,000m (rock dumping will also be considered)
Maximum width of disturbed seabed per individual jetting event	10m
Maximum footprint of (temporary) seabed disturbance per individual jetting exercise (for cable remediation)	200,000m ²
Array cable repairs	

Assessment assumption or parameter	Maximum value (Parameters presented in bold text)
Maximum number of cable repairs - lifetime quantity	6
Maximum cable trench width	10m
Maximum length of cable pulled from trench repair event	600m
Maximum footprint of seabed disturbance per event	6,000m ²
Predicted duration of each cable repair event	3 months
Footprint of seabed disturbance via jacking-up activities for single cable repair event	2,200m ²
Array cable protection replacement	
Percentage of original cable protection requiring replacement	25%
Export cable remedial burial	
Maximum number of remedial burial events for export cables - lifetime quantity	3 events per cable (assumes 0.07 reburial events per 1km installed over lifetime)
Maximum length of cable subject to jetting remediation re-burial) per remedial burial event	2,000m
Maximum width of disturbed seabed per individual jetting event	10m
Maximum footprint of (temporary) seabed disturbance per individual jetting exercise (for cable remediation)	20,000m ²
Export cable repairs	
Maximum number of cable repairs - lifetime quantity	4
Maximum cable trench width	10m

Assessment assumption or parameter	Maximum value (Parameters presented in bold text)
Maximum length of cable pulled from trench per repair event	600m
Maximum footprint of seabed disturbance per event	6,000m ²
Predicted duration of each cable repair event	3 months
Footprint of seabed disturbance via jacking-up activities for single cable repair event	2,200m ²
Export cable protection replacement	
Percentage of original cable protection requiring replacement	25%

- 4.8.14 The scheduled maintenance of the WTGs and offshore substation assets will be carried out within the structures themselves on mechanical, electrical, control and instrumentation and structural components. All other maintenance with possible environmental considerations is outlined in **Table 4-26**. Routine maintenance may occur 365 days per year.

Operation and maintenance vessel numbers and typical type

- 4.8.15 **Graphic 4-25** shows a typical service vessel that will be used to transport operation and maintenance personnel to the offshore site.

Graphic 4-25 Typical crew transfer vessel which can carry 12 to 16 passengers and equipment.



4.8.16 **Table 4-27** provides the maximum assessment assumptions for the operation and maintenance vessels.

Table 4-27 Maximum offshore vessels and logistics assessment assumptions and parameters for operation and maintenance

Assessment assumption or parameter	Maximum value (Parameters presented in bold text)
Offshore operation and maintenance activities	
Operation and maintenance vessels – CTVs	6
Operation and maintenance vessels – SOVs	2
JUVs	4
Onshore facilities area – offices	2,500m ²
Onshore facilities area – workshop and warehouse	2,500m ²
Harbour facilities – quayside length	125m
Operational hours	24-hours, 7 days a week

Assessment assumption or parameter	Maximum value (Parameters presented in bold text)
Offshore operation and maintenance activities⁷	
Helicopter maintenance visits	For unplanned maintenance tasks when CTV access not possible – access by winching directly onto WTGs.
Offshore helipads	No helipads required.
Operating base	Brighton City Airport (Shoreham Airport)
Number of helicopter return trips required during operation and maintenance phase per year	120
Refuelling	Onshore base only
Jack-up WTG visits (per year)	10
Jack-up platform visits (per year)	9
Jack-up total trips (per year)	19
Crew vessels WTG visits (per year)	850
Operation and maintenance vessel peak quantities	
Large operation and maintenance vessels	3
Small operation and maintenance vessels e.g. CTV	6
Lift vessels	2
Cable maintenance vessels	2
Auxiliary vessels	8

Maintenance port and facilities

- 4.8.17 The maintenance port and facilities will be located in Sussex and it is assumed that all direct labour will be resident within the area. It is likely that the existing facilities at Newhaven Port will be utilised (and expanded where necessary) as the base for operations management of Rampion 2, as this will yield synergies and enable effective coordination with the existing operations team on Rampion 1.

⁷ A single visit comprises a return trip to and from Rampion 2 array area.

- 4.8.18 At this stage the possibility of a supplementary satellite or alternative facility (in addition to Newhaven) further west in Sussex has not been discounted. The decision on whether to use an additional facility will depend on factors such as the eventual westward extent of the offshore wind farm and whether it is beneficial to have crew boat(s) stationed here to service the most westward WTGs, with vessels from Newhaven servicing the central/eastern parts of the turbine array.

Onshore operation and maintenance

- 4.8.19 Maintenance of the onshore cable is expected to be minimal. During operation and maintenance, periodic testing of the cable is likely to be required (every two to five years). This will require access to the link boxes at defined inspection points along the onshore cable route. Unscheduled maintenance or emergency repair visits will typically involve attendance by up to three light vehicles, such as vans, in a day at any one location. The vehicles will gain access using existing field accesses and side accesses as shown on the **Onshore Works Plans** (Document Reference: 2.2.2) to reach the relevant sections of the onshore cable.
- 4.8.20 Infrequently, equipment may be required to be replaced, then the use of an occasional HGV may be utilised, depending on the nature of the repair. Subject to the location of the repair, a replaced cable will involve building a temporary access using trackway or another temporary access road type, excavating to confirm the cable fault location using excavation equipment and excavating the required length of cable to enate a double joint repair. The length of cable replacement will be subject to the failure location and will be several meters in length. The several metres of failed cable will be removed, a double joint repair made and an equivalent length replacement spare cable installed. Once complete, the ground and the access will be re-instated.
- 4.8.21 Monitoring of the onshore substation will be done remotely using CCTV technology and other remote monitoring equipment. The security fencing installed during construction will remain in place. Certain areas of the onshore substation will have permanent light fittings. However, these lights will only be used when required for unscheduled maintenance or emergency repair purposes.
- 4.8.22 Inspection and minor servicing may be required for the electrical plant, but it is anticipated that the substation will require minimal scheduled maintenance and operation activities.
- 4.8.23 The Bolney substation extension, unscheduled maintenance or emergency repair visits will typically involve a very small number of vehicles, typically light vans. Infrequently, equipment may be required to be replaced, then the use of an occasional HGV may be utilised, depending on the nature of the repair.
- 4.8.24 It is anticipated that a monthly inspection of the AIS / GIS infrastructure will be required. Maintenance of the building(s) is anticipated to be carried out annually, with maintenance of AIS / GIS being carried out during substation outage periods, typically every few years.
- 4.8.25 Lighting during operation and maintenance activities is expected to be minimal. External lighting will be directional and limited to essential security and safety requirements. External works will usually be scheduled during daylight hours. If night working is required, then portable directional task lighting will be deployed.

- 4.8.26 For the onshore cable between the Oakendene substation and Bolney substation, unscheduled maintenance or emergency repair visits will follow the same process as the onshore cable, which is described in paragraphs 4.8.19 and 4.8.20.
- 4.8.27 Lighting during onshore operation and maintenance activities is expected to be minimal. External lighting will be directional and limited to essential security and safety requirements. External works will usually be scheduled during daylight hours. If night working is required, then portable directional task lighting will be deployed.

4.9 Decommissioning

Offshore decommissioning

- 4.9.1 At the end of the operational lifetime of the Proposed Development, it is anticipated that all structures above the seabed will be completely removed. The decommissioning sequence will generally be the reverse of the construction sequence and involve similar types and numbers of vessels and equipment. The decommissioning duration of the offshore infrastructure may take the same amount of time as construction of the Proposed Development, up to four years, although this indicative timing may reduce.
- 4.9.2 The Energy Act (2004) requires that a decommissioning plan must be submitted to and approved by the relevant Secretary of State, a draft of which will be submitted prior to the construction of the Proposed Development. The decommissioning plan and programme will be updated during the Proposed Development's lifespan.
- 4.9.3 To take account of changing best practice and new technologies, the approach and methodologies employed at decommissioning will be compliant with the legislation and policy requirements at the time of decommissioning. In accordance with the requirements provided in the [draft DCO](#) (Document Reference: 3.1), a written decommissioning programme will be provided prior to works commencing.

Wind Turbine Generators (WTG)

- 4.9.4 It is intended that the entire wind turbine structure is fully removed from site in its main constituent parts of rotor assembly, nacelle and tower before being disassembled fully onshore. The removal of turbine components is likely to be a reversal of the installation process.
- 4.9.5 The general methodology for carrying this out is as follows:
- De-energize and isolate from Grid (may be undertaken in phases);
 - Mobilise suitable heavy lift vessel(s) to the wind farm location;
 - Cut turbine array cables adjacent to the substructures;
 - Remove rotor component parts;
 - Remove nacelle;
 - Remove turbine tower; and

- Transport all components to an onshore site at which they will be processed for reuse, recycling or disposal.

4.9.6 As the tower will be made of steel, most of this item will be able to be recycled. The nacelle contains a number of different components. Fluids from these components, such as cooling oil within the transformers will be removed and recycled. A significant amount of the components will be made of metal and these will be recycled. All other materials will be recycled if appropriate, or otherwise disposed of at a licenced site. The blades are typically made of composite materials which have previously been very difficult to recycle. However, turbine manufacturers have been investing significantly in being able to improve the recycling rates of blades so it is expected that a large proportion of the blades will be able to be recycled.

WTG Foundations

- 4.9.7 Where a steel piled solution has been used, it is unlikely that full pile remove from the seabed will be possible due to the depth of embedment needed to make the structure stable. These will therefore be cut at or below seabed, typically 1m below seabed to avoid having to excavate too far to enable this operation. Once cut from the piles, the foundation structure above the seabed will be removed by a heavy lift vessel and returned to an onshore location for steel recycling.
- 4.9.8 Where a suction bucket solution has been used, it may be possible to reverse the pressure differential in the suction bucket to allow the entire structure to be removed. If this is not possible, then a cutting approach will utilise similar to that assumed for the steel piled solution.
- 4.9.9 In all circumstances, depending on the weight of the final foundation structure, the foundation may be cut into more than one piece to enable safe lifting.
- 4.9.10 The general methodology for decommissioning of the wind turbine foundations is likely to be as follows:
- Operate cutting procedure at or below seabed;
 - Remove the foundation structure using a suitable lifting vessel, incorporating further cutting of the structure as appropriate;
 - Transport to onshore location for offloading/disposal;
 - Remove internal equipment and disassemble onshore; and
 - Components processed for reuse, recycling or disposal.

WTG Foundation Scour Protection

- 4.9.11 It is proposed that all WTG foundation scour protection is left in situ.

Offshore Array Cables

- 4.9.12 Although it is expected that most array and export cables will be left in situ in line with current UK Government approved practice, for the purposes of the EIA it has been assumed that all cables will be removed during decommissioning. Exposed

cables are more likely to be removed to ensure they do not become hazards to other users of the seabed. At this point in time, it cannot be accurately determined whether and which cables will be exposed at the time of decommissioning.

- 4.9.13 In the event that offshore cables are removed, it is likely that equipment similar to that which is used to install the cables could be used to reverse the burial process and expose them. Therefore, the area of seabed impacted during the removal of the offshore cables could be the same as the area impacted during the installation of the cables. Divers and/or remotely operated vehicles (ROVs) may be used to support the offshore cable removal vessels.
- 4.9.14 Depending on the depth of burial and the presence of cable protection material, material may need to be removed prior to the cable being pulled.
- 4.9.15 The general methodology for decommissioning of the array cables is likely to be as follows:
- Cut cable from wind turbine structure;
 - Dig down to the cable if buried deep or it is otherwise determined that the cable cannot be pulled up;
 - Apply further cuts along the path of the array cable, if necessary, particularly if it is a long section;
 - Pull the cable from the seabed onto the deck of the removal vessel;
 - Cut the cable on deck into manageable sections;
 - Transport to onshore location for offloading/disposal; and
 - Components processed for reuse, recycling or disposal.
- 4.9.16 The power cores are likely to be either aluminium or copper and so will be able to be recycled, along with any steel armouring and metal sheathing material. Other elements that could be recycled will depend on the design of the cable.

Array Cable Protection

- 4.9.17 It is proposed that any cable protection is left in situ.

Offshore Substation Foundations

- 4.9.18 Though they may be larger, the decommissioning of the offshore substation foundations will essentially follow the same method as for the wind turbine foundations.
- 4.9.19 Where a steel piled solution has been used, it is unlikely that full pile remove from the seabed will be possible due to the depth of embedment needed to make the structure stable. These will therefore be cut at or below seabed, typically 1m below seabed to avoid having to excavate too far to enable this operation. Once cut from the piles, the foundation structure above the seabed will be removed by a heavy lift vessel and returned to an onshore location for steel recycling.
- 4.9.20 Where a suction bucket solution has been used, it may be possible to reverse the pressure differential in the suction bucket to allow the entire structure to be

removed. If this is not possible, then a cutting approach will utilise similar to that assumed for the steel piled solution.

4.9.21 In all circumstances, depending on the weight of the final foundation structure, the foundation may be cut into more than one piece to enable safe lifting.

4.9.22 The general methodology for decommissioning of the wind turbine foundations is likely to be as follows:

- Operate cutting procedure at or below seabed;
- Remove the foundation structure using a suitable lifting vessel, incorporating further cutting of the structure as appropriate;
- Transport to onshore location for offloading/disposal;
- Remove internal equipment and disassemble onshore; and
- Components processed for reuse, recycling or disposal.

Substation Foundation Scour Protection

4.9.23 It is proposed that all wind offshore substation foundation scour protection is left in situ.

Export Cables

4.9.24 Export cables will be pulled from the seabed using a suitable vessel. Depending on the depth of burial and the presence of cable protection material, material may need to be removed prior to the cable being pulled. The export cable will be removed from the seaward side up to where the cable exits the ducts at the landfall.

4.9.25 The general methodology for decommissioning of the array cables is likely to be as follows:

- Cut cable from WTG structure.
- Dig down to the cable if buried deep or it is otherwise determined that the cable cannot be pulled up.
- Apply further cuts along the path of the export cable if necessary.
- Pull the cable from the seabed onto the deck of the removal vessel.
- Cut the cable on deck into manageable sections.
- Transport to onshore location for offloading/disposal.
- Components processed for reuse, recycling or disposal.

4.9.26 The power cores are likely to be either aluminium or copper and so will be able to be recycled, along with any steel armouring and metal sheathing material. Other elements that could be recycled will depend on the design of the cable.

Intertidal area

- 4.9.27 To minimise the environmental disturbance during offshore wind farm decommissioning the preferred option is to leave cables buried in place in the ground with the cable ends cut, sealed and securely buried as a precautionary measure. Alternatively, partial removal of the cable may be achieved by pulling the cables back out of the ducts. This may be preferred to recover and recycle the copper and/or aluminium and steel within them.

Vessel activities

- 4.9.28 Decommissioning is currently based on reverse installation and the assumptions about maximum number of vessels and helicopters and their movements is therefore the same as described for construction of the offshore wind farm in **Table 4-4**.

Onshore decommissioning

Onshore cable

- 4.9.29 It is anticipated that the onshore electrical cables will be left in-situ with ends cut, sealed and buried to minimise environmental effects associated with removal.
- 4.9.30 The structures of the jointing pits and link boxes will be removed only if it is feasible with minimal environmental disturbance or if their removal is required to return the land to its current agricultural use.

Onshore Substation - Oakendene Substation

- 4.9.31 The onshore substation may be used as a substation site after decommissioning of the Proposed Development or it may be upgraded for use by another offshore wind project. This will be subject to a separate planning application.
- 4.9.32 Should the onshore substation need to be decommissioned fully, however, the decommissioning works are likely to be undertaken in reverse to the sequence of construction works and involve similar levels of equipment. All relevant sites will be restored to their original states or made suitable for an alternative use. Further detail will be provided in the decommissioning plan.
- 4.9.33 The decommissioning duration of the onshore infrastructure may take the same amount of time as construction of the Proposed Development, up to four years, although this indicative timing may reduce.
- 4.9.34 In accordance with the requirements provided in the **draft DCO** (Document Reference: 3.1) an onshore decommissioning plan will be provided within six months of the cessation of commercial operation of the connection works.

National Grid Bolney Substation extension works

- 4.9.35 The extension to National Grid Bolney substation will be owned by National Grid and will form part of the UK transmission network. It may be used for repowers or new connections after decommissioning of the Proposed Development. If it is

decommissioned, the connection bays will be disconnected from the bars, disassembled on site and removed from the site by HGVs for recycling. If GIS bays are used, the steel-frame building housing the bays will be disassembled onsite, removed from the site by HGV and recycled. The foundation of the GIS building may be broken up and removed for disposal, in which case the ground level will be reinstated as appropriate. The extension area will be returned to its original state or made suitable for an alternative use.

4.10 Consultation and engagement

Responses to the Planning Inspectorate Scoping Opinion

4.10.1 **Table 4-28** sets out the comments received in Section 2.3 of the Planning Inspectorate's Scoping Opinion (Planning Inspectorate, 2020) relevant to the Proposed Development and how these have been addressed in this ES. Full details of the Planning Inspectorate's Scoping Opinion comments and responses are provided in [Appendix 5.2: Response to the Scoping Opinion, Volume 4](#) of the ES (Document Reference: 6.4.5.2). Regard has also been given to other stakeholder comments that were received in relation to the Scoping Report (RED, 2020).

Table 4-28 The Planning Inspectorate's Scoping Opinion (2020) responses relevant to the description of the Proposed Development

Reference	Scoping Opinion comment	How this is addressed in this ES
Para 2.3.1	<i>Description of the Proposed Development The ES should include the following: - A description of the Proposed Development comprising at least the information on the site, design, size and other relevant features of the development; and - A description of the location of the development and description of the physical characteristics of the whole development, including any requisite demolition works and the land-use requirements during construction and operation phases.</i>	A clear explanation of the Proposed Development presented in the ES is provided throughout this chapter (Chapter 4: The Proposed Development, Volume 2 of the ES (Document Reference: 6.2.4)). Land-use requirements are presented in this ES.
Para 2.3.2	<i>Paragraphs 2.3.50 – 2.3.56 of the Scoping Report provides some detail on operation and maintenance activities. The ES</i>	This ES chapter (Section 4.8) provides a description of the nature and scope of operation and maintenance

Reference	Scoping Opinion comment	How this is addressed in this ES
	<p><i>should provide a full description of the nature and scope of these activities, including the types of activity, their frequency, and how works will be carried out for both the onshore and offshore elements of the Proposed Development. This should include consideration for the potential overlapping of activities with those required for the continuing operation of Rampion 1.</i></p>	<p>activities, including the types of activity, their frequency, and how works will be carried out for both the onshore and offshore elements of the Proposed Development. Any overlap of vessel activities between Rampion 1 and the Proposed Development will be mitigated and managed through the implementation of marine coordination for Rampion 2 project vessels (Chapter 13 Shipping and navigation, Volume 2 of the ES (Document Reference: 6.2.13)).</p>
Para 2.3.3	<p><i>Paragraph 2.3.56 and subsequent aspect sections of the Scoping Report address decommissioning in respect of the Proposed Development. The ES should include the rationale in support of the assessment of potential significant effects during the decommissioning phase, including a description of anticipated decommissioning activities (e.g. where the magnitude of impact is similar to that during construction). Where there is uncertainty of impacts during decommissioning this should be clearly explained along with the implications for the assessment of significant effects (including assumptions and mitigation on which reliance is placed). For example, there is reference to a “decommissioning plan” but production of such a document does not appear in the Applicant’s scoping commitments</i></p>	<p>This ES chapter (Section 4.9) provides a description of anticipated decommissioning activities.</p> <p>The effects arising during the decommissioning phase are assessed in aspect Chapters 6: Coastal processes to 29: Climate change, Volume 2 of the ES (Document Reference: 6.2.6 to 6.2.29).</p>

Reference	Scoping Opinion comment	How this is addressed in this ES
Para 2.3.4	<p><i>register (Scoping Report appendix 2).</i></p> <p><i>Offshore Inter-array cabling and offshore export cables are described as having a “Target depth” for burial of 1m (dependant on cable burial risk assessment). The cable burial risk assessment is recorded as commitment C-45 in appendix A of the Scoping Report, although it is not immediately clear whether this would take place prior to or post any DCO consent. The ES should be clear on the range of burial depths that have been considered as part of the assessment(s). Where reliance is placed on a subsequent risk assessment as mitigation, the ES should also explain the effectiveness and degree of confidence that can be placed on this measure.</i></p>	<p>This ES chapter describes the target burial depth, which will be dependent on cable burial risk assessment to be carried out when the cable route is finalised. This will be undertaken post-consent and will be secured through deemed marine licence conditions.</p>
Para 2.3.5	<p><i>The Scoping Report does not explain whether HVAC or Direct Current (HVDC) technologies are proposed, and the ES should describe the technology proposed or options sought in this regard. The Scoping Report also explains that array cables will be 33kV or 66kV but not the circumstances in which either 33kV or 66kV options would be chosen, or whether it might be a combination of both. The ES should describe these options, any differences in the physical infrastructure requirements and provide an assessment of environmental effects that may result between one or the other (or combined) option</i></p>	<p>This ES chapter describes that the array cables will be up to 132kV, dependent on the latest technology under development.</p> <p>Section 3.5 of Chapter 3: Alternatives, Volume 2 of the ES (Document Reference: 6.2.3) describes the selection process between HVAC and HVDC.</p>

Reference	Scoping Opinion comment	How this is addressed in this ES
Para 2.3.6	<p><i>The Inspectorate understands that preliminary engineering investigations indicate “several” design options for the WTG foundations could be considered including monopiles and jackets, and that “other solutions such as suction buckets may be used”. The ES should include a full and detailed description of all the foundation options for which development consent is being sought, including maximum diameter of piles should they be used. The Inspectorate makes further comments on flexibility in design in the following paragraphs.</i></p>	<p>This ES chapter (Section 4.3) describes all options under consideration for the WTG foundations and the maximum assessment assumptions.</p>
Para 2.3.7	<p><i>The Scoping Report identifies the potential need for seabed preparation for foundations and inter array cabling, which may include boulder and/or sandwave clearance. Any requisite seabed preparation for the export cable route should also be described and any resultant likely significant effects assessed within the ES. Should seabed preparation involve dredging, the ES should identify the quantities of dredged material and identify the likely location for disposal. The Applicant’s attention is drawn to the scoping consultation response of the MMO relating information required as part of the ES in supporting characterisation of new or existing disposal sites if they are to be included as part of the Proposed Development.</i></p>	<p>This ES chapter describes the seabed preparation activities, assessment assumptions for foundations and inter-array cabling. The effects arising from seabed preparation activities for foundations and inter-array cabling are assessed in relevant Chapters 6: Coastal processes to 18: Landscape and visual impact, Volume 2 of the ES (Document Reference: 6.2.6 to 6.2.18).</p> <p>Site characterisation of new or existing disposal sites has been undertaken in support of the application for development consent, see Site Characterisation Report (Document Reference: 5.2), and identifies any requirements for a disposal site, in line with the Marine Management</p>

Reference	Scoping Opinion comment	How this is addressed in this ES
Para 2.3.8	<i>The ES should identify the worst-case footprint of seabed disturbance that would arise from all offshore construction activities, for example seabed clearance/preparation, and vessel jack up and anchoring. The maximum footprints of all permanent components should also be identified.</i>	<p>Organisation (MMO) scoping consultation response.</p> <p>This ES chapter (Section 4.3) identifies the worst-case footprint of seabed disturbance that will arise from all offshore construction activities.</p>
Para 2.3.9	<i>The Scoping Report states that the construction of the landfall is “anticipated” to be via a trenchless technique “such as” HDD. The Inspectorate notes that commitment C-4 of Scoping Report Appendix A states that a HDD technique “will” be used at the landfall location. No other trenchless or trenched techniques are presented. The ES should describe and assess the options considered in this regard and the assessment of alternatives should explain the reasons for the selected option(s).</i>	<p>This ES chapter (Section 4.4) describes the construction of the landfall and techniques to be adopted.</p> <p>Chapter 3: Alternatives, Volume 2 of the ES (Document Reference: 6.2.3) provides a description and assessment of the techniques considered for landfall.</p>
Para 2.3.10	<i>Onshore Paragraph 2.3.38 of the Scoping Report explains that, in addition to buried cabling, onshore cable installation methods such as HDD will be also be used as required to avoid or minimise potential effects where constraints are identified, including environmentally sensitive water course crossings, major roadways and railways. The ES should identify the locations and type of all such crossings. Where reliance is</i>	<p>Appendix 4.1: Crossings schedule, Volume 4 of the ES (Document Reference: 6.4.4.1) identifies the locations and types of all trenchless crossings and is cross-referenced in the ES where appropriate. This ES chapter (Chapter 4: The Proposed Development, Volume 2 of the ES (Document Reference: 6.2.4)) identifies the locations and types of all trenchless crossings. Where</p>

Reference	Scoping Opinion comment	How this is addressed in this ES
	<p><i>placed in the ES on the use of a specific method as mitigation, the Applicant should ensure that such commitments are appropriately defined and secured. The Inspectorate notes that commitment C – 18 of the Scoping Report Appendix A refers to a “Crossing Schedule” being produced, and this should be cross-referenced throughout the aspect chapters where special crossing types are relevant.</i></p>	<p>reliance is placed in the ES on the use of a specific method as mitigation, this will be secured through the DCO.</p>
Para 2.3.11	<p><i>Paragraph 2.3.45 of the Scoping Report explains that onshore cable construction may be phased and there is a possibility that the installation of all onshore cables may not occur in a single operation. It is also explained that haul roads, and any construction compounds will be removed, and reinstatement will take place on completion of the installation. The construction programme should be defined in the ES on the basis of a worst case in respect of phasing periods. The ES should identify where new access routes, either temporary or permanent, are required to access the onshore cable corridor and compounds, as well as the duration for which they will be required in light of phasing (eg how long they will need to be retained for in light of cable installation in multiple operations).</i></p>	<p>The construction programme defined in this ES chapter is based on a worst case, as per Requirement 10 of the draft Development Consent Order (Document Reference: 3.1). This ES chapter) identifies where new access routes, either temporary or permanent, are required to access the onshore cable corridor and construction compounds, as well as the duration for which they will be required in light of phasing (e.g. how long they will need to be retained for in light of cable installation in multiple operations).</p>
Para 2.3.12	<p><i>The Scoping Report identifies the need for joint bays and link boxes “at regular intervals along the route” to enable the cable installation and connection</i></p>	<p>JBs, FOC JBs and LBs are required at regular intervals along the route; this is dependent on onshore substation, cable route and</p>

Reference	Scoping Opinion comment	How this is addressed in this ES
	<p><i>process. Regular intervals are defined as 600 – 1,000m in C-19, Appendix A of the Scoping Report, although it does define whether their locations will be determined by the time the application is made. The Inspectorate anticipates this may not be the case. If uncertainty persists, the ES should identify a worst-case scenario for the number of jointing pits and link boxes that may be required, and their impact during both construction and operation. Where commitments are made at specific locations to mitigate any potential effects, these should be secured through the Code of Construction Practice (CoCP) (or equivalent) as referred to at paragraph 4.4.27 of the Scoping Report.</i></p>	<p>length, as described in this ES chapter (Paragraph 4.5.18). Any impacts associated with joint bays, FOC JBs and link boxes during construction and, operation and maintenance are identified and assessed in aspect Chapters 18: Landscape and visual impact to 29: Climate change, Volume 2 of the ES (Document Reference: 6.2.18 to 6.2.29). Where commitments are made at specific locations these are detailed through the Outline Code of Construction Practice (Document Reference: 7.2).</p>
Para 2.3.13	<p><i>For the avoidance of doubt, the Inspectorate understands that the connection of the new substation to the existing National Grid Bolney substation would be via underground cabling (as is implied but not expressly stated at paragraphs 2.3.34 - 2.3.48 of the Scoping Report). The Inspectorate expects the ES to provide greater clarity as to the necessary connection works between the new substation and the Bolney substation (up to 5km away). This is particularly important if / where construction and operation of the connection may be of a different form or type (e.g. overhead line) to the connection of the new substation to the landfall. In addition, paragraph 2.3.35 states that the</i></p>	<p>This ES chapter outlines the necessary extension works to the existing National Grid Bolney substation and works for the cable between the onshore substation and the existing National Grid Bolney substation.</p>

Reference	Scoping Opinion comment	How this is addressed in this ES
	<p><i>existing National Grid Bolney substation would require “underground cables and minor upgrades”, and it is unclear whether these works would be part of the Proposed Development (as associated development) or subject to separate consent by National Grid or another party. These matters should be clearly set out in the ES and likely significant effects should be assessed.</i></p>	
Para 2.3.17	<p><i>Flexibility The Inspectorate notes the Applicant’s desire to incorporate flexibility into their draft DCO (dDCO) and its intention to apply a ‘Rochdale Envelope’ approach for this purpose. Where the details of the Proposed Development cannot be defined precisely, the Applicant will apply a worst-case scenario, as set out in section 2.2 of the Scoping Report. The Inspectorate welcomes the reference to Planning Inspectorate (PINS) Advice Note nine ‘Using the ‘Rochdale Envelope’ in this regard.</i></p>	<p>The Rochdale Envelope approach has been applied where appropriate. Where applied, a maximum design scenario will be adopted. Assessment assumptions associated with the maximum design scenario are provided throughout this chapter and Chapters 6: Coastal processes to 29: Climate change, Volume 2, of the ES (Document Reference: 6.2.6 to 6.2.29). The Planning Inspectorate Advice Note Nine ‘Using the Rochdale Envelope’ (Planning Inspectorate, 2018) has been adhered to.</p>
Para 2.3.18	<p><i>The Applicant should make every attempt to narrow the range of options and explain clearly in the ES which elements of the Proposed Development have yet to be finalised and provide the reasons. At the time of application, any Proposed Development parameters should not be so wide-ranging as to represent effectively different developments. The development parameters will need to be</i></p>	<p>Chapter 3: Alternatives, Volume 2 of the ES (Document Reference: 6.2.3) provides a narrative on how options considered for the Proposed Development have been refined and narrowed during the iterative design process. A summary of the refinement of the design of the Proposed Development between PEIR (RED, 2021) and ES is provided in</p>

Reference	Scoping Opinion comment	How this is addressed in this ES
Para 3.3.11	<p><i>clearly defined in the DCO and in the accompanying ES. It is a matter for the Applicant, in preparing an ES, to consider whether it is possible to robustly assess a range of impacts resulting from a large number of undecided parameters. The description of the Proposed Development in the ES must not be so wide that it is insufficiently certain to comply with the requirements of Regulation 14 of the EIA Regulations. In this regard, the Inspectorate expects that the component parameters presented in tables 2.2 and 2.3 of the Scoping Report will be refined and further detailed as part of the ES.</i></p> <p><i>The Inspectorate understands that the maximum height to blade tip of the Proposed Development's WTGs is 325m, whereas those installed as part of Rampion 1 are 140m to blade tip. This is likely to be a key consideration across the aspect chapters of the ES (particularly landscape and visual, cultural heritage and socio-economics), and the ES should be clear as how the magnitudes of effects of the Proposed Development (within the design envelope) account for the relationship with the Rampion 1 project</i></p>	<p>Section 4.1. Assessment assumptions are provided in this chapter and presented with assumption and parameters tables. Parameters have been presented in bold within these tables and provided separately in Appendix 4.3: Proposed Development Parameters, Volume 4 of the ES (Document Reference: 6.4.4.3).</p> <p>The preliminary assessment of effects of the WTGs in relation to landscape and visual impact, cultural heritage and socio-economics, are set out in Chapter 15: Seascape, landscape and visual impact assessment, Volume 2 of the ES (Document Reference: 6.2.15), Chapter 18: Landscape and visual impact, Volume 2 of the ES (Document Reference: 6.2.18), Chapter 25: Historic environment, Volume 2 of the ES (Document Reference: 6.2.25) and Chapter 17: Socio-economics, Volume 2 of the ES (Document Reference: 6.2.17). Details of the assessment assumptions and parameters are set out in this chapter</p>

Reference	Scoping Opinion comment	How this is addressed in this ES
Para 3.3.13	<p><i>As set out in paragraph 2.3.11 of this Scoping Opinion, the ES should be clear as to the potential construction programme options where the installation of all onshore cables may not occur in a single operation. Paragraph 4.4.26 and Figure 2.7 of the Scoping Report states that the construction of the Proposed Development will have a duration of approximately 5 years although it does not clearly state how this accounts for flexibility in the onshore construction programme and whether this accounts one or more cable installation operations.</i></p>	<p>and presented with assumption and parameters tables. Parameters have been presented in bold within these tables and provided separately in Appendix 4.3: Proposed Development Parameters, Volume 4 of the ES (Document Reference: 6.4.4.3).</p> <p>An outline construction programme is presented and described in this chapter (Section 4.7).</p>
Para 3.3.14	<p><i>Residues and Emissions</i> <i>The EIA Regulations require an estimate, by type and quantity, of expected residues and emissions. Specific reference should be made to water, air, soil and subsoil pollution, noise, vibration, light, heat, radiation and quantities and types of waste produced during the construction and operation phases, where relevant. This information should be provided in a clear and consistent fashion</i></p>	<p>Information on anticipated emissions from the Proposed Development is provided in this chapter (Chapter 4) and relevant aspect chapters (Chapters 6: Coastal processes to 29: Climate change, Volume 2 of the ES (Document Reference: 6.2.6 to 6.2.29)). An Outline Site Waste Management Plan (Document Reference: 7.3) is submitted alongside the</p>

Reference	Scoping Opinion comment	How this is addressed in this ES
	<i>and may be integrated into the relevant aspect assessments.</i>	application for development consent.
Para 4.4.5	<i>It is not yet confirmed which method of cable protection will be adopted for the proposed development, though it is noted that cable burial is the preferred option. The ES should explain the types of cable protection which could be used, and the associated impacts upon benthic subtidal and intertidal ecology.</i>	<p>The exact form of offshore cable protection to be used will depend upon local ground conditions, hydrodynamic regime/processes, and the selected cable protection contractor. However, the final choice will include one or more of the following:</p> <ol style="list-style-type: none"> 1. concrete ‘mattresses’; 2. rock placement; 3. geotextile bags filled with stone, rock or gravel; 4. polyethylene or steel pipe half shells, or sheathes; and 5. bags of grout, concrete, or another substance that cures hard over time. <p>This is described in this chapter (Paragraph 4.3.68).</p> <p>The impacts of introduced artificial substrates have been addressed in Section 9.10, Chapter 9: Benthic, subtidal and intertidal ecology, Volume 2 of the ES (Document Reference: 6.2.9) using available literature and a worst-case scenario to undertake a precautionary assessment.</p>
Para 5.1.11	<i>The Scoping Report states that up to 4 trenches will be required for the installation of the onshore corridor. The ES should report</i>	This chapter (Section 4.5) provides a full description of the onshore cable corridor, and Table 4-19 provides a

Reference	Scoping Opinion comment	How this is addressed in this ES
	<p><i>the number of trenches to be used and also dimensions of each and how long they would remain open for. The intention is to use trenchless techniques where possible; the ES should assess the landscape effects which may be created by open trenches.</i></p>	<p>summary of the assessment assumptions used in the EIA.</p> <p>Effects on landscape character/ elements as a result of the installation of the onshore cable corridor are assessed in Appendix 18.3: Landscape assessment, Volume 4 of the ES (Document Reference: 6.4.18.3) and summarised in Section 18.9 of Chapter 18: Landscape and visual impacts, Volume 2 of the ES (Document Reference: 6.2.18).</p>
Para 5.6.3	<p><i>The Scoping Report has scoped out potential impact on local roads, PRow and the users of these routes during decommissioning works on the basis that the effects of decommissioning will be lower than construction. The Inspectorate is unable to agree that this can be scoped out at this stage as the effects and subsequent mitigation have not been quantified for the construction phase. Although the transport impacts during decommissioning works would be similar or potentially lower than during construction, the ES should assess these matters where significant effects are likely to occur.</i></p>	<p>Acknowledged. It is proposed that all onshore and offshore subsurface cable infrastructure will be left in situ as part of the decommissioning phase (outlined in this chapter Section 4.9). Decommissioning effects will relate only to the removal of the onshore substation and traffic generation will therefore be lower than during construction. An assessment of the decommissioning effects of the onshore substation is included in Section 23.12, Chapter 23: Transport, Volume 2 of the ES (Document Reference: 6.2.23).</p>

Statutory Consultation

First Statutory Consultation exercise (2021 and reopened 2022): PEIR (RED, 2021)

- 4.10.2 In July 2021, RED published the PEIR (RED, 2021) in line with the requirements of Regulation 12 of the Infrastructure Planning (Environmental Impact Assessment) Regulations 2017 (hereafter referred to as the 'EIA Regulations 2017'). The EIA Regulations 2017 requires the Applicant to consult on 'preliminary environmental information' (where the proposed development is 'EIA development'), which is information that is reasonably required for the consultation bodies to develop an informed view of the likely significant environmental effects of the development (and of any associated development). Chapter 4: The Proposed Development, Volume 2 of the PEIR (RED, 2021) therefore set out the preliminary environmental information in respect of the Proposed Development and assessment findings of the EIA based on the available information at the time of publication.

Second Statutory Consultation exercise (2022): PEIR Supplementary Information Report (SIR) (RED, 2022)

- 4.10.3 The PEIR SIR (RED, 2022) was prepared to inform a second Statutory Consultation exercise (focused on the onshore parts of the Proposed Development only), which was held from 18 October 2022 to 29 November 2022, for a period of six weeks (RED, 2022). This provided supplementary environmental information associated with new alternatives and modifications to the Rampion 2 onshore part of the original PEIR Assessment Boundary. These design iterations were generated as a result of stakeholder consultation, including Statutory Consultation, engagement with landowners, and further engineering and environmental studies which had taken place since the publication of the PEIR in July 2021 (RED, 2021).

Third Statutory Consultation exercise (2023): PEIR Further Supplementary Information Report (FSIR) (RED, 2023a)

- 4.10.4 The PEIR FSIR (RED, 2023) was prepared to inform a third Statutory Consultation exercise (focused on a further single onshore cable route alternative), which was held from 24 February 2023 to 27 March 2023, for a period of four weeks (RED, 2023). The PEIR FSIR provided supplementary environmental information associated with the new proposed alternative to the Rampion 2 onshore part of the original PEIR Assessment Boundary. The proposed new alternative was identified in response to consultation feedback received since the publication of the PEIR SIR in October 2022 (RED, 2022).

Fourth Statutory Consultation exercise (2023): Preliminary Environmental Information (PEI) – Bolney Substation Extension Works (RED, 2023b)

- 4.10.5 The fourth targeted Statutory consultation exercise was held from 28 April to 30 May 2023 to allow representations to be made in respect of the proposed extension to and additional infrastructure at the existing National Grid substation at Bolney. The PEI (RED 2023b) was prepared to support the fourth targeted Statutory Consultation exercise and provided further supplementary environmental information associated with the proposed extension works to the existing National

Grid Bolney substation that fell within the original PEIR Assessment Boundary (RED, 2021).

- 4.10.6 A summary of the key themes of the feedback received in relation to the Proposed Development from both Statutory Consultation and non-statutory consultation exercises is provided in **Section 3.10** of **Chapter 3: Alternatives, Volume 2** (Document Reference: 6.2.3). A summary of all comments received during the formal consultation period and the response to those comments is provided in the **Consultation Report** (Document Reference: 5.1).
- 4.10.7 Non-statutory consultation has taken place at various stages throughout the Project, where appropriate, by the environmental aspects. The relevant engagement has been recorded through meeting minutes and tracked accordingly.

Page intentionally blank

4.11 Glossary of terms and abbreviations

Table 4-29 Glossary of terms and abbreviations

Term (Acronym)	Definition
Areas of temporary land use	Areas of land to be temporarily used throughout the construction phase of the Proposed Development. Following the construction phase, there is no permanent land requirement in these areas.
Array cables	Cables connecting the WTGs to each other and to the offshore substation(s).
Aspect	Used to refer to the individual environmental topics.
Cable circuit	A collection of conductors necessary to transmit electric power between two points. For High Voltage Alternating Current, this consists of three conductors (or a multiple of three).
CBS	Cement Bound Sand
Chartered Institute of Building Service Engineers (CIBSE)	CIBSE is the professional body advancing the art, science and practice of building services engineering.
CTV	Crew transfer vessel
DCO Application	An application for consent under the Planning Act 2008 to undertake a Nationally Significant Infrastructure Project made to the Planning Inspectorate who will consider the application and make a recommendation to the Secretary of State, who will decide on whether development consent should be granted for the Proposed Development.
Decommissioning	The period during which a development and its associated processes are withdrawn from service.
Development Consent Order (DCO)	This is the means of obtaining permission for developments categorised as Nationally Significant Infrastructure Projects, under the Planning Act 2008.
Embedded environmental measures	Equate to 'primary environmental measures' as defined by Institute of Environmental Management and Assessment (2016). They are measures to avoid or reduce potential impacts and subsequent effects that are

Term (Acronym)	Definition
	directly incorporated into the design of the Proposed Development.
Environmental Impact Assessment (EIA)	The process of evaluating the likely significant environmental effects of a proposed project or development over and above the existing circumstances (or 'baseline').
Environmental Statement (ES)	The written output presenting the full findings of the Environmental Impact Assessment.
FOC	Fibre Optic Cable
FOCJB	Fibre Optic Cable Joint Box
Geophysical	Relating to the study of physics of the earth. This is connected with the study of physical processes occurring within rocks and other substances.
HAT	Highest Astronomical Tide
HeRA	Helicopter Refuge Area
High Density Polyethylene (HDPE)	A hydrocarbon polymer known for its durability and tensile properties.
HGV	Heavy Goods Vehicles
High Density Polyethylene (HDPE) duct	A duct used to house copper and fibre optic cables installed using traditional pulling techniques.
Horizontal Directional Drill (HDD)	A trenchless crossing engineering technique using a drill steered underground without the requirement for open trenches. This technique is often employed when crossing environmentally sensitive areas, major water courses and highways. This method is able to carry out the underground installation of pipes and cables with minimal surface disruption.
HSSE	Health, Safety, Security and Environment
HV	High Voltage
HVAC	High Voltage Alternating Current
HVDC	High Voltage Direct Current

Term (Acronym)	Definition
Institute of Environmental Management and Assessment (IEMA)	International membership organisation for environment and sustainability professionals.
Impact	The changes resulting from an action.
Inshore	The sea up to two miles from the coast.
Intertidal	The area of the shoreline which is covered at high tide and uncovered at low tide.
Iterative design	A process by which the design is repeatedly improved to solve problems, respond to environmental measures and engage local communities and statutory stakeholders.
JB	Cable Joint Bays
JUV	Jack-up vessel
Land cover	The surface cover of the land usually expressed in terms of vegetation cover or lack of it. Related to but not the same as land use.
Landfall	The area between the transition pit and the mean low water springs tide line (MLWS).
LAT	Lowest Astronomical Tide
Likely significant effects	It is a requirement of Environmental Impact Assessment Regulations to determine the likely significant effects of the Proposed Development on the environment which should relate to the level of an effect and the type of effect.
Link box (LB)	Underground chambers adjacent to the cable trench containing low voltage electrical earthing links.
Marine aggregate	Marine dredged sand and/or gravel.
Maximum Design Scenario (MDS)	The maximum design scenario represents the worst-case scenario for each aspect whilst allowing the flexibility to make improvements in the future in ways that cannot be predicted at the time of submission of the DCO Application.
MCA	Marine and Coastguard Agency
MHWS	Mean High Water Springs

Term (Acronym)	Definition
MLWS	Mean Low Water Springs
MMO	Marine Management Organisation
National Grid Substation	Infrastructure where overhead power lines or underground cables are connected and electricity is transformed for distribution to the local area via the National Grid.
Nationally Significant Infrastructure Project (NSIP)	Nationally Significant Infrastructure Projects are major infrastructure developments in England and Wales which are consented by DCO. These include proposals for offshore wind farms with an installed capacity over 100MW.
Noise sensitive receptors	Locations or receptors that may potentially be adversely affected by the addition of a new source of noise. These can include residential properties, people and sensitive species.
Offshore	The offshore elements of the Proposed Development refer to works seaward of Mean High Water Springs (MHWS).
Onshore	The onshore elements of the Proposed development refer to works landward of the Mean High Water Springs (MHWS).
Offshore array area	The offshore area within which wind turbine generators and offshore platforms and associated cables will be located
Offshore export cable	Cables that transfer power from the offshore substation(s) to shore.
Offshore part of the DCO Order limits	An area that encompasses all planned offshore infrastructure and relevant buffer areas.
Offshore substation	Housing for the electrical components needed to transform power supplied by the WTGs. An export cable connects the offshore substation and the transition joint bay at landfall.
Offshore Wind Farm	A group of WTGs located offshore.
Onshore export cable	Cables that transfer power from the offshore export cables to the onshore substation(s).

Term (Acronym)	Definition
Onshore part of the DCO Order Limits	An area that encompasses all planned onshore infrastructure.
Onshore substation	A compound housing electrical equipment enabling connection to the National Grid. The onshore substation also contains equipment to help maintain stable grid voltage.
Planning Act 2008	The legislative framework for the process of approving major new infrastructure projects.
Planning Inspectorate	The Planning Inspectorate is the government agency supervising the planning process for NSIPs under the Planning Act 2008. The purpose of the Planning Inspectorate is to provide Expertise on planning appeals, national infrastructure planning applications, examinations of local plans and other planning-related and specialist casework in England and Wales.
PLGR	Pre-Lay Grapnel Run
Pre-lay plough	Offshore cable laying construction equipment.
Preliminary Environmental Information Report (PEIR)	The written output of the Preliminary Environmental Impact Assessment undertaken for the Proposed Development. It was developed to support Statutory Consultation and presented the preliminary findings of the assessment to allow an informed view to be developed of the Proposed Development, the assessment approach that was undertaken, and the preliminary conclusions on the likely significant effects of the Proposed Development and environmental measures proposed.
Preliminary Environmental Information Report Supplementary Information Report (PEIR SIR)	<p>The PEIR SIR was prepared to inform the second Statutory Consultation exercise held between 18 October 2022 to 19 November 2022.</p> <p>The PEIR SIR provided supplementary environmental information associated with further alternatives onshore routing options and modifications as a result of design evolution from the consultation process. The PEIR SIR is to be read in conjunction with the PEIR.</p>
Preliminary Environmental Information Report Further Supplementary Information Report (PEIR FSIR)	The PEIR Further Supplementary Information Report (FSIR) identified and provided further preliminary environmental information associated with the proposed alternative route option identified since the publication of the original PEIR and PEIR SIR in July 2021 and October 2022 respectively (RED, 2021; 2022).

Term (Acronym)	Definition
Preliminary Environmental Information (PEI)	Preliminary Environmental Information – Bolney Substation Extension Works identified and provides further preliminary environmental information associated with the proposed Bolney substation extension works identified since the publication of the original PEIR, PEIR SIR, and PEIR FSIR in July 2021, October 2022, and February 2023 respectively (RED, 2021; 2022; 2023).
Proposed Development	The development that is subject to the application for development consent, as described in Chapter 4: The Proposed Development, Volume 2 of the ES (Document Reference: 6.2.4).
Receptor	These are as defined in Regulation 5(2) of The Infrastructure Planning (Environmental Impact Assessment) Regulations 2017 and include population and human health, biodiversity, land, soil, water, air, climate, material assets, cultural heritage and landscape that may be at risk from exposure to direct or indirect impacts as a result of the Proposed Development.
RED	Rampion Extension Development Limited (The Applicant)
Rochdale Envelope	The Rochdale Envelope is a parameter-based approach to environmental assessment which aims to take account of the need for flexibility in the evolution of detailed design (Planning Inspectorate, 2018).
ROV	Remotely Operated Vehicle
RPM	Revolutions Per Minute
SCADA	Supervisory Control and Data Acquisition
Scour	A localised sediment erosion feature caused by local enhancement of flow speed and turbulence due to interaction with an obstacle.
Secretary of State (SoS)	The Minister for Department for Energy Security and Net Zero (DESNZ).
Scoping Opinion	A Scoping Opinion is adopted by the Secretary of State for a Proposed Development.
Scoping Report	A report provided to the Secretary of State by the Applicant that presents the findings of an initial stage in the Environmental Impact Assessment process. The Scoping Report should contain details on the Proposed

Term (Acronym)	Definition
	Development with a description of environmental issues and potential impacts.
Stakeholder	Person or organisation with a specific interest (commercial, professional or personal) in a particular issue.
Subsea grab	General term for all subtidal benthic grab sampling equipment used for sediment and faunal sampling such as a Day Grab.
Subtidal	The region of shallow waters which are below the level of low tide.
The Applicant	Rampion Extension Development Limited
THSD	Trailing hopper suction dredging
Transition Joint Bay (TJB)	A buried chamber where the offshore cables are jointed to the onshore cables.
Transpooling	The process of spooling flexible cables or pipes from one storage system to another.
Unexploded Ordnance (UXO)	Unexploded ordnance are explosive weapons (bombs, shells, grenades, land mines, naval mines, etc.) that did not explode when they were deployed and still pose a risk of detonation, potentially many decades after they were used or discarded.
Wind Turbine Generators (WTGs)	The components of a wind turbine, including the tower, nacelle, and rotor.
XLPE	Cross Linked Polyethylene

Page intentionally blank

4.12 References

- Brighton Boat, (n.d.). *Rampion Offshore Windfarm Construction*. [Online] Available at: <https://brightonboat.co.uk/nggallery/rampion-offshore-windfarm-construction/> [Accessed: 19 August 2021].
- British Standards Institution (BSI), (2014). *British Standard (BS) EN 12464-2:2014 Light and lighting - Lighting of work places. Part 2: Outdoor work places*. London, UK.
- Chartered Institution of Building Services Engineers (CIBSE), (2018). *Lighting Guide 1: The Industrial Environment*. CIBSE, England.
- Chartered Institute of Building Services Engineers (CIBSE), (2016) *Lighting Guide 6: The Exterior Environment*. CIBSE, England.
- Department of Energy and Climate Change (DECC), (2011). *National Policy Statement for Renewable Energy Infrastructure (EN-3)*. [Online] Available at: https://assets.publishing.service.gov.uk/government/uploads/system/uploads/attachment_data/file/47856/1940-nps-renewable-energy-en3.pdf [Accessed: 10 July 2023].
- Department for Energy Security and Net Zero (DESNZ), (2023). *DRAFT National Policy Statement for Renewable Energy Infrastructure (EN-3)*. [Online] Available at: https://assets.publishing.service.gov.uk/government/uploads/system/uploads/attachment_data/file/1147382/NPS_EN-3.pdf [Accessed 10 July 2023].
- Energy Networks Association (ENA), (2018). *TS 12-23 Polyethylene warning tape, polyethylene protection tape and polyethylene protection tiles for buried electricity supply cable. Issue 4*. Energy Networks Association. London, UK.
- Institute of Lighting Professionals, (2021). *Guidance Note 1 for the Reduction of Obtrusive Light*. [Online] Available at: <https://theilp.org.uk/publication/guidance-note-1-for-the-reduction-of-obtrusive-light-2021/> [Accessed: 10 July 2023].
- Planning Act 2008*, (2008). [Online] <https://www.legislation.gov.uk/ukpga/2008/29/introduction> [Accessed: 10 July 2023].
- Planning Inspectorate, (2018). *Advice Note Nine: Rochdale Envelope (Version 3)*. [Online] Available at: <https://infrastructure.planninginspectorate.gov.uk/legislation-and-advice/advice-notes/advice-note-nine-rochdale-envelope/> [Accessed: 10 July 2023].
- Planning Inspectorate, (2020). *Scoping Opinion: Proposed Rampion 2 Offshore Wind Farm Case Reference: EN010117*. [Online] Available at: <https://infrastructure.planninginspectorate.gov.uk/wp-content/ipc/uploads/projects/EN010117/EN010117-000045-EN010117%20Scoping%20Opinion.pdf> [Accessed: 10 July 2023].
- Rampion Extension Development Limited (RED), (2020). *Rampion 2 Offshore Wind Farm – Environmental Impact Assessment Scoping Report*. [Online] Available at: <https://infrastructure.planninginspectorate.gov.uk/wp-content/ipc/uploads/projects/EN010117/EN010117-000006-EN010117%20-%20Scoping%20Report.pdf> [Accessed: 10 July 2023].
- Rampion Extension Development Limited (RED), (2021). *Preliminary Environmental Information Report*. [Online] Available at: <https://rampion2.com/consultations-2021/> [Accessed 10 July 2023].

Rampion Extension Development Limited (RED), (2022). *Preliminary Environmental Information Report Supplementary Information Report*. [Online] Available at: <https://rampion2.com/consultation-2022/> [Accessed: 10 July 2023].

Rampion Extension Development Limited (RED), (2023a). *Preliminary Environmental Information Report Further Supplementary Information Report*. [Online] Available at: <https://rampion2.com/consultation-2023/consultation-2023-documents/> [Accessed: 10 July 2023].

Rampion Extension Development Limited (RED), (2023b). *Preliminary Environmental Information: Bolney Substation Extension Works*. [Online] Available at: <https://rampion2.com/consultation-2023-bolney/> [Accessed: 10 July 2023].

The Energy Act 2004, (2004). [Online] Available at: <https://www.legislation.gov.uk/ukpga/2004/20/contents> [Accessed 14 November 2022].

The Infrastructure Planning (Environmental Impact Assessment) Regulations 2017, (SI:572, 2017). [Online] <https://www.legislation.gov.uk/uksi/2017/572/made> [Accessed 14: November 2022].

Page intentionally blank

