

Appendix 30: Cambridgeshire County Council's Housing Estate Road Construction Specifications (HERCS)

Housing Estate Road Construction Specification

April 2018

cambridgeshire.gov.uk



HOUSING ESTATE ROAD CONSTRUCTION SPECIFICATION

April 2018 (amended August 2020)

<https://www.cambridgeshire.gov.uk/residents/travel-roads-and-parking/roads-and-pathways/highways-development/>

CONTENTS		Page No.
	Introduction	1
1.	Street Works Licences	3
2.	Third Party Insurance	3
3.	Inspection Regime	3
4.	Street Name Plates	4
5.	Temporary Signing Of New Housing Developments	5
6.	Definitions	5
	Construction Specification	
1.0	General Requirements	8
2.0	Design of Carriageway Construction	14
3.0	Construction and Earthworks Materials	15
4.0	Excavation and Filling	21
5.0	Backfilling Trenches	23
6.0	Weather Conditions	24
7.0	Preparation of Formation	26
8.0	Drainage of Sub-grade	27
9.0	Carriageway Foundation	28
10.0	Carriageway Base Layers	32
11.0	Carriageway Binder Course Layer	34
12.0	Carriageway Surface Course	36
13.0	Kerbs and Channels	42
14.0	Gully Grates and Frames	44
15.0	Gully Pots	46
16.0	Estate Road Highway Surface Water Drainage	47
17.0	Manhole Covers / Frames and Headwalls	52
18.0	Footways and Cycleways	53
19.0	Vehicular, Pedestrian and Cycle Crossings	57
20.0	Verges and Visibility Splays	59
21.0	Covers for Access to Utility Plant	61
22.0	Street Furniture	62
23.0	Completion of Works	64
24.0	Sampling of Materials	66
25.0	List of Contacts for Further Information	67
	List of Appendices	68

INTRODUCTION

1. Cambridgeshire County Council as Highway Authority is committed to adopting all residential estate roads under Section 38 of the Highways Act 1980 that serve a highway function, to five or more individual dwelling units and that have been constructed in accordance with this Construction Specification. Failure to comply with this construction specification will result in the road not being adopted by the Highway Authority. As part of the adoption procedure it is incumbent on all Developers to fully co-operate with all Highway Authority staff and Representatives.
2. Developers shall ensure that the engineering details are approved before work starts on site. This requires sufficient time to be allowed by the Developer from the granting of planning permission to the proposed start date. This is of particular importance if third parties (e.g. the Environment Agency) approvals are required. Works undertaken by the Developer without approved drawings will be wholly at their own risk and the Highway Authority reserves the right to require suitable testing of any such works to be undertaken at the cost of the Developer. The number, location and types of tests will be decided by the Highway Authority. If any of the tests fail the Highway Authority reserves the right to require that the development be reconstructed to this specification.
3. All costs associated with the technical approval of the works required for the proposed development must be undertaken at no cost to the Highway Authority.
4. The Developer is required to provide specific items of information as part of the engineering detail process. At a minimum these shall be:
 - a) A layout drawing showing the extent of the proposed adopted public highway shown in pink, proposed gully locations, connexions to the public surface water sewer and any highway drains are to be shown in blue. Any works within the existing adopted public highway shall be shown in green
 - b) A street lighting plan showing the locations of the proposed street lighting and proposed column and lantern types and design calculations
 - c) Long section drawings
 - d) Cross section drawings
 - e) General layout drawing
 - f) Construction drawings
 - g) A plan showing the areas drained by each gully. The areas drained will be identified by varying the direction of a simple 45⁰ line hatching. The plan shall show the areas drained by each gully in numbers and the direction and fall to the gully expressed as a factor of 1 (i.e. 1:150)

If the above information is not fully provided, no engineering detail approval will be given and adoption cannot take place.

5. To properly construct the new estate road, the Developer will have to work within the existing public highway. These works can form part of the Section 38 Agreement. However, if the Developer wishes to commence these works before the Section 38 Agreement is signed, they can be carried out under a Section 278 Agreement of the Highway Act 1980. Extra charges will be incurred as part of this process which must be fully borne by the Developer. No reduction in the Section 38 bond or fees will result if works relating to the Development are implemented under a Section 278 Agreement.
6. The Developer will ensure that a copy of this Construction Specification is on site at all times and is readily available to all ground workers, engineers or any other staff involved in the management, construction, detailing or the like in relationship to the construction of the proposed adopted public highway.
7. In matters concerning the construction, layout, design, compliance with this specification etc., in relationship to areas of proposed adopted public highway the decision of the Engineer is final.
8. It is recommended that the Developer contact the Engineer prior to any works commencing on site to arrange a meeting to discuss general working arrangements and any issues that may be specifically linked to the proposed development. Where this has occurred in the past it has been beneficial to both parties.

1. Street Works Licences

No work shall be carried out in the public highway without the prior approval of the Highway Authority. For any work that is carried out within the public highway, a licence must be obtained from:

Street Works and Permitting Manager
Cambridgeshire County Council, Vantage House, Washingley Rd, Huntingdon,
Cambridgeshire, PE29 6SR
Tel: 0345 045 5212 E-mail: street.works@cambridgeshire.gov.uk

The Developer is required to notify the Street Works and Permitting Manager of all works within the highway. The forms for street works notification, and the traffic lights form, should temporary traffic lights be required as part of the traffic management of your works, are available via the following link:

<http://www.cambridgeshire.gov.uk/highwaylicences>

In order to ensure there is no delay to your works commencing on site, please submit the forms at least six weeks before you propose to commence on site, to the Street Works Coordinator at the above address.

All licences and permissions must be issued before any work commences, and it is the responsibility of the Developer to apply for any licences that may be required well in advance. Working within the highway without the appropriate licences is illegal and the Highway Authority will, if required, take appropriate legal action against any Developer, who is found to be in breach of the Highways Act 1980.

2. Third Party Insurance

The Highway Authority shall not be held responsible for damage to property or apparatus where such damage arises as a consequence of the work associated with the estate road or any work within the existing highway.

It is the responsibility of the Developer to ensure that they and their Contractor(s) hold adequate third party liability insurance whilst working in the highway, any party undertaking such works must be able to demonstrate possession of valid insurance to the value of £10,000,000 for any one incident, number of incidents unlimited upon demand.

3. Inspection Regime

It will be the responsibility of the Developer to notify the Engineer at least five working days before any works to the proposed adopted public highway are to be undertaken, to enable a suitable level of inspection to be arranged. Works undertaken without suitable notification will be carried out wholly at the Developers risk and may be condemned by the Engineer.

The following list is a guide to the works that will require inspection and should therefore be notified to the Engineer, the list is not exhaustive:

- a) Surface water drainage – work to start inspection of drain run and trench backfill
- b) When any soil tests are undertaken in areas that are proposed to become part of the adopted public highway
- c) Formation – level, soft spots removed, and ready to receive sub-base
- d) Sub-base – sub-base material approval required and laying to commence – compliant test data and surface stiffness must be available prior to commencement of base/binder course installation
- e) Kerblines – kerbing to start and inspection of kerb beam and kerb line
- f) Base/Binder-course – start of work, inspection of compaction
- g) Street Lighting - planting of columns
- h) Footways/Cycleways – inspection of back edgings, formation, sub-base and Binder Course
- i) Carriageway Surface course – inspection of compaction and finished surface
- j) Footway/Cycleway Surface course – inspection of compaction and finished surface
- k) Sand bed and blockwork
- l) Inspection of the completed estate road to start maintenance period
- m) End of maintenance period - Final inspection prior to adoption

Additional non-notified inspections may also occur as and when the Engineer deems necessary.

The Engineer reserves the right to request cores of all carriageways, cycleways and footways at the Developer's expense before the surface course is laid in accordance with Clause 24.01.2 of this specification. The location and number of the cores will be at the discretion of the Engineer.

4. Street Name Plates

The District Council has the responsibility for street naming and numbering. Depending on the District Authority in which your development is located, you may be required to erect the street nameplates (once the District Authority has advised you of the name(s) chosen), or you may be required to pay the District Council to undertake the task. Please ensure that you consult the relevant District Council in good time to facilitate appropriate timeliness of the process.

5. Temporary Signing Of New Housing Developments

The Highway Authority will, in certain circumstances, permit developments to be temporarily signed. The proposed location of the signs must be approved by the Highway Authority prior to the installation of any such signing.

The signed route must start at the nearest Classified County Road (or Trunk Road) or other signed route which can be used to direct users of the highway to the site without the need for specific temporary signs.

The minimum size of development that the Highway Authority will allow signage on public highway for will be 10 separate dwelling units or 30 flats / apartments / maisonettes or the like.

The design of the temporary signing shall conform to Diagram 2701 and 2701.1 Schedule 13, Part 6 of The Traffic Signs Regulations and General Directions 2016. The signs shall be manufactured using a non-reflective material

The lowest edge of the signs must be set at least 2.45m above the surface of a footpath, footway or verge, at least 3.0m above the surface of a shared use path or cycleway and at least 5.4m above the surface of a carriageway over which they project.

All signs must be attached to existing street furniture. Where signs are proposed to be attached to street lighting columns the developer must contact Cambridgeshire's Street lighting. The Highway Authority will not permit the installation of new posts within the adopted public Highway for temporary signing.

The signing schedule shall form part of the approved drawings for any Section 38 Agreement and the provisional certificate for the site will not be issued until all the temporary signing has been removed.

If the proposed development is not to be offered for adoption, the Highway Authority reserves the right to impose what reasonable fees, charges and deposits it feels are necessary to control the use of temporary signing within the adopted public Highway.

Please note none of the above exempts the Developer from the possibility that Planning Permission may be required for the temporary signing and the Highway Authority suggests that the advice of the Local Planning Authority is sought on this matter by the Developer.

6. Definitions

The following list of words used in this document has the meanings ascribed to them below. These meanings relate to this document only.

California Bearing Ratio (CBR) – A value for comparing strengths of soils; in this specification the design CBR value is obtained from Table 2A - Design of CBR Values

Carriageway - the surfaced part of the road primarily designed for the use of all vehicle types

CASC – Cambridgeshire Asphalt Surface Course

Channel - Narrow strip, generally at the edge of the carriageway, designed to carry and lead away surface water

Cycleway – that part of the highway over which the public have a right of way by cycle

Developer - A person or group of person who are responsible for the construction, maintenance etc., of the site within which the proposed adopted public highway is to be built

Engineer – Executive Director – Place and Economy, their successor or their designated Representative

Footpath - A way over which the public have a right of way on foot only, not being a footway. A footpath will not be subjected to any possible vehicular overrun

Footway - that part of the highway, being a way over which the public have a right of way on foot only which is adjacent to a carriageway.

Formation - The level at which highway construction meets natural ground surface or the completed earthworks

Gully - a pot, generally trapped, constructed in the carriageway edge to drain water from the carriageway

HAPAS - The Highway Authorities Product Approval Scheme was set up by the Highways Agency, CSS and the British Board of Agrément, with the objective of developing national approval arrangements for innovative products, materials and systems for use in highways and related areas, removing the need for individual authorities to carry out their own assessments and tests

Highway - The highway comprises of the carriageway, cycleway and/or footway surface and any verges or visibility splays between the boundaries

Lightweight Deflectometer – test for measuring the foundation surface modulus stiffness value

Maintenance Strips – Highway Authority area behind kerbing for kerb maintenance

Manhole - A chamber and shaft constructed to enable access at intervals along highway drainage and/other service

Manual of Contract Documents for Highway Works, Volume 1 Specification for Highway Works (SHW) –The national specification for all construction and maintenance works on public highways. The Specification details all materials and

workmanship standards that must be met. This Cambridgeshire County Council Construction Specification clarifies the local interpretation of the SHW

Section 38 Agreement (S38) – An agreement between the County Council as Local Highway Authority and the Developer under Section 38 of the Highways Act 1980

Section 278 Agreement (S278) - An agreement between the County Council as Local Highway Authority and the Developer under Section 278 of the Highways Act 1980

Subgrade - Natural ground material at and below formation

Tree Preservation Order - A TPO is made by the local planning authority to protect specific trees or particular woodland from deliberate damage and destruction

CONSTRUCTION SPECIFICATION

1.0 GENERAL REQUIREMENTS

1.01 Design Considerations

1. Where a site may be liable to flood no finished highway level shall be lower than the adjacent minimum floor level of the dwellings approved by the relevant Authority. In addition it shall be no lower than the existing highway or otherwise from which access to the estate is gained, whichever is the lower.
2. The Highway Authority will not accept water from privately owned areas being collected by highway drainage.
3. Work shall not start on site until the Engineer has formally approved the Section 38 plans in writing. All Section 38 works shall be designed in accordance with this Specification.
4. All carriageways are to be cambered unless agreed in writing by the Engineer.
5. If the development is deemed to require an overland flood route in a exceedance event as part of its flood water mitigation strategy, then the permission to use any proposed adopted public highways for such a route must be gained prior to any submission for a Section 38 Agreement is made.
6. Where it is intended that the proposed adopted public highway shall form part of an overland water conveyance route during an exceedance event, the roads to be used as such must be constructed to a traditional format, i.e. with carriageway and footways with full faced kerbs, except where accesses to properties are to be provided. Such roads must be cambered in accordance with clause 1.04(1) of the Housing Estate Road Construction Specification. The use of shared surfaces as part of an overland flood exceedance route will not be permitted.
7. Where it is intended that the proposed adopted public highway shall form part of an overland water conveyance route, the roads to be used as such must have a continuous longitudinal fall of not less than 1:200 and shall contain no features such as speed tables etc., that will impede the free flow of the flood water.

1.02 Design of Construction Thickness

1. Carriageway construction alternatives are shown in Appendices 1, 2 and 3.
2. A ground investigation for the proposed development shall be provided along the centreline of the proposed highway before any construction works to the proposed adopted public highway commence. The CBR tests the Developer shall carry out are detailed below. The minimum information for road design purposes must include soil classifications and in-situ moisture contents produced from the logs of bore holes or trial pits.
 - a) For all sites soil tests shall be carried out at a minimum of two tests per road along the centreline of the proposed adopted public highway, the exact

number and frequency to be agreed by the Engineer prior to commencement. The initial test shall be positioned at the entrance to the proposed development and the final test shall be placed at the end of the 'road' to be offered for adoption.

- b) The required tests shall be taken at a depth of 500mm below the level of the proposed finished highway surface
 - c) On all sites the lowest CBR design value will be used to determine the construction depth (see Section 2). If the CBR design values are concentrated in particular locations the Engineer may consider permitting the use of localised excavation depths in correlation to the measured values
 - d) If the Developer fails to undertake a regime of testing as detailed above the Engineer will consider any other results to be insufficient to derive a suitable CBR value and the whole site will have to be designed using a value of less than 2%
3. Construction thickness is dependent on the equilibrium CBR values derived from the Plasticity Values from Table 2A - Design of CBR Values, at proposed formation level on the line of the road. The Developer shall determine these values and produce the required evidence with the preliminary plans submitted for approval.
4. Where derelict sites, landfill areas, soft ground, buried structures, etc., are a feature of the development area, special design measures may be necessary and the Engineer's approval for the detailed design must be sought and obtained by the Developer prior to starting the Highway works.
5. All sampling and testing shall be performed in accordance with relevant current British Standards (or equivalent). Where appropriate, all laboratory results shall be reported on UKAS certificates.

1.03 Junction Design - Requirement for Safety Audit

- 1. Designs for new junctions on the public highway may be subject to Safety Audit at Stages 1, 2, 3 and 4. Such Safety Audits shall be carried out by Cambridgeshire County Councils Road Safety Engineering Team, on a submitted detailed design and specification in accordance with the latest DMRB HD19/xx.
- 2. Applications for Section 38 Agreements for new roads incorporating junctions comprising right turn facilities, roundabouts or signals must be accompanied by a formal request for a Stage 2 Safety Audit to be carried out by Cambridgeshire County Councils Road Safety Engineering Team, together with an undertaking by the Developer to pay the reasonable costs of the Council in executing this work.
- 3. Any such costs are additional to the Agreement fee payable to the Council under the terms of the Section 38 Agreement and are payable within 21 days of the date of the final Safety Audit.

1.04 Mud etc., on the Highway

1. When any mud, clay or similar material has fallen or been deposited on a highway from a vehicle that has entered, left or serviced the development site it shall be removed from the highway completely, as soon as is reasonably practicable. The Developer's attention is drawn to Sections 148 and 149 of the Highways Act 1980.
2. The person in charge of any vehicle shall not bring the vehicle, or cause it to be brought upon a highway, unless there has been removed from the wheels thereof as completely as is reasonably practicable all mud, clay, lime or similar material which is likely if not so removed, to cause obstruction, nuisance or danger to persons using the highway, or injury to the surface of the highway.
3. In order to achieve acceptable low levels of carriageway contamination the Developer will install suitable wheel washing or pressure washing facilities, the cost of this installing and operating the wheel washing will be borne by the Developer.
4. Suitable approved warning signs must be exhibited whilst works are in progress.
5. The Developer shall also ensure that all highway drains and ditches, roadside grips and other drainage features, are kept clear of any spoil, mud, slurry or other material likely to impede the free flow of water therein. If instructed by a representative of the Highway Authority all highway drains and ditches, roadside grips and other drainage features, shall be cleaned and made to flow freely with all due haste.

1.05 Prohibition of use of the Highway

1. The existing public highway must not be used as site roads or sites for stockpiling and storing plant, materials or equipment. The Developer shall be liable for the cost of reinstatement if any damage has been caused to the highway.

1.06 Notification of Emergency Telephone numbers

1. The Developer shall erect and maintain for the duration of the construction of the estate roads, a board or sign, within the site boundary, but clearly visible from the adopted highway, indicating the name and contact telephone number of a responsible person for the site. The named person and contact telephone number shall be available 24 hours a day, seven days a week, should the Engineer need to advise the Developer and/or Contractor of a serious or dangerous situation.

1.07 Preliminary Site Works

1. Following the issue of a Street Works licence to place apparatus in the highway, the Engineer must be given a minimum of five working days notice of the start of the highway construction works to arrange a suitable regime of inspection and must be kept informed of the construction programme thereafter. Please note that on Traffic Sensitive routes at least 28 days notice is required before works may commence on site.
2. The work shall be carried out to the satisfaction of the Engineer, who shall have free access at all reasonable times to any part of the works.

3. During construction, the Developer may be required to prove the thickness and type of any material or layer if it has been covered prior to inspection - refer to clause 24.01.2 of this specification.
4. The estate roads and visibility splays shall be laid and set out in accordance with the approved plan and maintained in this form until the relevant physical works are complete.
5. The new estate road, where it joins the existing public highway, shall have its bellmouth, footways and visibility splays constructed to finished surfacing levels prior to any other works taking place on the site. The existing carriageway surfacing shall be cut back to a clean vertical edge and the development constructed up to that edge. The surface course shall be overlapped by 300mm with the vertical joint receiving hot applied 40-60 pen bitumen, as shown on Appendix 11 – Stepped Construction Detail.
6. In the construction of shared surfaces the Highway Authority encourages the Developer to use a sacrificial layer of a minimum of 80mm of bituminous base to provide a suitable running surface while permitting the installation of all connections to the public utility services that inevitably damage the bituminous construction of the highway. Such damage can lead to extensive and costly full depth reinstatements where a sacrificial layer has not been used.

1.08 Commuted Sums

1. The Highway Authority reserves the right to impose on a Developer a suitable commuted sum for extra costs associated with using materials within the proposed adopted public highway, that do not form part of this specification.
2. Commuted sums shall be calculated as detailed in the councils Highway Operational Standards, Appendix V - Highway Standards and Enforcement, updated annually, and following the principals of the CSS (ADEPT) publication 'Commuted Sums for Maintaining Infrastructure Assets' guidance document, available at the following link:

<http://www.adeptnet.org.uk/>
3. The Highway Authority will require a commuted sum for each soakaway due to the extra maintenance requirements of such drainage features. The commuted sum amount is published annually in the ETE Schedule of fees and charges, available on the authority's website.

1.09 General Construction Requirements

1. All materials and workmanship shall be in accordance with the appropriate British Standard/European Standard and SHW, current at the time of the appropriate S38 /S278 Agreement. All materials shall be kite-marked or produced within a defined quality assurance scheme unless otherwise approved by the Engineer.
2. The design of the works must be site specific.

3. Maintenance Strips are utilised on shared surface access roads. All maintenance strips shall be a minimum of 0.5m wide, and shall comprise of a paved surface. Utility easements may still be required in addition to the maintenance strips, these 0.5m strips shall not be used for the installation of services.
4. A sustainable approach to highway construction and the use of recycled products is encouraged. Such products should be utilised wherever it is possible to include them without compromising the quality of the finished works. Evidence of suitability for all recycled materials shall be provided to the Engineer prior to use. This approval process and any expansion of this specification will only be provided at the Developer's expense.

1.10 Surface Regularity and Tolerances

1. Surface Regularity - The regularity of the completed surfaces of estate road carriageways, cycleways and footways shall comply with the requirements of the following Table 1A.

Table 1A - Transverse and Longitudinal Straight Edge Measure

Highway Layer	Maximum deviation permitted under the appropriate straight edge
Surface Course Asphalt	Max 5mm under a 3m straight edge
Blockwork	Max 2mm difference in level between adjacent Blocks and max 6mm under a 3m straight edge
Footways & Cycleways	Max 3mm under a 1m straight edge

2. In addition, for estate road carriageways exceeding 40m in length and for lengths of cycleway, footway, footpath and shared surfaces exceeding 40m continuous length, without dropped kerbs intervening, then the following Table 1B shall also apply.

Table 1B - Longitudinal Rolling Straight Edge Measure

Irregularity	4mm	7mm	>10mm
Permitted max number of irregularities per 40m length	10	1	Nil
Permitted max number of irregularities per 75m length	18	2	Nil

3. At the discretion of the Engineer occasional trenches may be allowed. Cross trenches that are cut through any carriageway surface must be restored to coincide with the mean level of the immediately adjacent surface. All services must be installed prior to any asphalt being laid. Attention is drawn to the requirements of Section 5.0 - Backfilling Trenches and Appendix 11, Stepped Construction Detail.
4. The Developer shall set all fixed surface features, boxes and ironwork in the footway, cycleway or carriageway to coincide with the mean level of the immediately adjacent surface. Such fixing shall be done prior to the final wearing course.

5. Tolerances - The difference in level of a fixed surface feature and the immediately adjacent surface shall not exceed a tolerance of + or - 6mm except for those contained in Table 1C.

Table 1C – Tolerance for other fixed surface features

Kerb upstand	125mm +/- 5mm
Access way kerb upstand	25mm +/- 3mm
Vehicular crossing kerb upstand	25mm +/- 3mm
Pedestrian and Cycleway Crossing kerb upstand	6mm
Surface Adjacent to Gullies	-10mm to – 5mm
Surface Adjacent to PCC channels	+3mm to +6mm

6. For a Diagram of the Stepped Construction Detail, refer to Appendix 11.

2.0 DESIGN OF CARRIAGEWAY CONSTRUCTION

2.01 General

1. Appendices 1, 2 and 3 detail acceptable standard construction thickness for the permitted range of alternative base types and show the sub grades of various CBR's.
2. CBR values to be used for design are to be derived from plasticity index testing using samples from agreed appropriate depths and positions on site. Full test results including moisture content at test plasticity indices and materials classification must be submitted to support the claimed design CBR value, which shall be derived from Table 2A below.

Table 2A – Design of CBR Values

Soil Type	Plasticity Index from soil survey	Design CBR %
Plastic Clay	50 or greater	< 2
Silty Clay	40 - 49	2
Silty Clay	30 -39	3
Sandy Clay	20 – 29	3
Very Sandy Clay	10 - 19	4
Very Silty Clay	10 - 19	< 2
Silt	-	< 2
Sand (poorly Graded) (C.O.U. <10)	-	7
Sand (well graded) (C.O.U. >10)	-	10
Sandy Gravel (well graded) (C.O.U. >10)	-	15
Chalk	-	5

3. If Plasticity Index Values are not available from soil survey and test data for the proposed site, a CBR of less than 2 shall be assumed for the design.
4. A soil assessment cone penetrometer (MEXE probe) may be used for on-site checks for soft areas. Alternatively, if available vehicle mounted in-situ CBR testing equipment may be used.
5. The MEXE probe and other in-situ methods will not be acceptable for establishing the Design CBR values, only for locating areas where the in-situ values may be lower than the agreed Design CBR value.
6. The total carriageway way thickness shall be at least 490mm inclusive of sub-base.
7. Concrete Block Paving within the proposed adopted public highway is generally restricted to use on shared surface areas. Where used it must be installed with one of the base options and the required sub-base as detailed in Appendix 3.

3.0 CONSTRUCTION AND EARTHWORKS MATERIALS

3.01 General

1. All materials used in the works shall comply with the relevant current British Standard/EN Specification and/or the current edition of the SHW.
2. The materials shall be to the approval of the Engineer and samples shall be submitted for approval if required. Free access shall be granted to the Engineer's Representative for sampling during the course of the works. The Engineer may require independent testing of material at the Developers cost.

3.02 Definition, Classification and General Use of Earthworks Materials

1. The following definitions of earthworks materials shall apply to this and other Clauses of the Specification in which reference is made to defined materials.
 - a) 'topsoil' at the discretion of the Engineer the first 100mm of any grassed area may be considered topsoil otherwise all material from grassed areas and the like shall be deemed to be unacceptable material, this must conform to BS 3882:2007
 - b) 'suitable material' shall comprise all that which is acceptable in accordance with the Specification for use in the works
 - c) 'unsuitable material' shall mean other than suitable material
2. For the purpose of Table 3A - Earthworks Compaction as below, materials are grouped as follows
 - a) 'cohesive soil' includes clays and marls with up to 20% of gravel or rock and having moisture content not less than the level of the plastic limit (determined in accordance with BS 1377 Part 2:1990) -4; chalk having saturation moisture content of 20% or greater
 - b) 'well graded granular and dry cohesive soils' includes clays and marls with up to 20% of gravel or rock and having a moisture content not less than the level of the plastic limit (determined in accordance with BS 1377 Part 2:1990) -4, well graded sands and gravels with a uniformity coefficient exceeding 10 and chalk having a saturation moisture content of 15-20%
 - c) 'uniformly graded material' includes sand and gravels with a uniformity coefficient of 10 or less and all silts and pulverised fuel ashes. Any soil containing 80% or more of material in the particle size range 0.06mm – 0.002mm will be regarded as silt for this purpose

Table 3A – Earthworks Compaction

Type of Compaction Plant	Category	Cohesive Soils		Well Graded Granular and Dry Cohesive Soils		Uniformly Graded Material	
		D	N	D	N	D	N
Smooth wheeled Roller	Mass per meter width of roll Kg/m						
	Over 2100kg up to 2700kg	125	8	125	10	125	10
	Over 2700kg up to 5400kg	125	6	125	8	125	8
	Over 5400kg	150	4	150	8	Unsuitable	
Vibrating Roller	Mass per metre width of roll on a vibrating roller Kg/m						
			*		*		*
	Over 270kg up to 450kg	Unsuitable		75	16	150	16
	Over 450kg up to 700kg	Unsuitable		75	12	150	12
	Over 700kg up to 1300kg	100	12	125	10	150	6
	Over 1300kg up to 1800kg	125	8	150	8	200	10
	Over 1800kg up to 2300kg	150	4	150	4	225	12
	Over 2300kg up to 2900kg	175	4	175	4	250	10
	Over 2900kg up to 3600kg	200	4	200	4	275	8
	Over 3600kg up to 4300kg	225	4	225	4	300	8
	Over 4300kg up to 5000kg	250	4	250	4	300	6
	Over 5000kg	275	4	275	4	300	4
Vibrating Plate compactor	Mass per unit area of base plate Kg/sqm						
	Over 880kg up to 1100kg	Unsuitable		Unsuitable		75	6
	Over 1100kg up to 1200kg	Unsuitable		75	10	100	6
	Over 1200kg up to 1400kg	Unsuitable		75	6	150	6
	Over 1400kg up to 1800kg	100	6	125	6	150	4
	Over 1800kg up to 2100kg	150	6	150	5	200	4
	Over 2100kg	200	6	200	5	250	4
Vibro-Tamper	Mass						
	Over 50kg up to 65kg	100	3	100	3	150	3
	Over 65kg up to 75kg	125	3	125	3	200	3
	Over 75kg up to 100kg	150	3	150	3	225	3
	Over 100kg	225	3	200	3	225	3

D = Maximum depth of compacted layer N = Minimum number of passes

*** For twin-drum machines with both drums vibrating, halve the number of passes. If in doubt concerning machine-rating contact the Engineer**

3. The majority of small vibrating plate compactors do not comply with the minimum requirements of this table and are therefore not suitable of sub-base compaction.
4. Manufactures plant should be checked against the Type and Category columns to determine their suitability and performance and layer thickness.
5. The Developer shall only employ that plant which is suitable to the soils that are to be handled. The Developer shall take care to maintain the nature of the suitable material so that when it is placed and compacted it remains suitable in accordance with the Specification.
6. Any fill material used within 500mm of concrete structures or cement bound materials shall have a soluble sulphate content not exceeding 1.9g /lte when tested in accordance with clause 5 of BS1377-3, unless special precautions to the approval of the Engineer are taken to protect the concrete or cement bound materials.

7. Where the excavation reveals a combination of suitable and unsuitable materials the Developer is advised to carry out the excavation in such a manner that the suitable materials are excavated separately for use in the Works without contamination by the unsuitable materials.

3.03 Definition, Classification and General Use of Sub-base Materials

- Materials for use as sub-base shall comply with the requirements of Section 9.0 of this Specification.
- The compaction of sub-base materials shall meet the requirements of Table 3B - Sub-base Compaction, below.

Table 3B – Sub-base Compaction

Type of Compaction Plant	Category	Number of passes for layers not greater than:	
		110mm	150mm
Smooth wheeled Roller	Mass per meter width of roll Kg/m		
	Over 2700kg up to 5400kg Over 5400kg	16 8	Unsuitable 16
Vibrating Roller	Mass per metre width of roll on a vibrating roller Kg/m	*	*
	Over 700kg up to 1300kg	18	Unsuitable
	Over 1300kg up to 1800kg	6	16
	Over 1800kg up to 2300kg	4	6
	Over 2300kg up to 2900kg	3	5
	Over 2900kg up to 3600kg	3	5
	Over 3600kg up to 4300kg	2	4
	Over 4300kg up to 5000kg Over 5000kg	2 2	4 3
Vibrating Plate compactor	Mass per unit area of base plate Kg/sqm		
	Over 1400kg up to 1800kg	8	Unsuitable
	Over 1800kg up to 2100kg	5	8
	Over 2100kg	3	8
Vibro-Tamper	Mass kg		
	Over 50kg up to 65kg	4	8
	Over 65kg up to 75g	3	6
	Over 75g	2	4

* For twin-drum machines with both drums vibrating, halve the number of passes. If in doubt concerning machine-rating contact the Engineer

- The majority of small vibrating plate compactors do not comply with the minimum requirements of this table and are therefore not suitable of sub-base compaction.
- Manufactures plant should be checked against the Type and Category columns to determine their suitability and performance and layer thickness.

3.04 Definition, Classification and General Use of Trench Reinstatement Materials

1. For the purposes of Table 3C below – Trench Reinstatement Compaction, materials are grouped as follows
 - a) Granular materials
 - b) Bituminous materials

These materials shall be strictly to the specification and overall thickness stated in this Specification.

2. The compaction of the trench reinstatement materials shall meet the requirements of Table 3C - Trench Reinstatement Compaction Table, as below

3.05 Concrete Specifications

1. The requirements for the concrete grades shown in the Specification are for Class DS-1 conditions in accord with Table 2 of the BRE Special Digest 363 (2001). Where other than Class DS-1 conditions are encountered then the mix shall reflect the requirements of Table 2 of the above Digest. All concrete references relate to BS 8500.
2. Aggregates shall comply with BS EN 12620 including the option to utilise all-in aggregates. The stated size shall be 20mm unless otherwise stated.
3. The ratio of the combined or all-in aggregate to the cement for the most basic mixes shall be not more than 1:8 by volume or 1:10 by mass. No account needs to be taken of bulking of materials.
4. The concrete shall be batched mixed to meet the requirements of the crushing strengths as detailed within this specification. The use of hand mixes will not be permitted in any works offered to the Highway Authority for adoption.
5. The as placed concrete shall be compacted by hand or mechanical vibration means.
6. The surface finish of the installed material shall comply with Clause 2602 Ss9 of the SHW.
7. The Engineer may require the Developer to undertake compressive strength testing of Standard and Prescribed mixes. When testing is required, the strength target shall be as signified by the grade of concrete being assessed. In such circumstances all testing shall be in accordance with the relevant sections of BS1881.

Table 3C - Trench Reinstatement Compaction

Compaction Plant and Weight Category	Cohesive Materials (Less than 20% granular content)			Granular Materials (Greater than 20% granular content)			Bituminous Materials (All bituminous materials and asphalt)			
	Compaction passes required/Layers of compacted thickness up to:			Compaction passes required /Layers of compacted thickness up to:			Compaction passes required /Layers of compacted thickness up to:			
Vibro Tamper 50kg minimum	100mm	150mm	200mm	100mm	150mm	200mm	40mm	60mm	80mm	100mm
	4	8*	Unsuitable	4	8*	Unsuitable	5**	7**	Unsuitable	Unsuitable
Vibrating Roller 600-1000 kg/m twin drum 1000-2000 kg/m twin drum 2000-3500 kg/m single drum 2000-3500 kg/m single drum Over 2000 kg/m twin drum Over 2000 kg/m twin drum	Unsuitable	Unsuitable	Unsuitable	6	Unsuitable	Unsuitable	5	7	Unsuitable	Unsuitable
	8	Unsuitable	Unsuitable	6	Unsuitable	Unsuitable	6	Unsuitable	Unsuitable	Unsuitable
	4	8	Unsuitable	3	6	Unsuitable	4	5	6	8
	3	6	Unsuitable	3	5	7	5	7	8	Unsuitable
	2	3	5*	2	3	4	3	4	4	6
	2	2	6*	3	4	6	4	6	7	Unsuitable
Vibrating Plates 140-1800 kg/sq m Over 1800 kg/sq m	Unsuitable	Unsuitable	Unsuitable	5	Unsuitable	Unsuitable	6	Unsuitable	Unsuitable	Unsuitable
	3	6	Unsuitable	3	5	7	4	5	6	8
Notes: Single drum indicates vibration on one drum only. Twin drum requires vibration on both drums Twin drum rollers are preferred for bituminous materials.	Minimum layer thickness 75mm			Minimum layer thickness 75mm			Compaction should be discontinued if any distress to the material is noticed.			** A Vibro-tamper shall not be permitted for the compaction of the permanent surface course applied to trenches of greater than 500mm width
	* These options are not allowed for use on wholly cohesive materials, i.e. pure clay and/or silt containing no particle greater than 75 microns									
Alternative plant for trenches less than 200mm width, small excavation and other areas of restricted access.										
Vibro-tamper 25 kg minimum	6 passes minimum			6 passes minimum			6 passes minimum			
Percussive Rammer 10 kg minimum	Maximum layer thickness 100mm			Maximum layer thickness 100mm			Maximum layer thickness 75mm			

3.06 Mortar Specifications

1. Mortar used in below ground applications shall be composed of Sulphate Resisting Portland Cement to BS 4027 or an equivalent sulphate resisting blend as defined within BS8500, and naturally occurring sand complying with the requirements of BS EN 13139:2002.
2. The ratio of cement to sand shall be 1:3 by volume. The incorporation of lime to form a mix 1:3:0.25 is optional (cement: sand: lime). Allowance shall be made for bulking of the sand in mortars.
3. The mortar shall be mixed by machine to a uniform colour and consistency, with the constituent materials being accurately gauged.
4. Mortar shall be made in small quantities only as and when required. Mortar that has begun to set or which has been mixed for more than two hours shall be discarded. No addition of water is permitted for any material after discharge from the mixer.
5. When gullies, manholes and the like are to be trafficked within a period of less than seven working days, then rapid set additives must be used to achieve a rapid set suitable for the work to be progressed.

4.0 EXCAVATION AND FILLING

4.01 Soil and over burden Strip

1. All turf, topsoil and other organic and unsuitable material shall be stripped from the site of all carriageways, cycleways footways and below embankments or where directed to a minimum depth of 150mm and a maximum depth as required.
2. If required as part of the Section 38 or Section 278 works the topsoil material shall be stacked to a maximum height of 2m and kept separately from other excavated or imported materials.
3. No material shall be deposited within 5m of any tree or as directed if a Tree Preservation Order (TPO) is in place.

4.02 Excavation to Formation

1. The area of the proposed works shall be excavated to formation level and any unsuitable material exposed shall be removed and replaced with approved suitable granular material to Clause 4.06.
2. Where an existing ditch falls below the proposed works it shall be thoroughly cleared of all vegetable matter, topsoil and other unsuitable material. The treatment of such a ditch will be considered on a site by site basis, but refer to clause 4.03.2 below.
3. Drainage of the sub-grade needs to be considered for all estate road designs – refer to Section 8.0.

4.03 Areas Below Formation

1. Areas below formation level after removal of turf and topsoil and other organic and unsuitable materials shall be made up with approved suitable fill material that must be of a consistent type (refer to Section 2.0), subject to clause 4.03.4.
2. Any filling of any ditch, dyke or the like, that is to form part of the works to create an adopted public highway shall be approved by the appropriate District Council, Internal Drainage Board or the Environment Agency. Before any works commence the Developer will provide written approval for such filling to the Engineer.
3. Either material to clause 4.06 or Type 1 or Type 2 material shall be used to backfill and for infill of isolated deep pockets such as old sumps, basement voids, etc., unless an alternative method is agreed in writing by the Engineer. Any vertical walls shall be broken out to below formation level and disposed of outside the limits of the adoptable Highway, subject to clause 4.03.4.
4. Where filling of areas liable to flooding is required the Developer will need to provide a full method statement and detailed specification of such works to the Engineer for approval. The submission must also contain all the necessary approvals from the relevant bodies agreeing that these works can be undertaken.

4.04 Forming Areas of Fill

1. All materials for replacement or making up to formation level in accordance with the above requirements shall be deposited in layers and each layer thoroughly compacted in accordance with Table 3A – Earthworks Compaction.
2. Where the formation of, or extension to an existing embankment is required as part of the works the Developer will need to provide a detailed specification of such works to the Engineer for approval. The submission must also contain all the necessary approvals from the relevant bodies agreeing that these works can be undertaken.
3. Where the widening to existing carriageways on embankments is required as part of the works the Developer will need to provide a detailed specification of such works to the Engineer for approval. The submission must also contain all the necessary approvals from the relevant bodies agreeing that these works can be undertaken.

4.05 Areas Liable to Flooding and Suitable Granular Material

1. Where filling of areas liable to flooding is required the developer will need to provide a detailed specification of such works to the Engineer for approval. The submission must also contain all the necessary approvals from the relevant bodies agreeing that these works can be undertaken.

4.06 Granular Material Backfill

1. Approved suitable granular backfill material shall include the following characteristics:
 - a) 10% fines value must exceed 40kN tested on a soaked basis in accordance with BS812
 - b) Maximum particle size not to exceed 63mm
 - c) Generally well-graded (coefficient of uniformity >10) and with not more than 10% passing 63um sieve
 - d) The material shall not contain any clay lumps or any other foreign matter
2. Alternatively Type 1 or Type 2 sub-base may be used.

4.07 Geotextiles

1. Where fill is placed in areas below formation a suitable geotextile will be incorporated between any Clay formation and Fill material to facilitate construction, but note the requirements in clause 1.02.4.
2. The cutting of the geotextile after placement shall be kept to a minimum. If cutting is unavoidable all the underlying sub-formation must be fully covered with any joints being overlapped by at least 300mm.
3. The use of geotextile membranes must comply with clause 7.03

5.0 BACKFILLING TRENCHES

5.01 Backfill Materials

1. All trenches under the proposed adopted public highway shall be backfilled with a suitably compacted material that shall include the following characteristics:
 - a) 10% fines value must exceed 40kN tested on a soaked basis in accordance with BS812
 - b) Maximum particle size not to exceed 63mm
 - c) Generally well-graded (coefficient of uniformity >10) and with not more than 10% passing 63um sieve
 - d) The material shall not contain any clay lumps or any other foreign matter
2. Alternatively Type 1 or Type 2 sub-base may be used.
3. Where the crown of any pipe or duct is with 1.2m of the proposed surface of the adopted public highway the pipe or duct shall be protected with a concrete pipe surround constructed in accordance with clause 16.03.

6.0 WEATHER CONDITIONS

6.01 Earthworks Operations

1. Subgrade drainage shall be incorporated as required in Section 8.0.
2. Continued working in wet conditions will adversely affect the subgrade and sub-base. If these materials have deteriorated due to trafficking or to ingress of water or the like, they shall be removed and replaced as necessary with new Type 1 sub-base material to clause 9.02.
3. No material in a frozen condition shall be incorporated in the works.

6.02 Construction

1. Material for use in construction shall not be laid on any surface, which is frozen or covered with snow, ice or frost.

2. **Table 6A - Adverse Weather Requirements for Bituminous Materials**

Material	Commence Working Air Temp	Additional Requirements	Cease Working Air Temp
Asphaltic Concrete to BS EN 13108-1	-1°C & rising	Ground unfrozen and free from ice	0°C & falling
Base and Binder course to BS EN 13108-4	-1°C & rising	Ground unfrozen and free from ice	0°C & falling
All surface courses	-1°C & rising	Ground unfrozen and free from ice	0°C & falling

3. Still air shall be defined as that moving at less than 10Km/h when measured with an anemometer located 2m above the surface of the area to be surfaced. All laying shall cease when the wind speed reaches 40Km/h and above.
4. No bituminous material shall be laid during periods of rain, that are predicted to last more than two hours or when more than 1mm/hr falls.
5. Minimum rolling temperatures as below:

Table 6B– Asphalt BS EN 13108-4 & 5 (also SMA/CASC)

	Type	Temperature (Centigrade)
Maximum at any stage	40-60 pen bitumen Surface Course/Binder/Base	190
	CASC PMB	185
Minimum Delivery *	40-60 pen bitumen Surface Course	140
	Binder/Base	120
	CASC PMB	150
Minimum Rolling#	40-60 pen bitumen all courses	85
	CASC PMB	100
	#Temperatures by which all compaction shall be substantially completed	

* At or near these temperatures the supplier should be requested to increase the delivery temperature in accordance with BS 594987: 2015.

Table 6C – Dense / Close Graded asphaltic concretes BS EN 13108-1

	Type	Temperature (Centigrade)
Maximum at any stage	40-60 pen bitumen Macadam	190
Minimum Delivery *	40-60 pen bitumen Macadam	120
Minimum Rolling	40-60 pen bitumen Macadam **	105
	Temperatures immediately prior to rolling	

** This temperature is dependent on adoption of minimum layer thickness in accordance with table 6A BS 594987, 2015.

6. Roadworks materials containing cement shall not be laid when the air temperature in the shade is below 3°C on a rising thermometer.
7. Where fresh concrete or mortar containing Portland cement CEM 1, has been placed in the works and the temperature falls or is likely to fall below freezing within a period of up to 48 hours after placing, suitable insulation blankets shall be employed and held in place for at least three days and until the air temperature is above 1°C and rising. Insulation blankets shall be closed cell polyethylene foam sheets minimum 10mm thick with a 'U' value of 4 watts/mC or suitable material with an equivalent or better thermal capacity. The Developer must be aware that the incorporation of additives or cement replacements may retard early strength development. Where this is the case care must be taken to ensure damage does not occur after the initial 48hr period.

7.0 PREPARATION OF FORMATION

7.01 Shaping and Compaction

1. After reinstatement of any defective areas, the formation shall be cleansed of mud, slurry and any detritus prior to being compacted as per Table 3A – Earthworks Compaction. The resulting profile shall be properly shaped, even and uniform surface to a level appropriate to the approved design thicknesses in accordance with Section 2.0 and Appendices 1, 2 and 3.
2. Any depressions that occur during compaction shall be filled with a suitably compacted material that shall include the following characteristics:
 - a) 10% fines value must exceed 40kN tested on a soaked basis in accordance with BS812
 - b) Maximum particle size not to exceed 63mm
 - c) Generally well-graded (coefficient of uniformity >10) and with not more than 10% passing 63um sieve
 - d) The material shall not contain any clay lumps or any other foreign matter
3. Alternatively Type 1 or Type 2 sub-base may be used.

7.02 Weather Protection

1. The formation shall be adequately protected from the weather and shall not be used by construction traffic. It shall be covered as quickly as possible with sub-base.
2. The subgrade shall be drained as necessary in accordance with Section 8.0.

7.03 Geotextiles Requirement

1. If the equilibrium CBR of the formation is less than 5% or the formation is formed within a cohesive material, a separating membrane with the properties set out below shall be laid on the prepared formation in accordance with the manufacturers' instructions.
2. The separating membrane shall extend 300mm further than the limits of the kerb beam and comply with SHW specification Clause 609 subject to:
 - a) The 090 shall be greater than 50 and less than 200 (BS EN IOS 12956: 1999)
 - b) The minimum tensile strength in each direction shall be 6kN/m (EN ISO 10319: 1996)

8.0 DRAINAGE OF SUBGRADE

8.01 General

1. On all sites measures must be installed that will maintain ground water at more than 300mm below formation level. The requirement for subgrade drainage may only be waived after ground investigations have been undertaken which can prove to the Engineer that it is not necessary. The subgrade drain pipes must be run to an approved outfall. Refer also to Section 1.01.

8.02 Alternative Provision

1. Where sub-grade drainage has been found to be necessary, but a practical design is not possible then, separating membranes shall be placed above and below an additional 150mm of Type 1 that is to be installed below and extra to the depth of construction required by the Plasticity Index.

9.0 CARRIAGEWAY FOUNDATION

9.01 General

1. Refer to Section 2.0 and Appendices 1, 2 and 3 for design depths of construction.
2. Sub-base materials shall be spread evenly on the formation in layers of a depth of not more than 150mm compacted thickness and compacted in accordance with the requirements of Table 3B – Sub-base Compaction, at a moisture content in the range optimum - 2% or + 1% and without drying out or segregation.
3. The full thickness of the sub-base shall be continued for a distance of 300mm beyond the limits of the kerb beam.
4. The Environment Agency shall be consulted over the use of any material that may contain contaminants and which could generate an unacceptable leachate.

9.02 Sub-Base Materials

1. SHW Clause 803 Granular Sub-base Material Type 1 shall be used. The material shall comply with the full requirements of SHW Clause 803 Granular Sub-base Material Type 1 including acceptable secondary and recycled aggregates, only with the Engineer's approval.
2. For housing estate roads only, Housing Estate Road Sub-base (HER) may be used as an alternative. See table 9A below.

Table 9A - Housing Estate Road Sub-base (HER)

BS sieve size	Range of grading % by mass passing
63mm	100
31.5mm	74 - 100
16mm	44 - 80
8mm	30 - 65
4mm	18 - 42
2mm	13 - 35
1mm	8 - 28
0.250mm	0 - 18
0.063mm	0 - 9

3. The material shall be crushed rock, slag, crushed concrete or other approved material. It shall be well graded and lie within the grading envelope in Table 9A.

In the above Table

- a) the particle size shall be determined by the washing and sieving method of BS EN 933: Part 1: 1997

- b) The material passing the 425um BS sieve when tested in accordance with BS 1377 shall be non-plastic
 - c) The material shall have a soaked 10% fines value of 40kN or more when tested in accordance with BS 812.
4. Copies of compliant test data in accordance with clause 9.02 undertaken by a UKAS accredited laboratory must be submitted to the Engineer prior to material being delivered to site. All test data must have been undertaken within the prior 12 weeks.
5. Acceptance of the foundation layer (sub-base) will be based upon an end product performance testing regime. The Developer is required to undertake lightweight deflectometer testing (LWD) to ensure a minimum foundation surface modulus stiffness value is achieved prior to the placement of any subsequent asphalt layers.
6. It should be noted that the Highway Authority still reserves the right to use the surface modulus stiffness values in conjunction with their own engineering experience in order to make a final decision on acceptability of the foundation layer.
7. In order to achieve these minimum surface modulus stiffness values the sub base material will have to be supplied, installed and compacted at somewhere near the optimum moisture content value in accordance with clause 9.02 above. It is also worth noting that any segregation may result in failures. Please note that once the sub-base has been delivered to site the control of the moisture content becomes the responsibility of the Developer.
8. Foundation Layers: Dynamic Plate Testing Methodology
- a) The main function of the foundation layers within a highway design is to distribute applied vehicle loads to the underlying sub-grade, without causing distress in the foundation layers or in the overlying layers. This function is required for the full life of the pavement.
 - b) In order to demonstrate that the foundation layer have been correctly installed as per this specification, the Highway Authority will require that prior to the laying of any bound materials that a series of Dynamic Plate Tests be undertaken, to ascertain the Foundation Surface Modulus. The Testing protocol shall conform to the requirements of Advice Note 73/06 Rev. 1 (2009) Design Guidance for Road Pavement Foundations or its successor document.
 - c) The tests must be carried out using the following procedure:
 - i. The testing must be undertaken a maximum of 5 working days before the laying of the bound layers. If adverse weather conditions prevail, the sub-grade is trafficked or other actions that may affect the performance of the material occur between the taking of the tests and the laying of the bound layers the Highway Authority reverses the right to instruct that the tests be carried out again. In order to give the Developer the maximum amount of time available to remediate any potential defects, the LWD test house must indicate to the Developer and the Engineer any potential failures whilst on site. The test house is

- not required to offer any contractual remediation advice to the Developer or their sub-contractors.
- ii. The spacing of the tests shall be as follows:
 - a. On lengths of less than 100m tests shall be taken every 5m
 - b. On lengths of 100m and above tests shall be taken every 10m
 - c. Tests shall be taken between these lengths when reasonably requested by the Highway Authority's representative
 - iii. Testing shall take the form of three test points, one 1m from the kerb face, one at the centreline of the carriageway and one at 1m from the opposite kerb face, (see Appendix 24).
 - iv. The contractor must carefully record the location of all plastic ducts etc., as these may adversely affect the testing regime.
- d) In order to comply with the requirements of the Highway Authority the test results (when using an IAN 73/06 rev1 compliant LWD) for the Foundation Surface Modulus shall be the rolling mean of six results and must be greater than 80MPa. For the avoidance of doubt: 80MPa is the lowest limit that the Highway Authority will accept and any measurement below this figure will have failed the test. No individual result is to be less than 50MPa. (For GDP compliance No individual result shall be less than 50 MPa)

On all LWD test results a copy of the latest calibration certificate (as specified with Ian 73/06 rev1 Clause 7.17) must be attached. These must be within 1 year of the machine being on site used otherwise the test results will be deemed non-compliant. For GDP's the latest calibration certificate in accordance with the manufacturer's recommendations must also be attached and be within 1 year of the machine being used on site.

All test results must have a test location, the recorded force (or pressure), and the deflection as a minimum for each of the 3 readings used at each test location.

The same LWD or GDP from one of the approved test houses must be used for each section of sub-base to be tested with their results being definitive and cannot be challenged by the Developer. The contractor is not permitted to utilise differing LWD's on the same section as there is a possibility of result variations depending upon variations within locations, material properties and moisture contents, hence the local authority requires numerous readings and will take a compliance view on overall trends.

Table 9B: Compliance Table

Machine Type	Minimum Individual Readings (MPa)	Minimum Rolling mean of 6 results (MPa)
IAN 73/96 rev 1 compliant (Prima or Dynatest)	50	80
German Dynamic Plate (Zorn, HMP-LFG PRO, Anix GmbH ZFG 3000 or similar)	50	N/A

- e) Testing will also be required in accordance with 8 c) iii above, where trenches are retrospectively constructed for services across the carriageway.
- f) For ease of reference a list of companies that are able to undertake the Dynamic Plate Tests can be provided by the Engineer upon request.

10.0 CARRIAGEWAY BASE LAYERS

10.01 General

1. Refer to Section 2.0 and Appendices 1, 2 and 3 for design depths of construction.
2. Bituminous materials shall be machine laid. Where agreed with the Engineer, hand laid materials may be used but shall be restricted to small areas. It should be noted that the use of tack coat (conventional bitumen emulsion) is no longer permitted as it is no longer considered best practice. Bond Coats should now be used and must be applied in accordance with BS 594987 or the rate set out in the BBA/HAPAS certificate for proprietary materials. The application requirements of Clause 920, Volume 1 of SHW must also be applied. Bond coats shall have a suitable BBA/HAPAS certificate detailing the performance claims made for them. For certificates see the BBA website: 
3. All vertical edges including kerbs, ironwork and joints shall be painted with cold applied thixotropic bitumen emulsion or hot applied bitumen immediately prior to the laying of any bituminous layer in accordance with BS 594987: 2015.
4. Any bituminous layer shall be kept clean and uncontaminated for so long as it remains uncovered by succeeding layers or surface treatment. All bituminous layers to be surfaced over, once cleansed appropriately must be sprayed with a suitable bituminous bond coat. This will be completed immediately prior to the laying of additional Base layers. For continuous laying works a bond coat shall be applied by the use of metered mechanical spraying equipment. Hand held sprayers shall only be used for very small scale works and in accessible areas and with the approval of the Engineer. Should the layer become contaminated, the Developer shall make good by thoroughly cleaning it to the satisfaction of the Engineer or, if this proves impracticable, the Developer will replace it with material to the appropriate Specification. Should the layer be damaged it shall be removed and replaced with material to the appropriate specification. See also 24.01 for further guidance.
5. The combined thickness of bound material shown in the relevant appendices shall be the minimum thickness permitted.
6. No laying of bituminous materials shall commence prior to any service installation being completed within the carriageway.

10.02 Material - Dense Asphaltic Concrete

1. The base layer materials shall be Dense Asphaltic Concrete. The materials formulation and compaction standards shall be such as to ensure individual in situ air voids are more than 2% but less than 7%.
2. Consideration will be given to Developers wishing to use material containing recycled products subject to the approval of the Engineer.
3. The material shall be AC 20 dense bin to BS EN 13108-1 and PD 6691. It shall be thoroughly compacted all in accordance with BS 594987: 2015. Binder to be 40 - 60 pen. AC 20 dense bin can be placed in one layer of 100mm when a roller of at least

8 tonne dead weight or vibratory roller of equivalent mass is available. The supplied material must be compacted in accordance with BS54987: 2015. Refer to clause 11.01.7.

4. Where a gravel aggregate is proposed a suitable design confirming the proposed adhesion additives shall be submitted. Proof shall be provided to show that the proposed mixture has been successfully laid and trafficked elsewhere.
5. If Gravel is to be used proof shall be provided to show that the mixture has been subject to the SHW Clause 929 design process and that it has been successfully laid and trafficked elsewhere.
6. Guidelines for delivery and rolling temperatures for Dense Asphaltic Concrete base layer are given in Section 6.0.

11.0 CARRIAGEWAY BINDER COURSE LAYER

11.01 General

1. Refer to Section 2.0 and Appendices 1, 2 and 3 for design depths of construction. Where the Binder course layer is to be trafficked, the binder content shall be enhanced.
2. Permitted materials on housing estate and distributor roads are as specified in clause 11.02.
3. Bituminous materials shall be machine laid. Where agreed with the Engineer, hand laid materials may be used but shall be restricted to small areas. All materials to be supplied laid and compacted in accordance with BS594987: 2015. It should be noted that the use of tack coat (conventional bitumen emulsion) is no longer permitted as it is no longer considered best practice. Bond Coats should now be used and must be applied in accordance with BS 594987 or the rate set out in the BBA/HAPAS certificate for proprietary materials. The application requirements of Clause 920, Volume 1 of SHW must also be applied. Bond coats shall have a suitable BBA/HAPAS certificate detailing the performance claims made for them. For certificates see the BBA website: [REDACTED]
4. All vertical edges including kerbs, ironwork and joints shall be painted with cold applied thixotropic bitumen emulsion or hot applied bitumen immediately prior to the laying of any bituminous layer in accordance with BS 594987:2015.
5. Any bituminous layer shall be kept clean and uncontaminated for so long as it remains uncovered by succeeding layers or surface treatment. All bituminous layers to be surfaced over, must be sprayed with a suitable bituminous bond coat. This will be completed immediately prior to the laying of the Binder Course materials. For continuous laying works a bond coat shall be applied by the use of metered mechanical spraying equipment. Hand held sprayers shall only be used for very small scale works and in accessible areas and with the approval of the Engineer. Should the layer become contaminated, the Developer shall make good by thoroughly cleaning it to the satisfaction of the Engineer or, if this proves impracticable, the Developer will replace it with material to the appropriate Specification. Should the layer be damaged it shall be removed and replaced with material to the appropriate specification. See also 24.01 for further guidance.
6. No laying of bituminous materials shall commence prior to any service installation being completed within the carriageway.
7. The combined thickness of bound material shown in the relevant appendices shall be a minimum thickness of 190mm.

11.02 Material – Dense Asphaltic concrete

1. The material shall be AC 20 dense bin to BS 13108-1 and PD6691 and laid 65mm thick. It shall be laid and thoroughly compacted all in accordance with BS 594987: 2015. Binder to be 40 - 60 pen. The materials formulation and compaction

standards shall be such as to ensure individual in situ air voids are more than 2% but less than 7%

2. Where a gravel aggregate is proposed a suitable design confirming the proposed adhesion additives shall be submitted. Proof shall be provided to show that the proposed mixture has been successfully laid and trafficked elsewhere.
3. If Gravel is to be used proof shall be provided to show that the mixture has been subject to the SHW Clause 929 design process and that it has been successfully laid and trafficked elsewhere.
4. Guidelines for delivery and rolling temperatures for Dense Asphaltic concrete Binder Course layer are given in Section 6.0.

12.0 CARRIAGEWAY SURFACE COURSE

12.01 General

1. Bituminous materials shall be machine laid. Hand laid materials may only be used where restricted to small areas and when agreed with the Engineer. All materials to be supplied laid and compacted in accordance with BS 594987: 2015. It should be noted that the use of tack coat (conventional bitumen emulsion) is no longer permitted as it is no longer considered best practice. Bond Coats should now be used and must be applied in accordance with BS 594987 or the rate set out in the BBA/HAPAS certificate for proprietary materials. The application requirements of Clause 920, Volume 1 of SHW must also be applied. Bond coats shall have a suitable BBA/HAPAS certificate detailing the performance claims made for them. For certificates see the BBA website: XXXXXXXXXX
2. All vertical edges including kerbs, ironwork and joints shall be painted with cold applied thixotropic bitumen emulsion or hot applied bitumen immediately prior to the laying of any bituminous layer in accordance with BS594987: 2015. All surface course layers to be surfaced over must be sprayed with a suitable bituminous bond coat. For continuous laying works a bond coat shall be applied by the use of metered mechanical spraying equipment. Hand held sprayers shall only be used for very small scale works and in accessible areas and with the approval of the Engineer
3. No laying of bituminous materials shall commence prior to any service installation being completed within the carriageway.
4. The combined thickness of bound material shall be as shown in Appendices 1, 2 & 3
5. The following material and depth options for carriageway surface course construction are permitted.

Appendix 1 - the material shall be: Cambridgeshire Asphalt Surface Course (CASC), clause 12.02 refers

Appendix 2 - the material shall be: Stone Mastic Asphalt (SMA) 6mm surf to BSEN13108-5, clause 12.03 or 12.04 refers.

Appendix 3 – the material shall be: Concrete Block Paving, clause 12.05 refers.

6. On roundabouts and within 60m of junction areas or abutting existing highways, then the material is to be individually agreed with the Engineer
7. Surfacing courses shall have the following minimum PSV's:
 - a) For Housing Estate and Distributor Roads - PSV 50
 - b) On or within 60m of junctions of Principle, Non-principle, Classified (Class A, B & C) roads - PSV 60
 - c) On or within 60m of roundabouts - PSV 65

8. Guidelines for delivery and rolling temperatures are given in Section 6.0.
9. Alternative materials may be considered where the Developer can produce proof of its successful use elsewhere. Producer's technical information shall be provided and prior written approval for its use shall be obtained from the Engineer.
10. Crossfalls to carriageway shall be 1 in 36.

12.02 Cambridgeshire Asphalt Surface Course (CASC)

1. The aim is to provide a dense, impermeable and durable surface course which contains a negative texture depth generally compliant to the requirements of Thin Surface Course's within Clause 942 Table 9/13. See Table 12C below.
2. CASCplus whilst being a proprietary material shall generally comply with the applicable requirements of BS EN 13108 Bituminous mixtures (as it is hybrid between Parts 1 and 5) and PD 6691 Guidance on the use of BS EN 13108. CASC shall be transported handled and laid in accordance with the requirements of BS 594987:2015 + A1:2017
3. Polished Stone Value – Coarse aggregates shall have a minimum PSV of 53 unless otherwise specified by the Engineer after reference to CD236 table 3.2a. Minimum PSV for all footway surface course material shall be 45.
4. Resistance to Fragmentation – Category LA₃₀, or as otherwise agreed with the Engineer.
5. Aggregate abrasion Value – for carriageway material, not more than 12, or as otherwise agreed by the Engineer after reference to CD236 Table 3.4
6. Durability (Water Absorption) – Category WA242 or as otherwise agreed with the Engineer.
7. When tested in accordance with the procedures in BSEN 13043, the fine aggregate shall comprise crushed rock (excluding Limestone), crushed slag fines or natural sand.
8. The use of limestone and any other material that does not comply with the minimum PSV requirements specified shall not be permitted as coarse aggregates in CASC surface courses.
9. Particle shape – The flakiness category for the coarse aggregate shall be FL₂₅.
10. Added filler shall only be crushed limestone or other approved material (which may include reclaimed filler) in accordance with the requirements of BS EN 13043, 5.2.1.
11. The standard binder grade shall be a Polymer Modified Bitumen complying with the following requirements as specified within BS EN 14023:2010:
 - Penetration Class: 6 (65 -105 mm)
 - Softening Point Class: minimum 6 (≥60 oc)
 - Cohesion by Force Ductility Class: 3

- 12 The guideline target grading for the mixture shall be as follows, unless agreed otherwise by the Engineer.

Table 12A – Target Grading

Sieve Size	Target % Passing	Tolerance	Aggregate Grading Target Limits
20mm	100		100
14mm	95-100		95 - 100
10mm	66	+/- 7%	59 - 73
6.3mm	39	+/- 7%	32 - 46
2mm	30	+/- 6%	24 - 36
0.5mm	16	+/- 4%	12 - 20
0.25mm	*	*	*
0.063mm	6	+/- 2%	4 - 8

* to be recorded only

- 13 Target binder contents guidelines shall be:

CASCPlus 5.5%
Bmin 5.0

- 14 Performance Testing: Resistance to wheeltrack permanent deformation to be measured in accordance with BS EN 12697-22:2003 – Small device, Procedure B when tested at 60°C

Classification: Class 2

Wheel Track Slope (WTS_{AIR}) (mm/1000 cycles): Maximum 1.0

Rut Depth (RD_{AIR}) mm: To be recorded only.

- 15 CASCplus shall be compacted to practical refusal following the general requirements of BS 594987; 2015 + A1: 2017 clause 9. The primary roller shall be a minimum 6t deadweight with a smaller vibrating roller as the finishing roller.

- 16 The Engineer may request the contractor at their expenses to undertake verification checks on air void contents by taking at least a pair of cores during routine works and be responsible for acceptable levels of reinstatement to the core holes. Alternatively to avoid core holes in the finished mat it would be advisable to take cores adjacent to the “ramped down” area at the end of a day’s laying operation (0.5m from ramp edge) which can be milled out the following day.

- 17 The level of Air Voids shall be tested in accordance with the Test Method: BS EN 12697-8 Using bulk density to BS EN 12697-6:2003, Procedure B Saturated Surface Dry Condition. Maximum density to BS EN 12697- 5:2009, Procedure A in water.

- 18 Air Void Compliance shall be in accordance with the Table 12B below. All testing to be undertaken by an approved UKAS accredited laboratory.

Table 12B – Air Void Compliance

Compliant Air Void Contents		
Material	Mean of Any Pair	
	Min %	Max %
CASC	2	6*
* An additional 1% void content is permitted for hand lay work		

Notes:

CASCplus initial rolling & substantial completion of rolling are >130°C & 115°C respectively.

Maximum mixing temperatures: CASCplus 185°C

19. Requirements of initial Texture depth (Revised version of Clause 942 – Table 9/13)

Table 12C – Texture depth

Road Type	Surfacing Type	Average per lane km (mm)		Average for a set of 10 measurements (mm)
		Minimum	Maximum	
All Site Locations	CASC	1.0	1.4	0.9

- 20 If requested by the Engineer, Texture depth measurement shall be carried out in accordance with BS594987:2015 + A1:2017 Clause 8.2. Whilst the Volumetric method to BS EN 13036-1 is the preferred method, the local authority will accept either the Sand Patch or vehicle mounted Laser methods. In cases of dispute the volumetric method will be definitive.
- 21 If requested by the Engineer, All sections to be tested in accordance with the Specification for Highways Works Clause 702 using a calibrated Rolling Straight Edge unless otherwise agreed with CCC. All machine laid sections of CASC to comply with the requirements of a Category A road unless otherwise agreed with the Engineer.
- 22 Unless otherwise specified by the Engineer the nominal compacted layer thickness shall be:
- CASCplus - 50mm (Minimum at any point: 40mm)
- 23 Unless otherwise agreed by the Engineer, Reclaimed Asphalt shall be permitted for use in CASC – up to a maximum of 10%
- 24 CASCplus shall be laid onto a tanker applied bond coat in accordance with

BS594987:2015 + A1:2017 + A1:2017 Clause 5.5, unless otherwise agreed with the Engineer.

- 25 All joints (both longitudinal and transverse) within the CASCplus shall be cut in accordance with BS594987:2015 Clause 6.8.2. The only exception to these is by the use of echelon paving or the use of an edge compactor.
- 26 All potential suppliers of CASCplus must supply proposed mix design data showing compliance to the enclosed specification to the Engineer. (This will cover all plants they propose to supply CASCplus from)
- 27 Upon receipt of compliant test data the suppliers will be added to an approval list for the supply of CASCplus into Cambridgeshire. It should be noted that additional guarantees or warranties such as BBA HAPAS or CE marking is not an essential requirement.

12.03 Stone Mastic Surface Course

1. The material shall be Stone Mastic Asphalt (SMA) SMA 6mm surf to BS EN 13108-5 and PD6691 designation for use on Housing Estate Roads to Appendix 2 – Estate Road only.
2. For SMA surface course material as above the binder shall be 40-60 pen and the coarse aggregate to be of crushed rock excluding limestone with a minimum PSV of 50.
3. SMA shall be laid to a compacted thickness of 40mm as shown in Appendix 1. It is not a permitted material for Appendix 2 applications.
4. The material shall be laid and thoroughly compacted all in accordance with BS 594987: 2015, with care taken to achieve a consistent even-textured finish particularly in areas of hand-lay.
5. The minimum texture depth required for SMA 6mm surf material shall be at least 0.5mm at time of laying (sand patch).

12.04 Heritage Surface Course

1. Stone mastic Asphalt (SMA) 6mm surf to BSEN13108-5 40 – 60pen but containing local 'golden' gravel' coarse aggregate, to be approved by the engineer. This material shall only be laid in footways, cycleways and trafficked areas of 20mph or less.
2. Heritage surface course shall be laid to a 40mm thickness, untrafficked texture depth of a minimum of 0.5mm.
3. Information is required that shows appropriate adhesion agents are to be added to ensure good adhesion between the gravel and the bitumen.

12.05 Concrete Block Paving

1. Concrete block paving may be used in respect of shared surfaces and may be permitted as an alternative to asphalt surfacing for roads other than Local Distributor Roads and Major Access Roads.
2. Clay block paving shall not be permitted.
3. All blockwork shall be protected from site traffic to the satisfaction of the Engineer.
4. Block paving in the form of precast concrete rectangular blocks of dimensions 200mm x 100mm x 80mm laid on a laying course may be considered as a substitute for the normal Binder and Surface course layers only as clause 12.06.8 below.
5. Blocks shall comply with BS EN 1338:2003 (in accordance with Table 7) and the permitted colours are;
 - a) medium/red/buff
 - b) dark grey/dark brown
 - c) natural/brindle
6. Blocks shall be laid on a 30mm compacted thickness of category II laying course sand in accordance with the requirements in BS7533 Part 3, 2005 + A1:2009. The method detailed in 4.3.3.a) of that document shall be adopted for installing the laying course.
7. Surface regularity for Blockwork is defined in clause 1.10.
8. Blocks shall be laid in a 90° herringbone pattern unless otherwise agreed in writing by the Engineer. Where herringbone pattern at 45 degrees is permitted, laying should be to the requirements of BS 7533 Part 3 2005 + A1:2009 utilising “mitre head” starter units and inboard cutting techniques as appropriate. Blocks to be cut using approved block cutting guillotine to no less than ¼ (one quarter) of the original plan size.
9. A carriageway Base layer 190mm thick placed in accordance with the requirements of Section 10.0 over a sub-base to Section 9.0 is required below the block paving. The Developer should refer to Appendix 3 for construction thicknesses for the sub-base layer. The base layers shall not be punctured as a drainage provision prior to installing the laying sand.
10. Gaps between kerb face and blocks and between ironwork and blocks must be kept to a minimum and sealed with a well-rammed mixture of 3:1 dry sand to Ordinary Portland Cement or propriety sealing system.
11. The Developer shall use specifically designed ironwork which permits the blockwork and its laying course to be laid up to the frame of the gully grate or manhole cover. No trimming of blocks shall be permitted other than those vertical cuts necessary to achieve the laying pattern shown in Appendix 7 – Blockwork-details around ironwork, and to accommodate the horizontal alignment of the road.

12. Proprietary blocks and systems shall only be used with the prior written authorisation from the Engineer.
13. Tegula paving shall be 80mm thick, rolled pre-cast concrete paving blocks with at least three different longitudinal sizes laid to create a random pattern using a suitable mix of the block sizes available. The blocks shall be manufactured to the requirements of BS EN 1338:2003.

13.0 KERBS AND CHANNELS

13.01 Kerb Beams and Backing

1. Kerb beams and channel beams shall be installed prior to laying Base materials.
2. Kerb beams shall be constructed of ST1 concrete to SHW Clause 2602 not less than 150mm thick and 425mm wide at the profile shown in Appendix 4 – kerb and edging details. The profile shall be formed by either using shuttering both sides of the kerb beam or by using an extruded kerb beams as shown in Appendix 23. The kerbs shall be backed with ST1 concrete as shown in Appendix 4. For channel blocks, the kerb beam width shall be increased to 680mm at the profile shown in Appendix 4.
3. Kerb beams around the inside of speed control bends and for 5m beyond the tangent points of such bends shall be increased in depth to 250mm. In some additional locations these dimensions may be required at the Engineers discretion.
4. The laying of kerbs or channel to a plastic bed and haunch is not permitted.
5. Temporary kerbing, blocks and channels shall be laid on beams prior to laying base and binder materials.
6. Adoptable kerbs and channels should not be installed until housing is completed. This will normally be carried out when all wet trades and garden areas have been completed. Any kerbing installed prior to the Engineers agreement will be considered as temporary.

13.02 Kerbs - General Requirements

1. Kerbs shall be laid to general regularity and upstands shown in Table 1C - Tolerance for other fixed surface features, of this Specification and otherwise to the construction requirements of BS7533, Part 6, 1999. Special provisions for kerbs at vehicular, cycle and pedestrian footway crossings are detailed in Section 19.0 of this Specification. All kerbs shall be laid to line and level.
2. Where asphalt surface course is employed, precast concrete kerbs shall be used unless agreed with the Engineer. Such kerbs shall be 125mm x 255mm hydraulically pressed, granite aggregate Type HB2, half batter or Type BN Bullnosed to BS EN 1340:2003, and laid upright showing a 125mm kerb face. Kerbs are to be bedded on a 25mm class 1 mortar bed within 50mm of the face of the concrete beam, laid with dry joints and backed with ST1 concrete to a minimum thickness of 150mm, to within 50mm of the top of the kerb. Where block paving is employed precast concrete kerbs shall be 125mm x 255mm Type BN, kerbs showing a 25mm face. The upstand must be of uniform height subject to the tolerances in clause 1.10.5, Table 1C - Tolerance for other fixed surface features.
3. No cut kerb shall be less than 300mm in length.
4. Any kerbs that require replacement prior to the laying of the Surface Course may expose a void between the kerb face and the adjacent Base/Binder Course layers.

This void shall be filled with a flexible/modified bituminous joint sealant that complies with either type N1 or N2.

13.03 Radius Kerb Lines

1. For curves of radius 12.5m or tighter, the appropriate radius kerb shall be used.
2. The permission of the Engineer shall be sought in all cases where it is proposed to use cut kerbs to achieve a smooth line on curves. Cut kerbs shall be of equal lengths between 450mm and 600mm and shall have suitably tapered cuts free of spalling to achieve a smooth front face to the kerb line.

13.04 Channel Lines

1. Carriageway channel lines shall be laid to gradients no flatter than 1 in 150, and no steeper than 1 in 20. The use of summated channel lines shall be permitted to achieve this. Blockwork shall be laid to gradients no flatter than 1 in 80.

14.0 GULLY GRATES AND FRAMES

14.01 General Requirements

1. Gully gratings and frames shall be Kite-marked to BS EN 124:1994. Either Cast Steel or Ductile Iron may be used. The frame shall be bedded on a gauged Class 1 (3:1) sand/cement mortar and at least two but no more than four courses of Engineering Brickwork Class 'B' to BS EN 771-1:2003. The use of proprietary concrete collars can be used in place of the brickwork.
2. Units complying with BS EN 124 Class D400 shall be used for all estate roads. These shall be hinged and must be of the "captive" type, non-rock design and Pedestrian/cyclist safe mesh grating design, and shall be installed on the side facing oncoming traffic. Minimum waterway area 990cm² with frame at least 100mm deep.
3. Gully covers and any other carriageway and footway or cycleway ironwork shall not be installed until the carriageway binder course layer is laid. During the construction process protection shall be given to all gullies and chambers from the ingress of debris.

14.02 Spacing of Gullies

1. The area of hardened surface including footways and cycleways, etc., draining into each gully will vary in proportion to the longitudinal gradient of the carriageway as indicated in the following table:

Table 14A - Maximum Drained Areas

Longitudinal Gradient	Maximum Drained Area
From 1 in 120 to steeper than 1 in 150	140 sq.m
From 1 in 80 to steeper than 1 in 120	160 sq.m
From 1 in 40 to steeper than 1 in 80	145 sq.m
From 1 in 40 to maximum 1 in 20	115 sq.m

2. Gullies shall be spaced to ensure that the drained areas do not exceed the maximum values given in the Table above. At the bottom of sag curves double gullies may be required and shall be installed at the direction of the Engineer.
3. The maximum length for any gully connection shall be 20m.
4. The maximum length over which a longitudinal fall of between 1:40 and 1:20 can be used shall be 20m. A longitudinal fall of between 1:40 and 1:20 shall be used no more than once for every 100m length of the proposed adopted public highway.

14.03 Ironwork Surrounds in Block Paving

1. The Developer shall use specifically designed ironwork which permits blockwork and its laying course to be laid up to the frame of the gully grate or manhole cover. No trimming of blocks shall be permitted other than those vertical cuts necessary to

achieve the laying pattern shown in Appendix 7 and to accommodate the horizontal alignment of the road.

2. Blockwork around carriageway ironwork shall be laid in accordance with the requirements and details shown in Appendix 7.
3. Where dished channels are used in block paved roads dished gully gratings of a compatible profile and to BS EN 124 shall also be used.

14.04 Ironworks within Cycleways/Footways/Shared surfaces

1. All gully gratings situated within cycleways/footways/shared surfaces shall be of a suitable type approved by the Engineer, as specified in 14.01.

15.0 GULLY POTS

15.01 General Requirements - Type and Size

1. Gully pots used for carriageway gullies shall be of precast concrete using Sulphate Resisting Cement (SRC) or an equivalent sulphate resistant blend as defined within BS8500 in accordance with BS 5911-6-2004 + A1:2010.
2. Gully pots shall have internal dimensions 450mm diameter by 1050mm deep, and shall be of the trapped type.

15.02 Bedding and Surround

1. Concrete gully pots shall be installed in accordance with BBA approval requirements. The Engineer would expect the pots to be set on and surrounded by 150mm of ST2 concrete sulphate resistant cement to SHW Clause 2602.

16.0 ESTATE ROAD HIGHWAY SURFACE WATER DRAINAGE

16.01 General Requirements

1. The highway surface water drainage layout shall be designed to cater for a 1 in a 100 year storm (1% Annual Exceedance Probability (AEP)). The design shall ensure that the velocity of water flowing in the pipes falls within the self-cleansing range. The Crimp and Bruges method will be used to check the capacity of the system and the flow velocity.
2. A Nomograph to assist with the design of surface water drainage is provided in Appendix 12. Guidance for using the Nomograph are as follows:
 - a) Join the diameter of the pipe on scale D and the gradient (lim S) on scale S by a straight line
 - b) The intersection of this straight line with the scale Q gives the discharge for the pipe when flowing full
 - c) The intersection of this same line at scale V gives the velocity of flow for the pipe when flowing full
 - d) Equation $Q = 2.78 \times A \times 0.9 \times 25.4$

Where A = the impermeable area in hectares and Q is expressed in Litres/second (1 hectare = 10,000 sq.m)

3. An adequate piped highway surface water drainage system, of approved pipe sizes, gradients and materials or a sustainable drainage system to clause 16.01.11 below shall be provided to an outfall.
4. Highway surface water drains shall be laid in straight lines at uniform gradients between manholes. Sight rails shall be erected at intervals of not more than 45 m and at changes of gradient.
5. Where an outfall drain or pipe unavoidably passes under land which will ultimately be conveyed to house purchase, or which will otherwise remain undedicated as highway, an Easement will be required giving the Highway Authority right of access at all times for repair and maintenance purposes. Acknowledgement of the presence of such a drain under each affected property must be safeguarded by the incorporation of a suitable Easement within the Conveyance of that property by the Developer. The Developer is required to submit a draft of any such conveyance to the Engineer for approval prior to the sale of any affected property.
6. Where an outfall, drain ditch or pipe will discharge into an existing drain or pipe or watercourse not maintainable by the Local Highway Authority, written evidence of the consent of the authority or owner responsible for the existing drain etc., to such discharge shall be provided to the Engineer.

7. Provision may be required to filter any drainage water prior to discharge into an existing drain, pipe or watercourse where pollution of the drain, pipe or watercourse may occur, or at those sites deemed especially sensitive by the Engineer.
8. No surface water outfall drain shall pass below any building.
9. Backfill to pipe runs shall be in accordance with Section 5.0.
10. All adoptable highway surface water drainage systems, including gully laterals shall be surveyed using closed circuit television with viewing and video recording facilities, subject to the discretion of the Engineer. The Developer shall provide suitable carriage equipment for the video camera such that the camera may be propelled or drawn from one end of a drain, duct or culvert, whilst the camera is in operation, without damage to the drainage system.
11. Sustainable Drainage Systems (SuDS) maybe an acceptable solution for surface water drainage in suitable environments. Any SuDS shall be subject to consideration and approval being given by the adoption authority.

16.02 Surface Water Pipes

1. The following types of pipe from approved manufacturers may be used for highway surface water drains:
 - a) Concrete pipes made with sulphate resisting cement to BS 5911-1: 2002 + A2:2010
 - b) "plastic" pipes (PVCu) twin wall with a smooth internal and ribbed external walls, with current BBA Certification
 - c) other types approved by the Engineer
2. Jointing and installation shall be to the manufacturers' specification.

16.03 Concrete Surround to Pipes and Ducts

1. Where the depth of cover to top of pipe below carriageway is 1.2m or less, all pipes and ducts, including plastic, shall have a bed and surround of 150mm ST1 concrete with sulphate resistant cement to SHW Clause 2602. The level of the upper surface of which shall in no case be less than 350mm below finished carriageway level.
2. In the case of plastic pipes measures must be taken to ensure that they do not float when the concrete is poured.
3. To maintain a degree of flexibility, 13mm thick fibreboard shall be inserted at the pipe joints to the full width of the concrete surround.
4. For porous pipes the surround shall comprise of at least 200mm of no fines concrete to SHW Clause 2603 or as agreed with the Engineer.

16.04 Soakaways

1. The use of soakaways is to be at the discretion of the Engineer and is dependent on the proven existence of continuous highly permeable strata below the surface. It is also a requirement of Building Regulations 2010 – Part H3 – Soakaways and other infiltration drainage systems - 3.25a Infiltration devices should not be built within 5m of a building or road or in areas of unstable land, or within 10m when used in areas of chalk.
2. For single soakaways to be given consideration, the minimum coefficient of permeability of the strata is 5×10^{-5} m/s. See clause 16.04.13 for the test method to be used. In the event of the above coefficient of permeability not being achieved consideration may be given to additional soakaways being “linked in” up to a maximum of 3 in total – See Appendix 16 – Linked Soakaways diagrammatic layout. The Developer is required to advise the Engineer of in-situ permeability testing with sufficient time to allow for witnessing of the testing.
3. Soil survey data must be submitted, the minimum information to be provided shall be full site records to include bore hole or trial pit logs, descriptions and depths of strata, classification of strata, by laboratory tests for soils contamination, and identification of water table depth. Any supporting evidence of seasonal variations of the water table depth must also be supplied.
4. Any necessary approvals from the local Water Authorities and/or Environment Agency must be obtained by the Developer and evidence of these approvals submitted to the Engineer before the proposal can be considered.
5. Soakaway chambers shall extend down to the proved continuous permeable stratum as approved by the Engineer. Chamber rings in permeable strata must be perforated and the lower ring must be founded on an in-situ concrete beam.
6. The maximum depth of the soakaway chamber shall be 1m above the standing water table to a maximum depth of 3m below finished ground level. A typical cross section is shown in Appendix 15 – Soakaway chamber details.
7. Soakaway volumes shall be such that they can accommodate at least the whole of a 1 in a 100 year storm (1%AEP), in the volume available above the base of the chamber and below the drain inverts (effective volume) – the diameter and the number of chambers to be adjusted accordingly. Storage may be reduced to take into account of proven percolation results, adjusted as clause 16.04.8. All percolation results must be submitted to the Engineer. A full set of supporting calculations such as “micro-drainage” or equivalent must be supplied to the Engineer for checking. Upon checking these calculations the Engineer may require additional soakaways and/or revised positioning of the soakaway chambers.
8. Allowance should be made for the in service effects of siltation and swelling, 33% for gravel/sands and “stone” layers in chalk and 50% for chalk and others. The Developer is advised to contact the Engineer to arrange for attendance on site to witness the soakage testing when it is carried out.
9. Soakaways shall be linked by overflow pipes as required by the Engineer.

10. Soakaway chambers shall not be sited under the carriageway or footway/cycleway or footpath, areas of verge must be set aside for this purpose, see also 16.04.01 above.
11. BRE Digest 365 (soakaways) is not applicable to Cambridgeshire Highway Drainage. Cambridgeshire County Council has avoided BRE drainage methods because of the difficulties inherent in the long term maintenance of this type of soakaway.
12. Cambridgeshire's currently adopted test method is a practical and simple hybrid of BS5930 and BRE365 related methods as detailed in 16.05 below. The trial pit excavated for testing is more representative of a working soakaway chamber, in terms of size and the volume of water used, than a lined borehole, and tends to relate more to a practical methodology than to strict BS5930. The falling head process reduces the quantity of water required for the site, but this can still be substantial.
13. The permeability coefficient is calculated in general accordance with BS5930, and as the Basic Time Lag is derived graphically there is no need to repeat the test (as required by BRE 365). The only interpretive element relates to which Intake Factor is applicable from the options shown in BS 5930 figure 6.
14. For further details regarding the calculations contact the Engineer.

16.05 Guidance notes for undertaking drainage soakaway testing on estate roads

1. Local Authorities within Cambridgeshire have avoided BRE drainage methods due to concerns over long term difficulties of this type of soakaway. Once the soakaway has been installed all the long term maintenance risks fall back onto the local adopting authority and as such a tried and trusted working method together with an acceptable compliant specification has to be implemented.
2. The test procedure is based around a hybrid method derived from BRE 365 and BS 5930. The reason for this was to create a practical test that will be representative of a working soakaway chamber on each specific site (the method in resume uses a trial pit as per BRE 365 but utilises the calculations within BS 5930 – Variable or Falling Head method to be used).
3. Method
 1. At the location of the proposed Soakaway Chamber excavate a trial pit for testing and take initial measurements of the length, width and depth (m) of the trial pit – try and excavate as close to possible a square section, i.e. 2 x 2 x 2m.
 2. Fill up the trial pit to the top of the sub soil strata to be tested with water and measure the start point level (L) (Nb. If topsoil exists the water level start point should not be in this layer).
 3. At one minute time intervals note the reduced water level depths. Check water level for at least one hour or until the head remains constant for a period of 10 minutes or the trial pit has drained of water.

4. At the termination of the test carry out a further smaller excavation adjacent to the test trial pit. In order to prove continuity of layer and check on water table level (this may need leaving overnight in a safe state).
5. From the data obtained at minute intervals divide this by the depth of the head at commencement and plot on logarithmic graph paper as per Figure 8 of BS 5930:1999 – Calculate the Basic Time Lag (T).
6. Calculate the intake factor (F) from 'Case d', Figure 6, BS 5930:1990. Where 'L' is the total depth of water at the start of test (as 2 above) and 'D' is the width of the trial pit (see 1 above – if there is variance between the measurements then take the smaller dimension).
7. Calculate Permeability (k) - $k = \frac{A}{F T}$, where 'A' is the cross-sectional area
8. Check for compliance against minimum requirement of : 5×10^{-5} m/s.

16.06 Surface Water Catchpit Manholes

1. Catchpit Manholes shall be provided at the head of drains, at changes of direction, pipe size or gradient and at the junction of main drains. Spacing shall not exceed 50m.
2. Upstream of the manhole at the head of a highway drain run each gully must be connected directly into the manhole and the length of gully connection must not exceed 20m.
3. Manholes shall conform in all respects with the requirements below and the Appendix 13 – Catchpit manhole details-brick type or Appendix 14 – Manhole details-precast concrete type.
 - a) Precast Concrete - Rings complying with BS 5911-3:2010 / BS EN 5911-1:2002 + A2:2010. The concrete cover slab must be Heavy Duty Reinforced Concrete to BS 5911-3:2002/BS EN 5911-1:2002 - see Appendix 14.
 - b) Engineering Brickwork - 225mm thick class B. Dimensions all as Appendix 14. The concrete cover slab shall be separately cast to the dimensions and with reinforcement all as shown in Appendix 13 / 14.

17.0 MANHOLE COVERS / FRAMES AND HEADWALLS

17.01 General Requirements

1. All manhole covers and frames intended for incorporation within the highway shall be kite-marked products to BS EN 124:1994 and badged S.W (surface water) and F.W (foul water).
2. They shall be Heavy Duty: BS EN 124 reference D400 with a clear opening of 600mm and minimum frame depth of 150mm.
3. Manhole covers and any other carriageway and footway or cycleway ironwork shall not be installed until the binder course layer is laid. During the construction process protection should be given to all gullies and chambers from the ingress of debris.

17.02 Bedding

1. The frames shall be bedded on a gauged Class 1 sand/cement mortar to SHW Clause 2404 and BS EN 1996 above two to four courses of Engineering brickwork Class B to BS EN 771-1:2003. The use of accelerating admixtures to be agreed with the Engineer prior to use.

17.03 Manhole Surrounds in Block Paving

1. The Developer shall use specifically designed ironwork which permits the blockwork and its laying course to be laid up to the frame of the gully grate or manhole cover. No trimming of blocks shall be permitted other than those vertical cuts necessary to achieve the laying pattern shown in Appendix 7 and to accommodate the horizontal alignment of the road.
2. Blockwork around carriageway ironwork shall be laid in accordance with the requirements and details shown in Appendix 7.

17.04 Headwalls

1. The design for any headwall shall be submitted to the Engineer for approval prior to any construction works associated with the same commencing on site.

18.0 FOOTWAYS AND CYCLEWAYS

18.01 Preparation

1. The formation of the footway/footpath/cycleway shall be levelled and compacted with a vibrating roller or other approved plant of suitable type to a properly shaped, even and uniform surface. Reference should be made to Section 3.0 and Table 3A – Earthworks Compaction for detailed information.
2. The formation shall be treated with an approved residual weedkiller, before construction commences. A non-woven separation membrane within the construction to limit weed intrusion prior to the installation of the base material shall be installed.
3. Bituminous materials shall be machine-laid. Where agreed with the Engineer, hand laid materials may be used but shall be restricted to small areas. All materials to be supplied, laid and compacted in accordance with BS594987: 2015. All bituminous layers to be surfaced over must be sprayed with a suitable bituminous bond coat to promote adhesion and improve impermeability.
4. All vertical edges including kerbs, ironwork and joints shall be painted with cold applied thixotropic bitumen emulsion or hot applied bitumen immediately prior to the laying of any bituminous layer in accordance with BS 549987: 2015.
5. No laying of bituminous materials shall commence prior to any service installation being completed within the footway.
6. Where footpaths or cycleways pass between walls, private land or other features that prevent the run off of highway surface water, then positive drainage will be required unless the area is contained within a SuDS design.

18.02 Sub-Base

1. The material used shall be SHW Clause 803, Type 1, HER Sub-base or SHW Clause 804, or compliant recycled material, compacted to Table 3B – Sub-base Compaction to a finished thickness shown in the following table.

Table 18A – Depth of Sub-base Materials

Type of Footway/cycleway	Depth of Sub-base
Footway/cycleway adjacent to carriageway and individual private car parking crossing of footway	225mm
Heavy vehicle, and/or shared private car parking crossing of footway	365mm
Footpath/Cycleway separate from carriageway	225mm

At the discretion of the Engineer the above thicknesses shall be increased if soft areas are encountered.

2. Special provisions for vehicular, cycle and pedestrian footway crossings are detailed in Section 19.0 of this Specification.
3. Footways/cycleways on the inside of speed control bends shall be increased in strength by increasing the base thickness to a minimum 365mm of sub-base. This strengthening shall extend 5m beyond the tangent points of the bend.

18.03 Binder Course

1. The binder course shall be 60mm compacted thickness of AC 14 close surf Dense Asphalt Concrete to BS EN 13108-1 and PD6691 with 40-60 pen binder. Consideration will be given to Developers/Contractors wishing to use material containing recycled products subject to the conditions of Clause 1.09.4.
2. The binder course for vehicle crossings shall be designed in accordance with Appendix 10. Consideration will be given to Developers/Contractors wishing to use material containing recycled products subject to the conditions of Clause 1.09.4.
3. All vertical edges including kerbs, ironwork and joints shall be painted with cold applied thixotropic bitumen emulsion or hot applied bitumen immediately prior to the laying of any bituminous layer in accordance with BS 549987: 2015.

18.04 Surface Course

1. The surface course shall comprise 25mm compacted thickness of AC 6 dense surf in accordance with BS EN 13108-1 and PD6691 with 40-60 pen binder. The coarse aggregate shall be either crushed rock or gravel. The course aggregate shall be thoroughly compacted as per Section 3.0 and Table 3C – Trench Reinstatement Compaction. It is recommended that care be taken with the installation of this type of surfacing particularly where it is envisaged that the surface will be subject to turning traffic stresses. In such circumstances it is recommended that the alternative recommended in clause 18.04.2 below is used.
2. Proprietary 6mm SMA with 40-60 pen binder mixtures formulated to be suitable for driveways and footways laid 25mm thick may be used. The material producer's installation recommendations shall be carefully followed to achieve thorough compaction. In the event of a non-proprietary generic SMA being proposed, the material shall satisfy the technical requirements of SHW reference Clause 937.
3. All vertical edges including kerbs, ironwork and joints shall be painted with cold applied thixotropic bitumen emulsion or hot applied bitumen immediately prior to the laying of any bituminous layer in accordance with BS 549987: 2015.
4. A thorough examination will be undertaken prior to adoption and any areas that show sign of any damage or deterioration shall be replaced to the full width and to the total satisfaction of the Engineer.
5. Guidelines for delivery and rolling temperatures for surface course Layers are given in Section 6.0.

6. Consideration will be given to Developers/Contractors wishing to use material containing recycled products subject to the conditions of clause 1.09.4.

18.05 Cycleway Surface Course

1. All cycleways either shared use or specifically designated for cycle use shall be coloured red. The aggregate shall be crushed granite and have a colour conforming to HUE 7.5R/3/4 and HUE 7.5R/3/8 as defined by the Munsell Chart. The binder shall be coloured using iron oxide to the approval of the Engineer.

18.06 Heritage Surface Course

1. Stone mastic Asphalt (SMA) 6mm surf to BSEN13108-5 with 40-60 pen binder but containing local 'golden' gravel' coarse aggregate.
2. Heritage surface course shall be laid to a 25mm thickness.
3. Information is required that shows appropriate adhesion agents are to be added to ensure good adhesion between the gravel and the bitumen.

18.07 Concrete Block Paving

1. Block paving in the form of precast concrete rectangular blocks of dimensions 200mm x 100mm x 80mm laid on a laying course may be considered as clause 18.07.7 below.
2. Clay block paving shall not be permitted.
3. All blockwork shall be protected from site traffic to the satisfaction of the Engineer.
4. Blocks shall comply with BS EN 1338:2003 (in accordance with Table 7) and the permitted colours are;
 - a) medium/red/buff
 - b) dark grey/dark brown
 - c) natural/brindle
5. Blocks shall be laid on a 30mm compacted thickness of category II laying course sand in accordance with the requirements in BS7533 Part 3, 2005 + A1:2009. The method detailed in 4.3.3.a) of that document shall be adopted for installing the laying course.
6. Surface regularity for blockwork is defined in clause 1.10.
7. Blocks shall be laid in a 90' herringbone pattern unless otherwise agreed in writing by the Engineer. Where herringbone pattern at 45 degrees is permitted, laying should be to the requirements of BS 7533 Part 3 2005 + A1:2009 utilising "mitre head" starter units and inboard cutting techniques as appropriate. Blocks to be cut using approved block cutting guillotine to no less than ¼ (one quarter) of the original plan size.

8. A binder course layer 60mm thick placed in accordance with the requirements of clause 18.03 over a sub-base to clause 18.02. The Developer should refer to Appendix 10 for construction thicknesses.
9. Gaps between kerb face and blocks and between ironwork and blocks must be kept to a minimum and sealed with a well-rammed mixture of 3:1 dry sand to Ordinary Portland Cement or propriety sealing system.
10. The Developer shall use specifically designed ironwork which permits the blockwork and its laying course to be laid up to the frame of the ironwork. No trimming of blocks shall be permitted other than those vertical cuts necessary to achieve the laying pattern shown in Appendix 7 and to accommodate the horizontal alignment.
11. Proprietary blocks and systems shall only be used with the prior written authorisation from the Engineer.
12. Tegula paving shall be 80mm thick, rolled pre-cast concrete paving blocks with at least three different longitudinal sizes laid to create a random pattern using a suitable mix of the block sizes available. The blocks shall be manufactured to the requirements of BS EN 1338:2003.

18.08 Footway and Cycleway Construction

1. Typical construction details are shown in Appendix 10.

18.09 Crossfall

1. The final footway/cycleway surface shall have a crossfall of 1 in 40 towards the carriageway.

18.10 Edge Supports

1. Where a footway does not abut a kerb or boundary wall a 50mm x 150mm hydraulically-pressed, precast, flat-topped, concrete edging to BS EN 1340:2003 Type EF shall be provided.
2. The precast edging must be securely bedded on a foundation of ST1 concrete to SHW Clause 2602 100mm deep and 200mm wide. It shall be backed with ST1 concrete from the back of the bedding to within a minimum of 40mm from the top of the edging.

18.11 Footpaths

1. The construction of footpaths, which are remote from carriageways, shall comply with the requirements of the footway and cycleway specification. In addition footpaths shall be constructed with edge supports on both sides, as detailed on Appendix 4 – Kerb and edging details.

19.0 VEHICULAR, PEDESTRIAN AND CYCLE CROSSINGS

19.01 Vehicular Crossings

1. Vehicular crossings shall be provided at the entrance to all, garages and residential properties with accesses of sufficient width to accommodate a vehicle.
2. A minimum of four precast concrete kerbs 125mm x 150mm to BS EN 1340:2003 Type BN shall be installed to provide a vehicular crossing with a minimum width of 3.6m. These dropped kerbs shall be set to show an upstand of 25mm with tolerances as given in, Table 1C - Tolerance for other fixed surface features.
3. The use of 125mm x 255mm Type HB2 kerbs laid flat will not be permitted and purpose made dropper kerbs shall be used to join the low kerbs to the standard upstand kerbing.

19.02 Pedestrian Crossings

1. Where pedestrian routes cross carriageways and on footways at junctions, two dropped kerb with tapers shall be provided on each side of the carriageway or junction. Any Tactile Paving shall be agreed with the Engineer prior to installation in accordance with Appendix 8 – Uncontrolled Pedestrian Crossing. The underlying construction specification for Tactile Paving must at least comply with the requirements of clause 18. The tactile paving thickness should be at least 65mm.
2. The dropped kerbs shall be set with the carriageway channel level to the tolerances given in Table 1C - Tolerance for other fixed surface features.

19.03 Cycle Crossings

1. Where a cycleway adjacent to the carriageway is interrupted by pedestrian or vehicular crossings, the change in level shall be achieved over at least two kerbs, using standard precast concrete kerbs and laid to suit in place of the standard one taper kerb.
2. The dropped kerbs shall be set to the tolerances given in Table 1C - Tolerance for other fixed surface features.

19.04 Dropped Kerbs and Alignment

1. Dropped kerbs and tapers shall comply with the requirements of BS EN 1340:2003.
2. Kerbs shall be laid to a flowing alignment and to the construction requirements of Section 13.0 of this Specification.
3. Where the interval between adjoining vehicular crossings is such that less than three kerbs show the full face of 125mm, the intervening kerbs between these crossings shall also be 125mm x 150mm laid to show an upstand of 25mm. The footway and/or cycleway between the crossings in this case shall also be constructed to vehicular access standards.

4. The concrete edging at the rear of the path shall to be lowered by 100mm to match the profile of the kerbline and maintain the cross fall of 1 in 40 towards the carriageway, as shown in Appendix 5 – Typical layout for vehicular accesses.

20.0 VERGES AND VISIBILITY SPLAYS

20.01 Grassed Areas

1. Grass areas within highway limits shall have the following treatment during construction:
 - a) A layer of topsoil fully compliant with BS 3882:2007 100mm thick, free from weeds, coarse grass and stones, shall be placed, levelled and raked smooth
 - b) Before sowing grass seed, all weeds and coarse grass shall be eradicated by use of a non-residual weedkiller, used strictly in accordance with the manufacturers' instructions and a pre-seeding fertiliser shall be applied
 - c) Selected tested grass seed complying with the requirement of the low-growth clause 20.02 below shall be sown at the rate of 30g/sqm and hand raked over
2. In the case of germination failure, sowing shall be repeated until a good growth is obtained.
3. All adoptable verges and visibility splays shall have a permanent delineation in accordance with clause 20.04 below and Appendix 29. Any alternative delineation shall be agreed with the Engineer.

20.02 Low-Growth Grass Mixture

1. A variety of mixtures are available from seed houses to suit the range of topsoil/subsoil pH encountered in Cambridgeshire. Wherever possible, preference shall be given to using suitable native grass species of local provenance, providing they comply with low growth characteristics. The mixture, British Seed Houses – Mix A22, is suggested as being suitable for general low maintenance/low growth characteristics and shall be used unless an alternative more specific to a particular soil type is available and submitted to and approved by the Engineer.

20.03 Trees and Hedges

1. The planting of any trees or hedges within the proposed public highway must be agreed by the Engineer at design stage.
2. The Highway Authority will only adopt grass verges that are required as part of the inter vehicle visibility splays at junctions or part of forward visibility. No other planting will be permitted within the grass verge that is to become adopted public highway. Outside the required inter vehicle visibility splays grass verges and any associated planting will remain private.
3. Tree pits shall be excavated to a depth of 1.4m and the base shall be broken up to a depth of not less than 150mm to assure that the pit will drain. A minimum of 150mm of 20mm gravel shall be laid at the base of the pit, this shall be covered with a water permeable geo-textile. The topsoil to the tree pit shall conform to BS 3882:2007 and shall be placed in layers of not more than 200mm and lightly compacted. The topsoil to tree pits in hard paved areas shall be set 100mm below the surface of the footway.

4. In verges each tree pit shall have a minimum area of 8sq.m per tree. In areas of hard paving the area of the tree pit shall be at least 4sq.m in area.
5. To protect the carriageway and footway sub-grades a suitable root barrier must be provided to encase in accordance with Appendices 25 and 26.
6. Tree pits in hard paved areas shall be protected by a cast iron tree grille as shown in Appendix 27. The grille shall comply with the loading BS EN 124. The 100mm gap between the tree grille and the topsoil shall be filled with a manufactured air permeable material.
7. In areas of shrub planting the topsoil shall conform to BS 3882:1994 and shall be placed in layers of not more than 200mm and compacted so that the air voids from between 10% and 15% of the volume, the depth shall be at least 600mm deep. The base of the excavated area shall be broken up into pieces not greater than 50mm in any direction to a depth of not less than 150mm.
8. Where new trees, shrubs or hedges are planted on private ground within 5m of the highway boundary or where any private front gardens abutting the adopted public highway are provided, a root barrier of 1.5m in depth shall be provided at the highway boundary, but not within the highway. The barrier shall extend for a distance of not less than 3m beyond the edge of any planting, gardens and the like, to prevent any roots from uncontrolled private planting from penetrating the adopted public highway. The barrier used must be proven to be able to contain aggressive species such as bamboos and the like.

20.04 Highway Boundary Markers in Verges

1. Where the highway boundary is to be marked in areas of grass verge or other planting the boundary marker must conform to the design in Appendix 29 or similar approved by the Engineer.
2. Boundary markers shall be set into the ground so that they are secured by the surrounding soil only. They shall be set so that 20mm of the chamfered top projects beyond the soil level. The tops of the markers shall be level and true.
3. The boundary markers shall be manufactured in sulphate resisting concrete with a minimum strength of ST3.
4. The font used for the lettering shall be Ariel, the x height shall be 20mm and the depth of the letters shall be 5mm.
5. Boundary makers shall be set at 10m intervals along straight sections of the development and at 1m centres though a radii, or as agreed with the Engineer.

21.0 COVERS FOR ACCESS TO UTILITY PLANT

1. All covers shall comply with the requirements of clause 17.01 or be certified capable of standing appropriate Heavy Duty loading.
2. All covers for access to utility plant shall be kept clear of cycleways unless agreed by the Engineer prior to installation. Any cover installed within a cycleway must have an antiskid surfacing applied as agreed by the Engineer.
3. In areas of block work in either the footway or carriageway infill covers stamped with the relevant utility badges will be required. In the carriageway covers shall be capable of standing appropriate grade A loading.
4. The Developer will ensure that utility covers are located so they are square with the carriageway, cycleway or footway, align with the general pattern within areas of blockwork and are not placed with the construction area of any form of crossing point.
5. Private utility meters shall be situated off the Highway or proposed Highway.

22.0 STREET FURNITURE

22.01 Timber bollards

1. Timber used for bollards shall be from a renewable European source and unless otherwise specified shall be oak with a minimum equivalent strength to SC5 strength class to BS 5268-2:2002. All timber is to be good quality, straight, sound, free from sap, shakes, loose knots or other defects.
2. Dimensions are shown in Appendix 21. Preservation of timber shall achieve a resistance to all forms of fungal, bacterial, and invertebrate act for a period of not less than fifteen years. All faces of the bollard shall be clean planed, bollards shall be stained with 'Palisander' from Salodin or similar approved.
3. All foundation concrete shall be ST3 and shall be compacted whilst the bollard, is held in a vertical position at the level and location required. The depth of the excavation shall be at least one third the depth of the bollard with 150mm extra below the base and 100mm clearance to all sides. Timber bollards shall be erected to a true vertical line and if in line to a true level to within ± 5 mm.
4. If a bollard is or bollards are to be erected within the grass verge a "sterile" strip of granite setts is to be laid around the bollard so that a strip no less than 100mm wide is presented to all faces of the bollard, to allow ease of grass cutting. The granite setts shall be 100mm, cubed and shall be set in ST4 concrete and pointed with Class 1 mortar.
5. All bollards shall be provided with suitable reflectorised plates measuring 125mm x 200mm to BS EN 2899-1;2001 the plates shall be aluminium and not less than 3mm thick, they shall conform to BS EN485 (1-4), BS EN 573(1-4) & BS EN515, with traffic grey to the rear. The plates shall be attached to the bollards with four number 25mm screws and the heads of the same shall be 'written off' to prevent ease of removal. The colours of the finished plates shall be red facing the flow of traffic and white on the opposite side of the road the colours shall remain stable and true for a minimum period of seven years.

22.02 Traffic Sign Posts

1. Posts shall be either: plain tubular steel and finished PVC dip coated, colour grey complying with BS EN 10305:2002 or galvanised to B.S 73(1983) and be manufactured from steel complying with the requirements of BS 4360 (1986) Welded Steels.
2. All posts shall be set into the ground at a minimum depth of 400mm with a minimum bed of 250mm of ST2 concrete and a surround of 100mm of ST2 concrete.
3. All excavations shall be dug by hand. The excavation for the post shall be backfilled with ST2 concrete to the formation of the reinstatement.
4. If a post is or posts are to be erected within the grass verge a "sterile" strip of granite setts is to be laid around the base of the post so that a strip no less than 100mm wide is presented to all faces of the bollard, to allow ease of grass cutting. The

granite setts shall be 10 mm. cubed and shall be set in ST4 concrete and pointed with Class 1 mortar.

5. All bollards shall be provided with suitable reflectorised plates measuring 125mm x 200mm to BS EN 2899-1;2001 the plates shall be aluminium and not less than 3mm thick, they shall conform to BS EN485 (1-4), BS EN 573(1-4) & BS EN515, with traffic grey to the rear. The plates shall be attached to the bollards with four number 25mm screws and the heads of the same shall be 'written off' to prevent ease of removal. The colours of the finished plates shall be red facing the flow of traffic and white on the opposite side of the road, the colours shall remain stable and true for a minimum period of seven years.

23.0 COMPLETION OF WORKS

23.01 General Requirements

1. Once the Developer has completed their works to the site and no further building works are to be undertaken, a joint inspection will be performed and the Engineers will supply or certify a list of any defects. Any defects found shall be rectified to the total satisfaction of the Engineer.
2. If the binder course has been trafficked by site vehicles for the duration of the construction period, any surface imperfections must be rectified prior to the placement of the surface course. If the damage to the binder course exceeds 30% of the surfaced area, the complete binder course layer shall be removed and re-laid, on larger multi routed developments the 30% standard will be applied to each individual road, path, footway or cycleway and not to the site as a whole.
3. The Highway Authority will not accept any scarring of any form within the surface course to any highway surface. In the event that such scarring does occur the Engineer reserves the right to have the faulty surface type within the whole development resurfaced. If the scarring has occurred on a 'side road' from a main route within a larger development, the Engineer may at his/her discretion allow the resurfacing to stop at the next original joint in the surface course. If the scarring is limited then the Engineer may at their discretion allow the developer to patch the surface course as required.
4. Damaged kerbs, channels and edgings shall be removed and replaced. If this results in damage to the footway, footpath or cycleway then a patch as required by the Engineer shall be provided.
5. The Engineer may at his/her discretion allow the Developer to patch damaged kerbs, channel blocks, edging kerbs with a suitable epoxy mortar.
6. All gully pots shall be suction cleansed, disinfected, all detritus shall be removed there from and trapped pots resealed with clean water taken from the local domestic supply.
7. The Contractor shall provide one copy of a closed circuit television video recording of each highway drainage run, including gully laterals, accompanied by a detailed report showing the location, chainage, prevailing weather conditions, date and time of survey.
8. A complete set of as built drawings in both electronic and paper format shall be provided to the Engineer prior to the date of issue of the Maintenance Certificate.

23.02 Sweeping and herbicide application

1. Channels to the carriageway shall be swept in accordance with the following schedule
 - a) Before the maintenance period - full mechanical sweep

- b) During the maintenance period - regular mechanical sweeping every three months
 - c) At proposed adoption date - full mechanical sweep
2. Sweeping shall be carried out using a mechanical sweeper to remove detritus, grass and other materials to the satisfaction of the Engineer.
 3. An approved residual herbicide shall be applied to all, channel lines, cover edges and the back of the footway, footpath or cycleway prior to adoption.

23.03 Grass Maintenance

1. Grassed areas provided under Section 20.0 of this Specification shall be fully maintained during the construction maintenance period and shall include all necessary treatment with weedkillers, fertilisers, etc.
2. Grass cutting shall be carried out in accordance with the following schedule
 - a) Before the maintenance period - full cut
 - b) During the maintenance period - cutting to 25mm maximum
 - c) At proposed adoption date - full cut
3. Grass shall be cut to achieve a finished maximum height of 25mm before adoption. All weeds and other detritus shall be removed from grassed areas to the satisfaction of the Engineer. Any areas of verge that show grow of perennial weeds shall be excavated by hand all roots etc. of the weeds etc., are to be removed and disposed of. The area will then be reseeded with an appropriate seed mix.

24.0 SAMPLING OF MATERIALS

24.01 General

1. Sampling and testing of mixtures and materials shall be carried out in full compliance with the appropriate British/European Standards. Testing and samples shall be provided as frequently as the Engineer may deem necessary to satisfy himself that the mixtures and materials comply with the appropriate specification. Results of all testing associated with the highway works shall be available, whenever required for the Engineer to inspect.
2. The Engineer reserves the right to instruct the Developer, to drill up to 200mm diameter cores through the highway construction before the surface course is applied to determine the layer thickness, materials used, construction type and standard of installation. These tests shall be undertaken at the expense of the Developer. Alternatively the Developer may be required to excavate and reinstate trial trenches at his own expense in the presence of the Engineer. Where layers are not correct in thickness or material, the road will not be adopted until the works have been corrected.
3. Where material or structural thickness are found to be out of specifications, the adoption will not take place before the defective layer(s) or material(s) have been replaced. The cost of such testing and coring shall be met in full by the Developer.

25.0 LIST OF CONTACTS FOR FURTHER INFORMATION

1. For advice or information regarding the design of electrical installations, bridges, culverts and structures and for requests for AutoCAD copies of the Appendices follow the link below.

<http://www.cambridgeshire.gov.uk/highwaydevelopment>

List of Appendices

Appendix 1	Distributor Road Carriageway Construction
Appendix 2	Estate Road Carriageway Construction
Appendix 3	Shared Use Area – pre cast concrete blocks
Appendix 4	Kerb and edging details
Appendix 5	Typical layout for vehicular accesses
Appendix 6	Typical Detail for Access Way Ramp
Appendix 7	Blockwork – Details around Ironwork
Appendix 8	Uncontrolled Pedestrian Crossing
Appendix 9	Public Utilities – Preferred Layout in footway
Appendix 10	Footway / Cycleway Construction Alternatives
Appendix 11	Stepped Construction Detail (Diagrammatic)
Appendix 12	Drainage – Nomograph for Design
Appendix 13	Drainage – Catchpit Manhole Details – Brick Type
Appendix 14	Drainage – Manhole Details – Precast Concrete Type
Appendix 15	Drainage – Soakaway Chamber Details
Appendix 16	Linked Soakaway diagrammatic layout
Appendix 17	Drainage – Trapped Carriageway Gully
Appendix 18	Box culvert section under adopted public highway
Appendix 19	Trench reinstatement in existing adopted public highway only
Appendix 20	Typical Lighting Unit Positions
Appendix 21	Timber Bollard Detail
Appendix 22	Public Utilities – Preferred Layout shared surface
Appendix 23	Extruded Kerb Beam
Appendix 24	Pavement Foundation Testing Regime
Appendix 25	Tree Pit in hard paving
Appendix 26	Tree pit in soft area
Appendix 27	Tree Grille detail
Appendix 28	Preferred private drive drainage detail
Appendix 29	Highway Boundary Marker (in soft)
Appendix 30	General Cross Section
Appendix 31	General Cross Section – Shared Surface



Job Title: **Distributor Road**

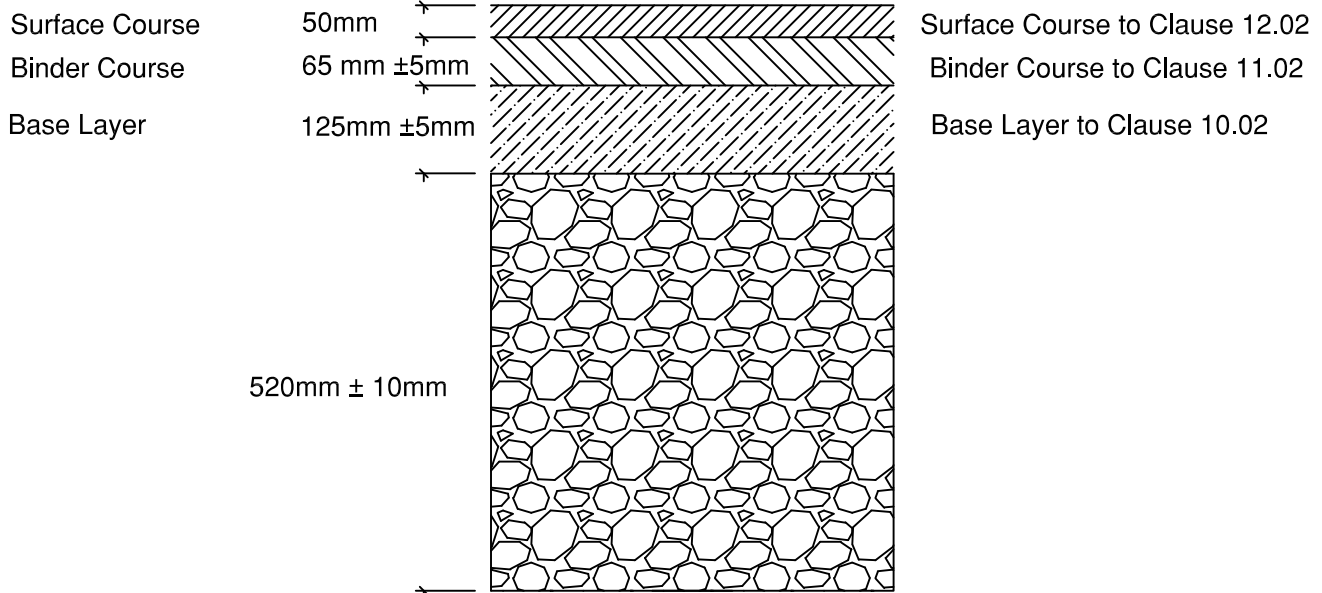

Appendix 1 - notes

1. Unless *in situ* testing has been agreed by the Engineer the CBR for the site will be assumed to be < 2% the depth of the Type 1 or Cambs. HER (Clause 9.0) Sub-base may be reduced in line with the following if suitable test results are provided.

Measured CBR values	Required depth of Type 1 or HER sub-base
CBR > 5%	260mm± 10mm (minimum thickness)
CBR 5%	280mm± 10mm
CBR 4%	315mm± 10mm
CBR 3%	375mm± 10mm
CBR 2%	450mm± 10mm
CBR less than 2%	520mm± 10mm

2. If Plasticity Index values are not available from the soil survey and test data for the proposed site, a CBR of less than 2 (<2) must be assumed for the design. A separating membrane will be required where the design CBR is less than 5% (Clause 7.03).

3. The total carriageway thickness must be at least 490mm (inclusive of sub-base).

4. The combined thickness of the bound layers as shown above shall be regarded as the minimum overall thickness for the bound materials.

5. If the 40 years life design traffic exceeds 1.0 msa a special design shall be submitted for the Engineer's approval



Job Title: **Estate Road**

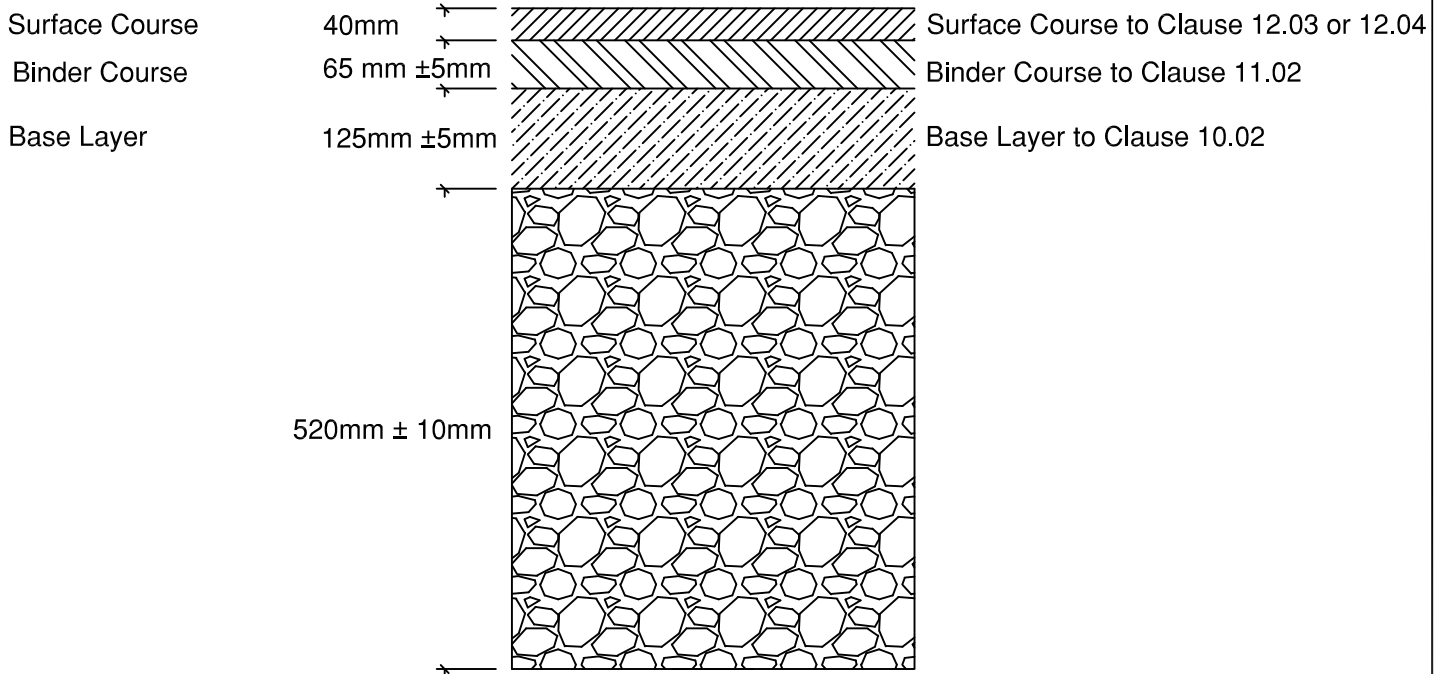

Appendix 2 - notes

1. Unless *in situ* testing has been agreed by the Engineer the CBR for the site will be assumed to be < 2% the depth of the Type 1 or Camb. HER (Clause 9.0) Sub-base may be reduced in line with the following if suitable test results are provided.

Measured CBR values	Required depth of Type 1 or HER sub-base
CBR > 5%	260mm± 10mm (minimum thickness)
CBR 5%	280mm± 10mm
CBR 4%	315mm± 10mm
CBR 3%	375mm± 10mm
CBR 2%	450mm± 10mm
CBR less than 2%	520mm± 10mm

2. If Plasticity Index values are not available from the soil survey and test data for the proposed site, a CBR of less than 2 (<2) must be assumed for the design. A separating membrane will be required where the design CBR is less than 5% (Clause 7.03).

3. The total carriageway thickness must be at least 490mm (inclusive of sub-base).

4. The combined thickness of the bound layers as shown above shall be regarded as the minimum overall thickness for the bound materials.



Job Title: **Shared Use Area: pre-cast concrete blocks**

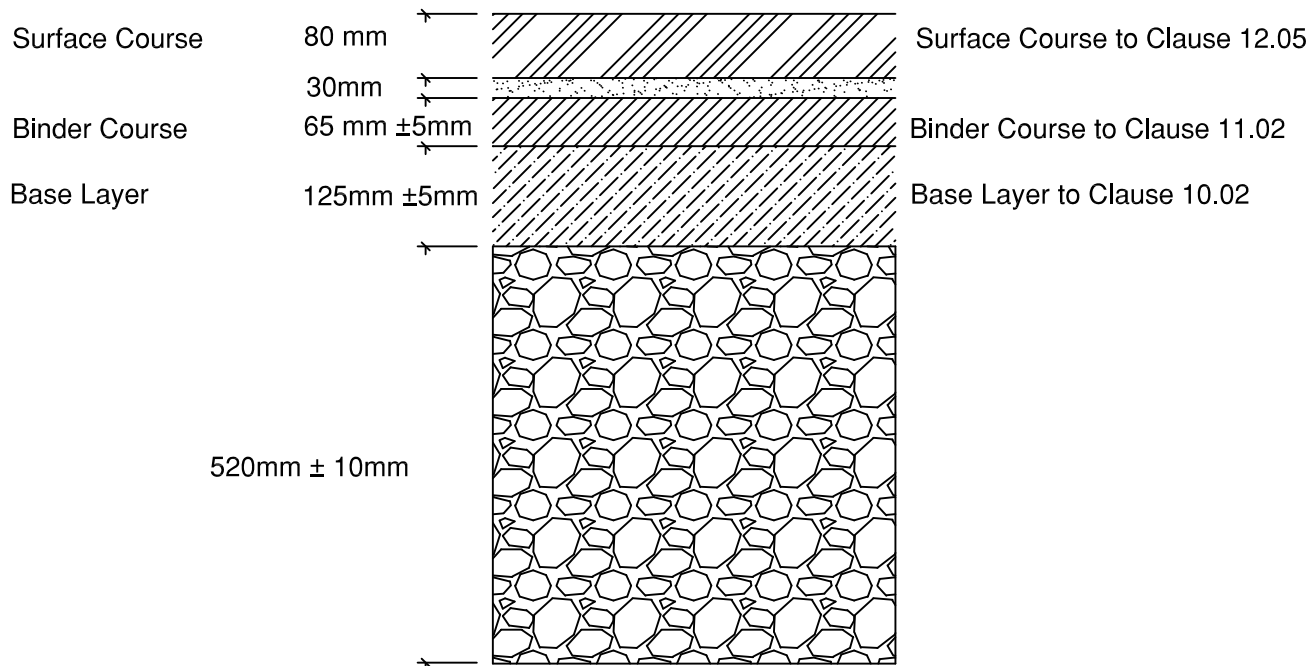

Appendix 3 - notes

1. Unless *in situ* testing has been agreed by the Engineer the CBR for the site will be assumed to be < 2% the depth of the Type 1 or Cambs. HER (Clause 9.0) Sub-base may be reduced in line with the following if suitable test results are provided.

Measured CBR values	Required depth of Type 1 or HER sub-base
CBR > 5%	260mm± 10mm (minimum thickness)
CBR 5%	280mm± 10mm
CBR 4%	315mm± 10mm
CBR 3%	375mm± 10mm
CBR 2%	450mm± 10mm
CBR less than 2%	520mm± 10mm

2. If Plasticity Index values are not available from the soil survey and test data for the proposed site, a CBR of less than 2 (<2) must be assumed for the design. A separating membrane will be required where the design CBR is less than 5% (Clause 7.03).

3. The total carriageway thickness must be at least 560mm (inclusive of sub-base).

4. Concrete Block Paving in adoptable roads is restricted to shared use areas, unless otherwise specifically agreed with the scheme approval engineer. Where Concrete Block Paving is used it must be installed over one of the road base layer options complete with sub-base as shown above.

5. The combined thickness of the bound layers as shown above shall be regarded as the minimum overall thickness for the bound materials.



Job Title: **Kerb and edging details**

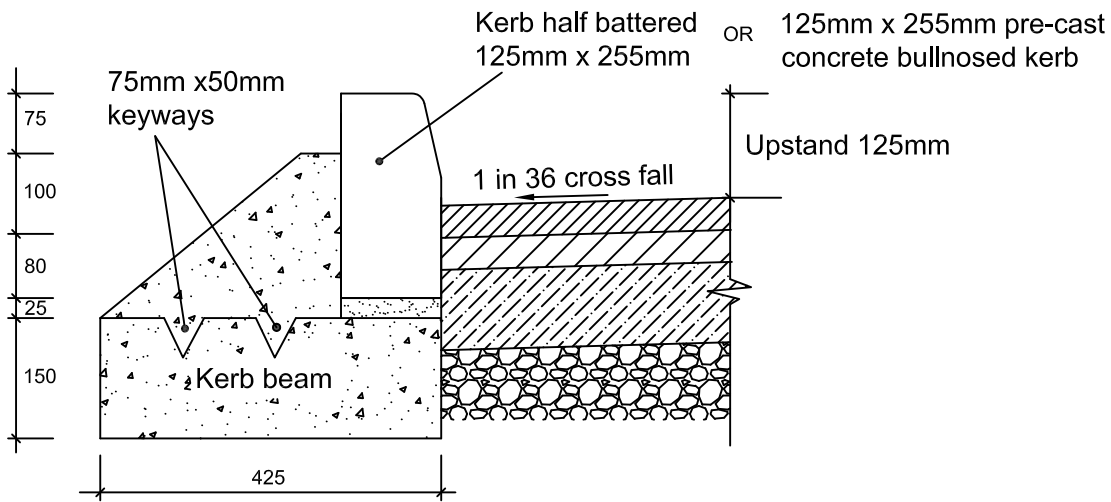

KERB DETAIL

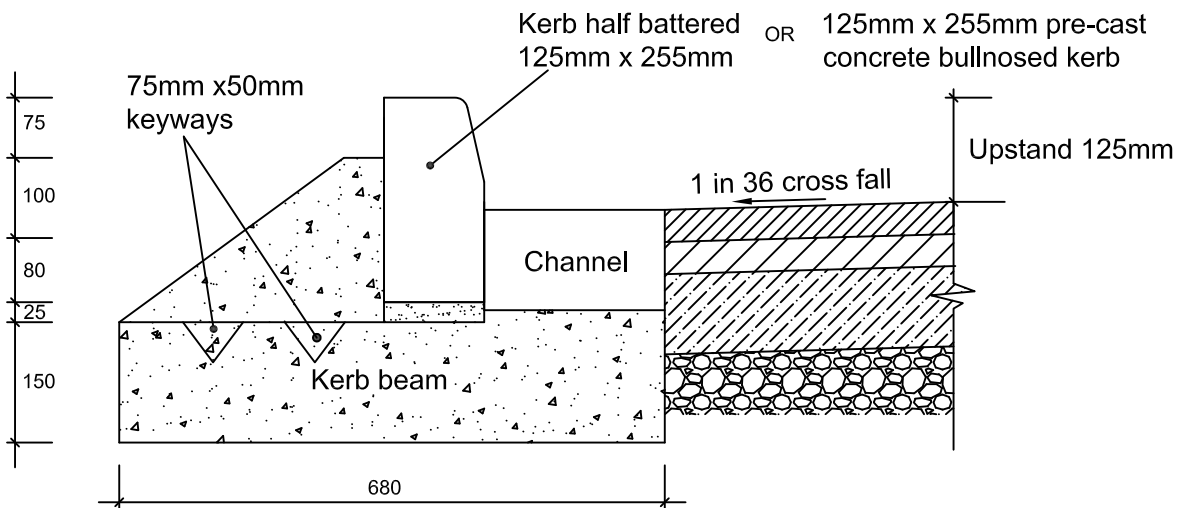

CHANNEL DETAIL

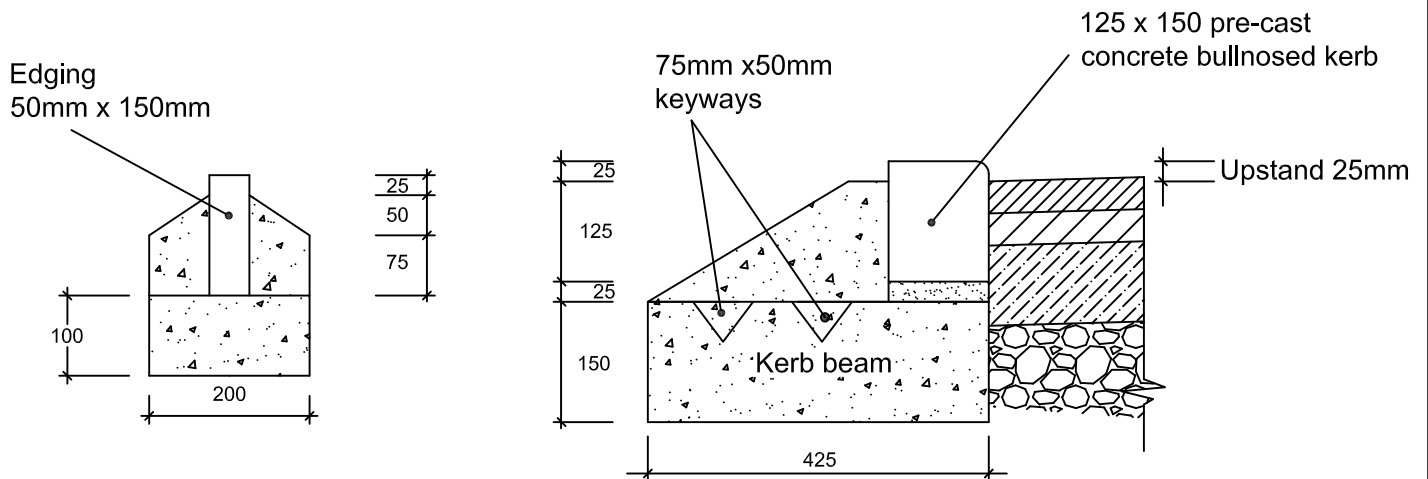

EDGING DETAIL

DROPPED KERB DETAIL



Job Title: **Typical layout for vehicular accesses**

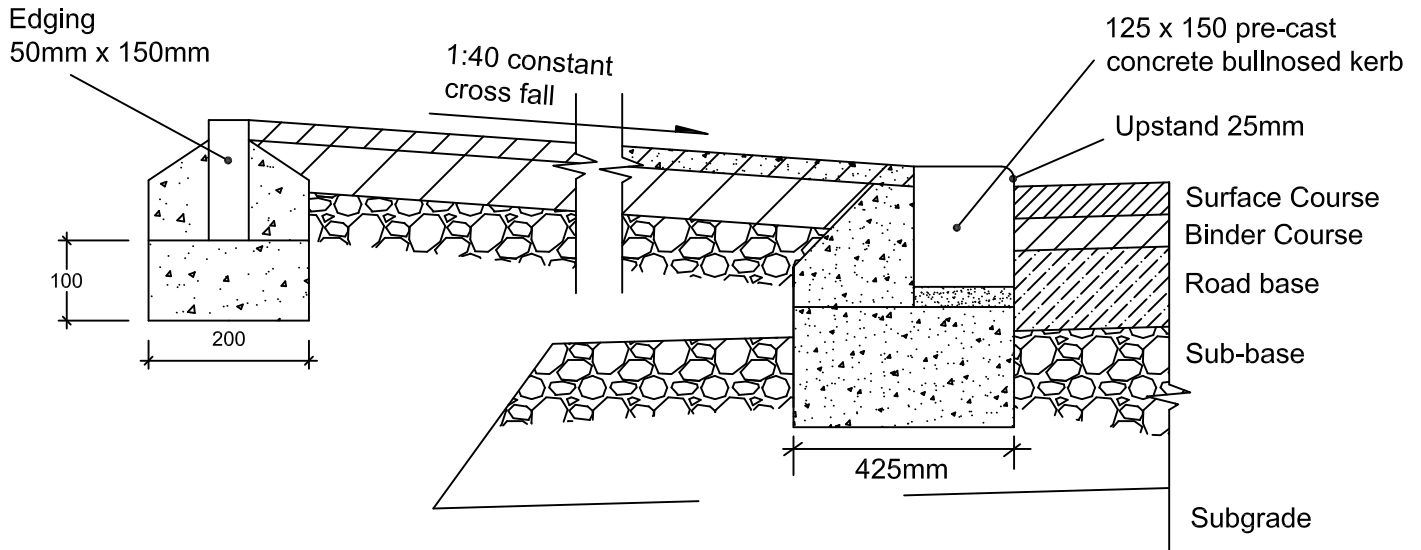

TYPICAL SECTION

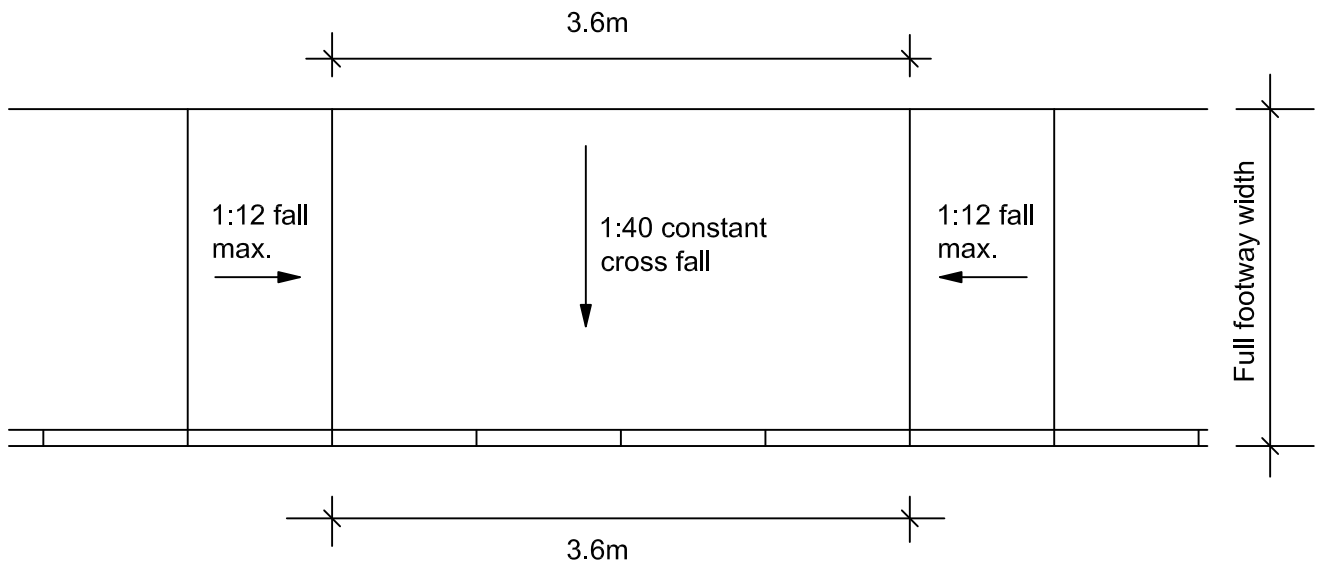

TYPICAL PLAN

NOTES

1. Depths of granular base are to be found in Appendix 10
2. Construction details for kerbs, edgings etc., are to be found in Appendix 4
3. Construction details for surface courses, binder courses and road base are to be found in Appendix 10
4. The back edge of the footway is to follow the kerb line to maintain a constant crossfall of 1:30. The longitudinal fall to the crossing across the length of the transition kerbs shall not exceed 1:12



Job Title: **Typical Detail for Access Way Ramp**

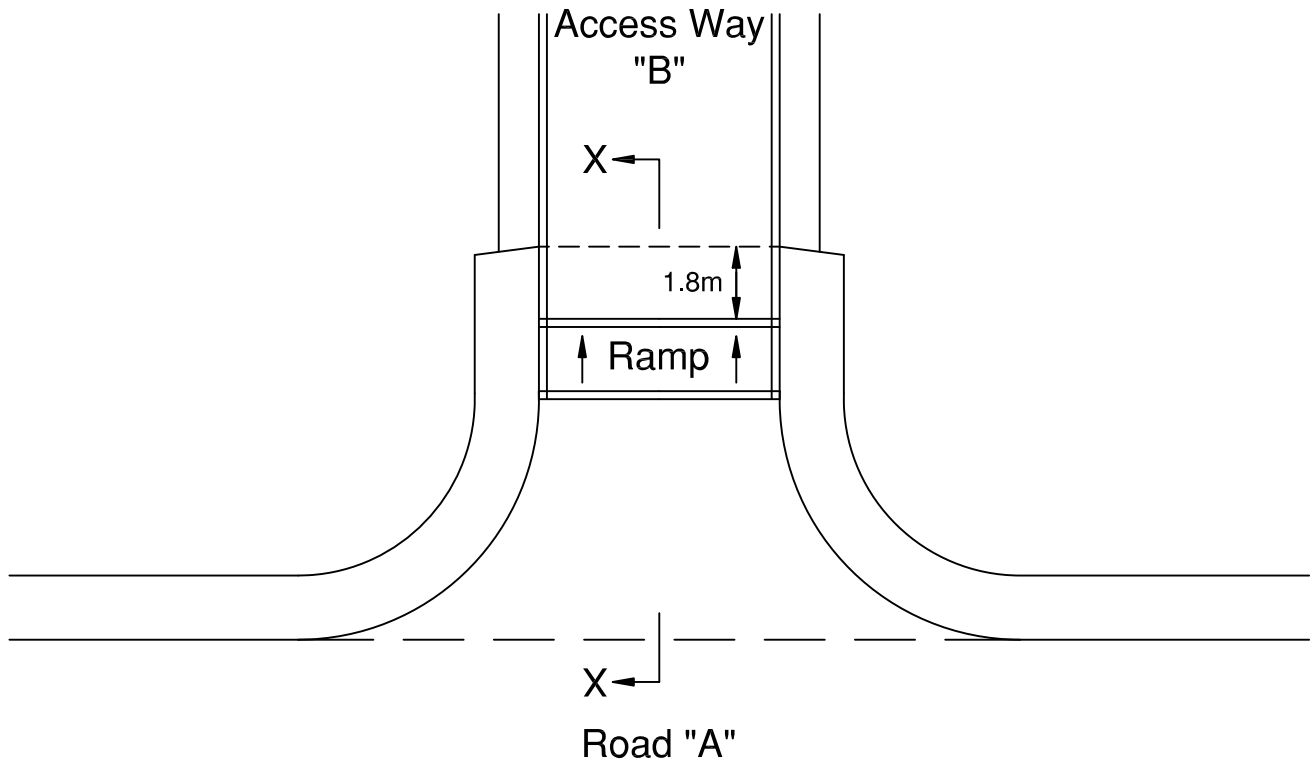

Plan of Junction Layout

100x100x100mm granite setts, bedded in and on 150mm ST2 concrete, OR min. three quarters of a sett to be bedded, max. joint width 10mm, pointed with class 1 cement mortar

200 x 100 x 80mm Concrete block paving to Clause 12.06 in a contrasting colour to the access way at the direction of the Engineer's Representative.

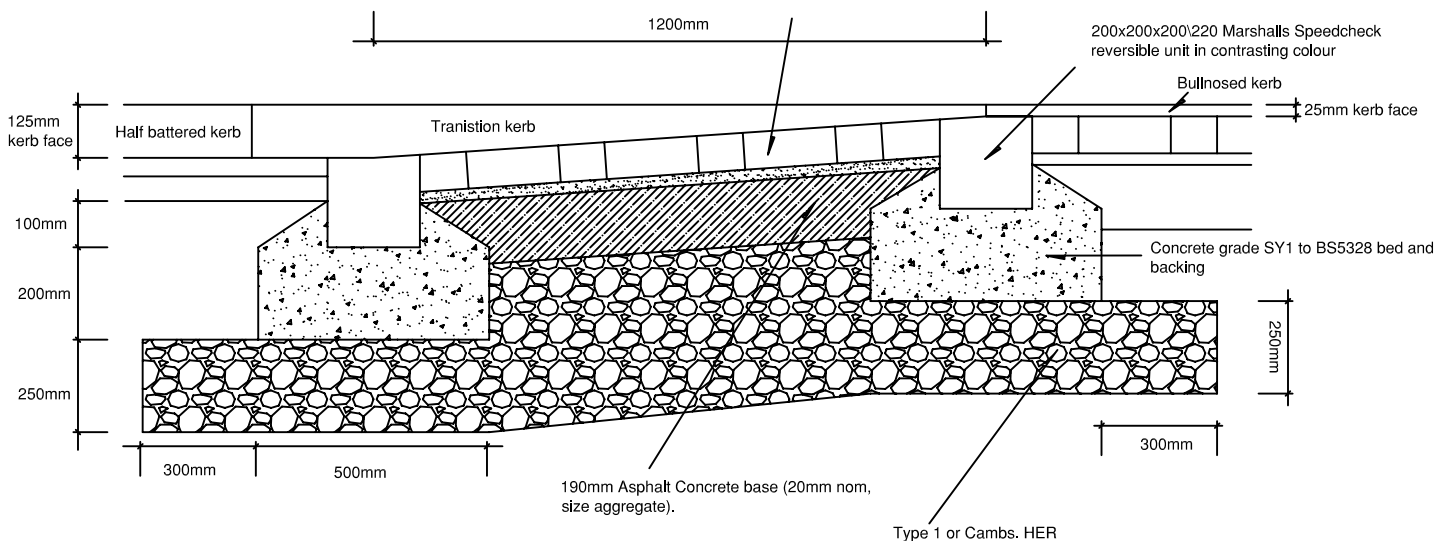

Section Through Junction X - X



Job Title: **Blockwork - Details around Ironwork**

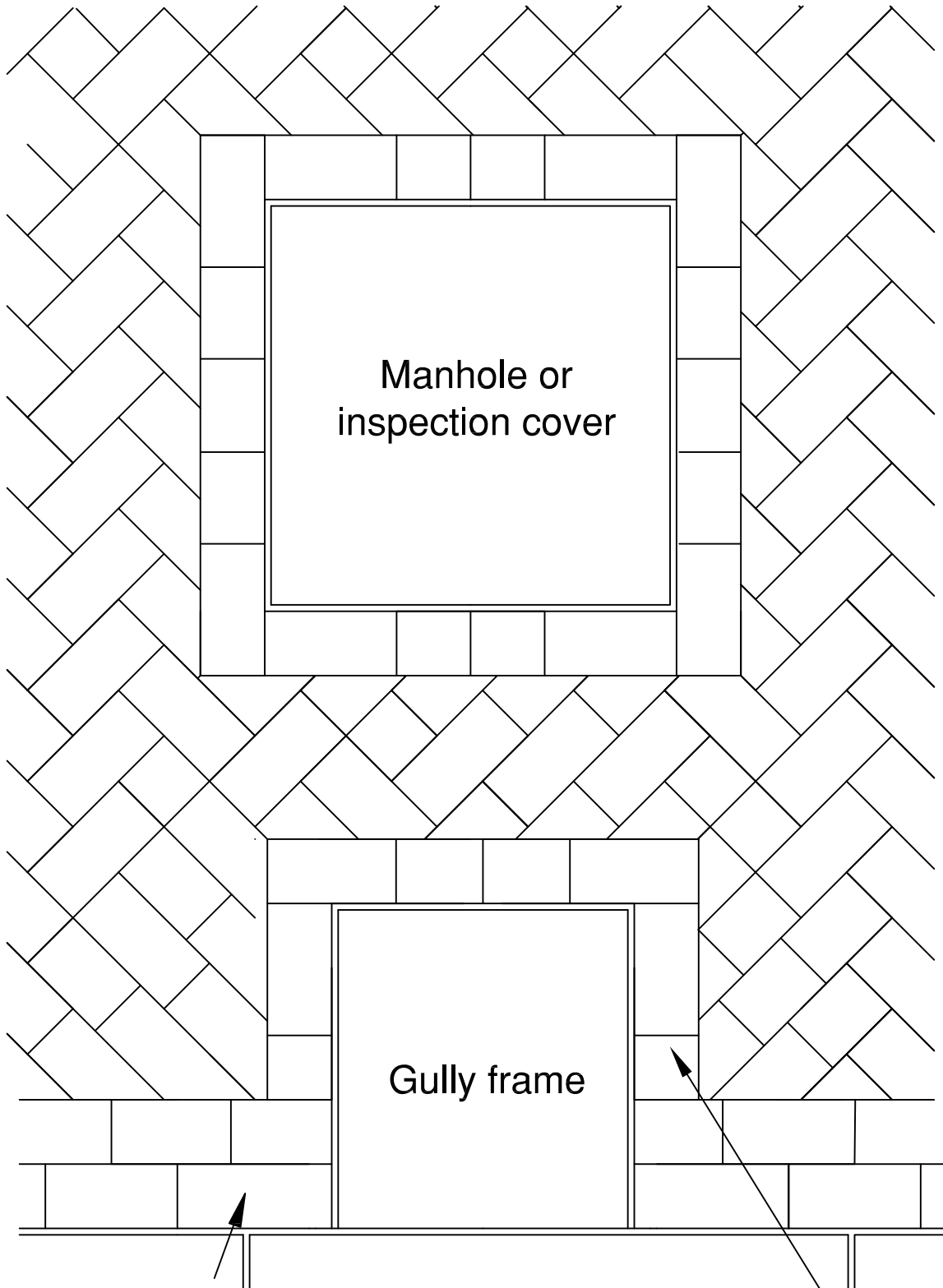

2 No stretcher courses laid
adjacent to the kerblines

Concrete blocks cut
to form surround

Note

The minimum allowable block size is a quarter block, i.e. not less than 50mm in length.



Job Title: **Uncontrolled Pedestrian Crossing**

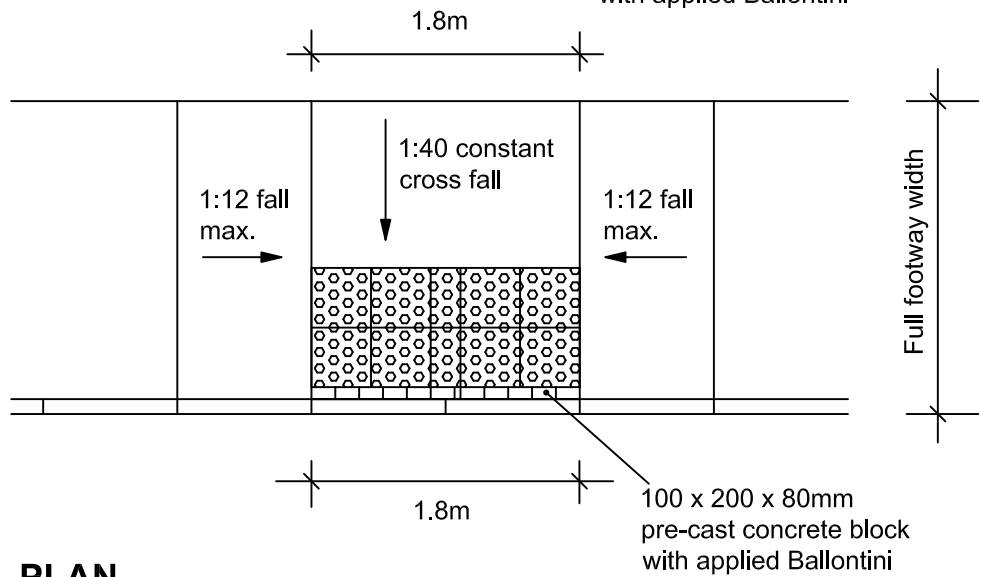
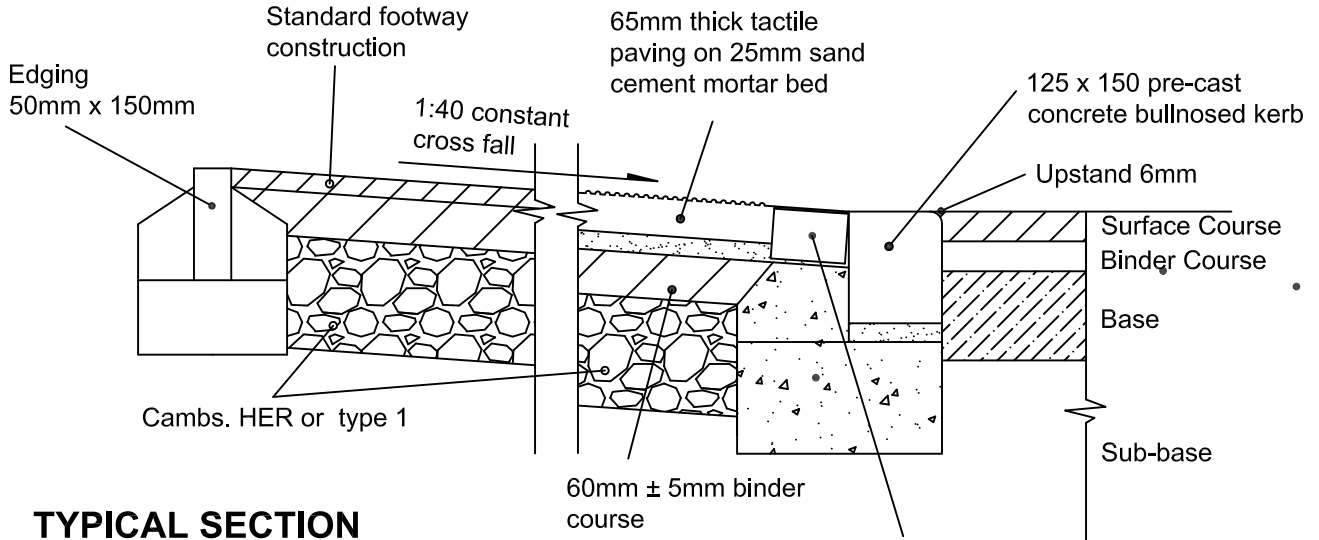

NOTES

1. Depths of granular base are to be found in Appendix 10
2. Construction details for kerbs, edgings etc., are to be found in Appendix 4
3. Binder course to base of mortar bed to slabs be to Clause 18
4. Construction details for surface courses, binder courses and road base are to be found in Appendix 10
5. The back edge of the footway is to follow the kerb line to maintain a constant crossfall of 1:40. The longitudinal fall to the crossing across the length of the transition kerbs shall not exceed 1:12



Job Title: **Public Utilities - Preferred Layout in footway**

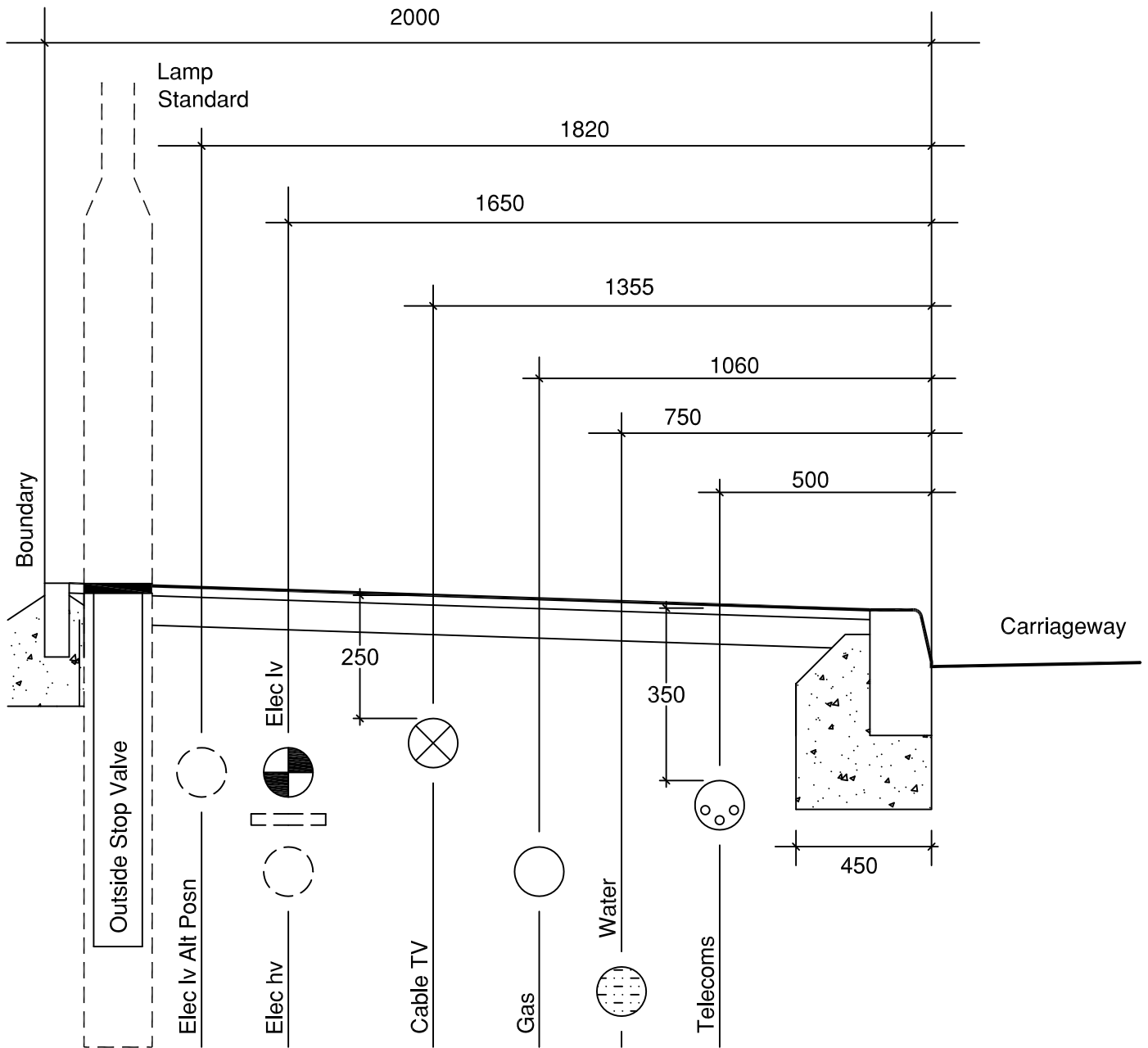

Notes

1. Preferred layout for mains in an 2000mm minimum width footway for new works, (where this width is to be provided as part of the approved layout).
2. The Developer's attention is drawn to the economic advantages of utilising "common-trenching" techniques for installation of services in footways wherever practicable.
3. The minimum depth of any service under the location of a proposed new access shall be 850mm to the crown of the duct/pipe
4. The developer will ensure that the service boxes to the Public Utilities plant are orientated so that they are in line with any blockwork areas, avoid dropped kerbs (of any type) and are in general straight to the kerb line.



Job Title: **Footway/Cycleway Construction Alternatives**

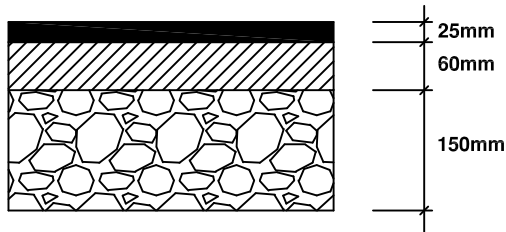

Type A: Footpath separate from carriageway (pedestrians only)

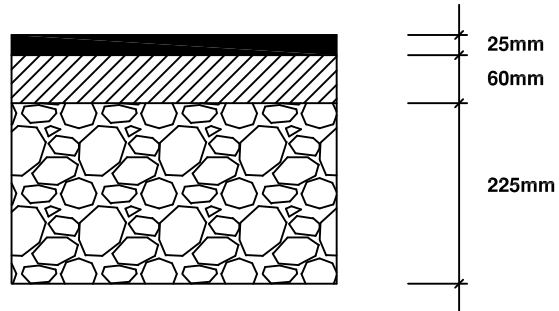

Type B: Footway/ cycleway or light vehicle crossing

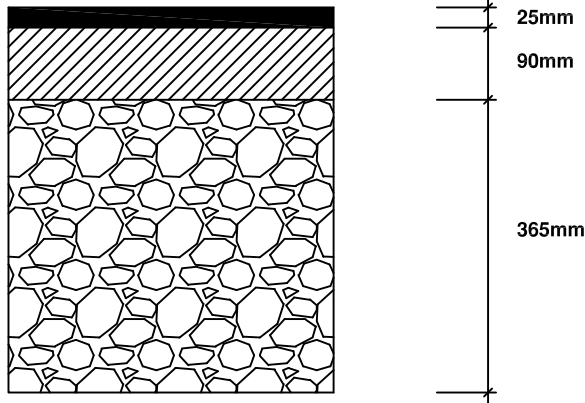

Type C: Heavy vehicle crossing footway/ cycleway

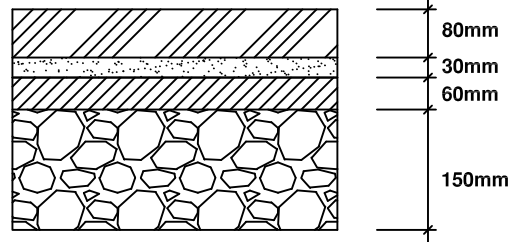

Type D: Footway (pedestrians only)

NOTES

1. Surface course to be in accordance with Part 18
2. Binder course to be in accordance with Part 19
3. Sub-base to be Specification for Highway Works Clause 803 Type 1 or Housing Estate Road Sub-base or compliant recycled material.
4. Bituminous materials shall be machine laid in accordance with Part 19
5. The formation shall be treated with and approved herbicide before construction commences.
6. The sub-base shall be laid on a 'needle punched' non-woven geofabric membrane
7. Blocks will be laid to a herringbone pattern and cut into boxes etc.





Job Title: **Stepped Construction Detail (Diagrammatic)**

New Construction

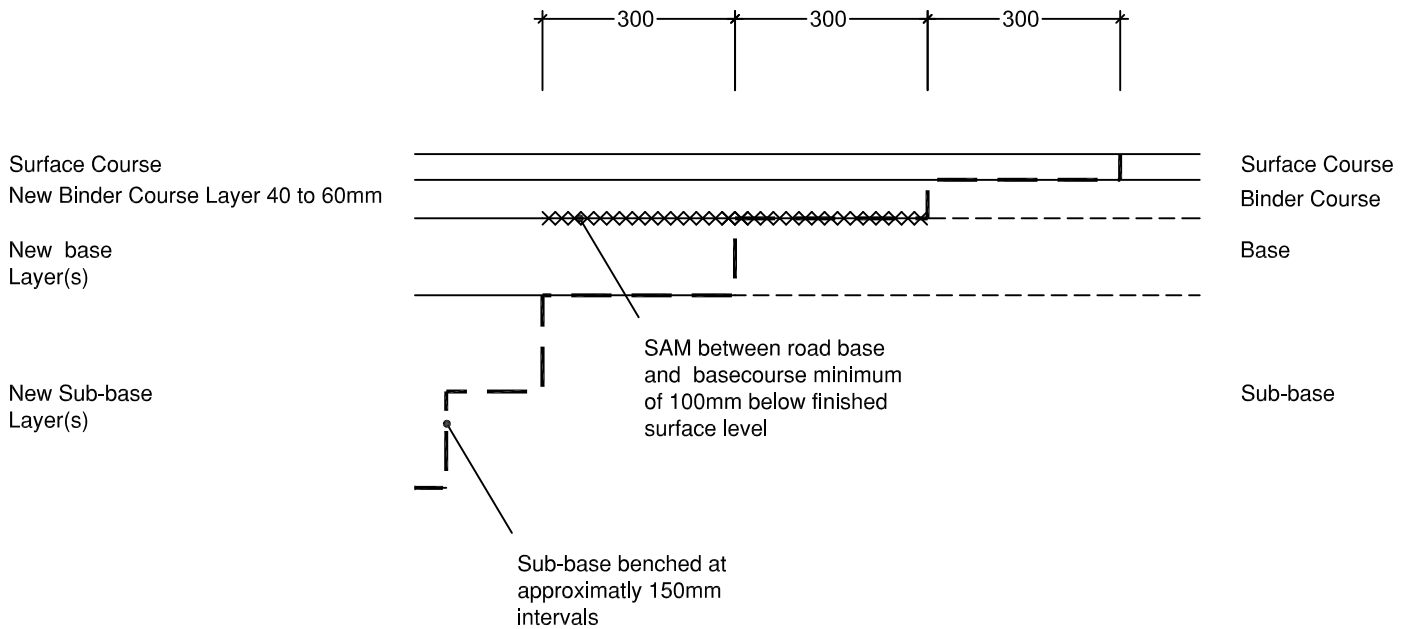
Existing Construction



Key

-  SAM (Stress Absorbing Membrane) to be either :
Glasgrid Mesh or Colas preformed SAM or TOK Paving Tape.
-  Boundary between New and Existing Construction



Job Title: **Drainage - Nomograph for Design**

Discharge and Velocity Flow for Round Pipes

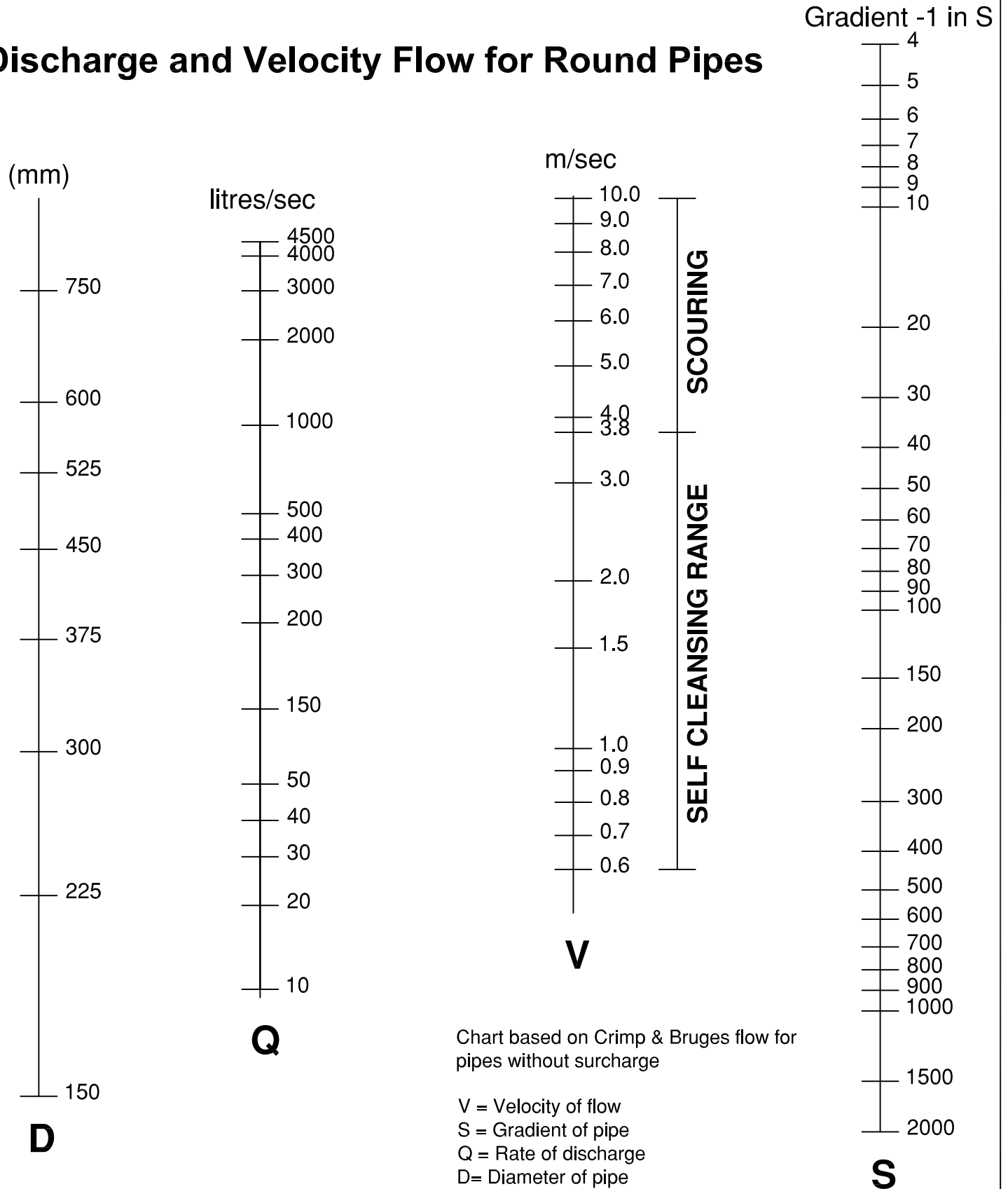



Job Title: **Drainage - Catchpit Manhole Details - Brick Type**

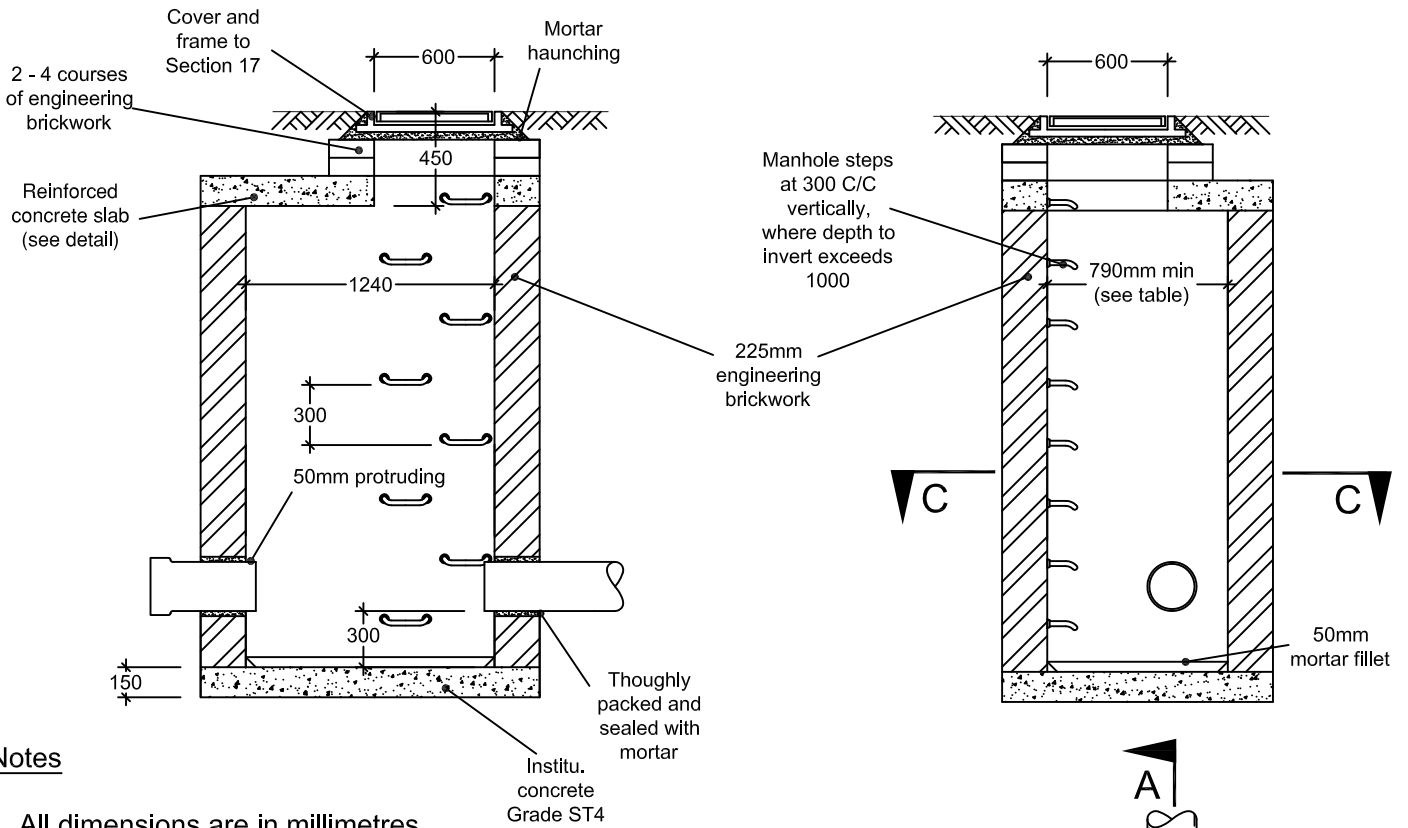

Notes

1. All dimensions are in millimetres.
2. Excess excavation backfill to be C7.5.

MANHOLE COVER SLAB

Concrete Grade -class 40/20 cover to reinforcement 50mm surface finish Class F2
 w- T12-02-125B y- T16-04-125B
 x- T16-03-125B z- T12-01-125B

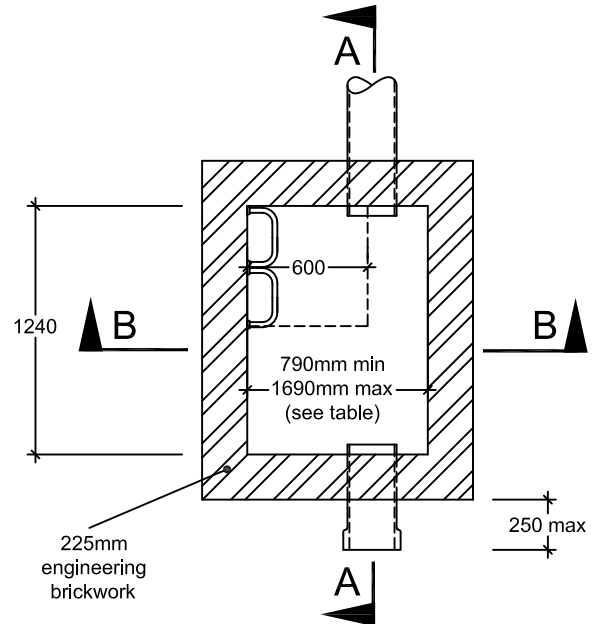
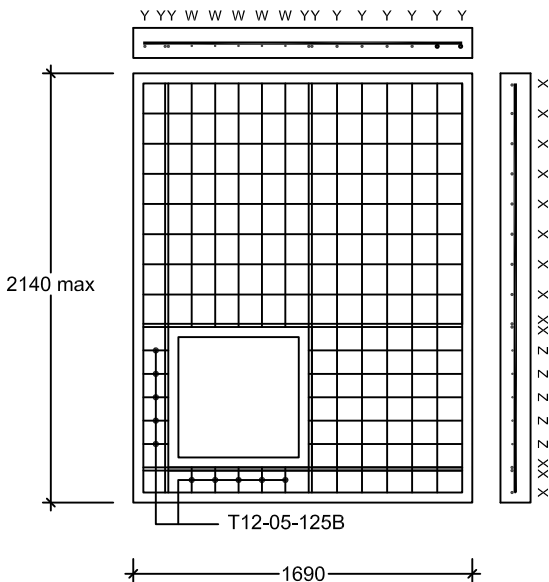
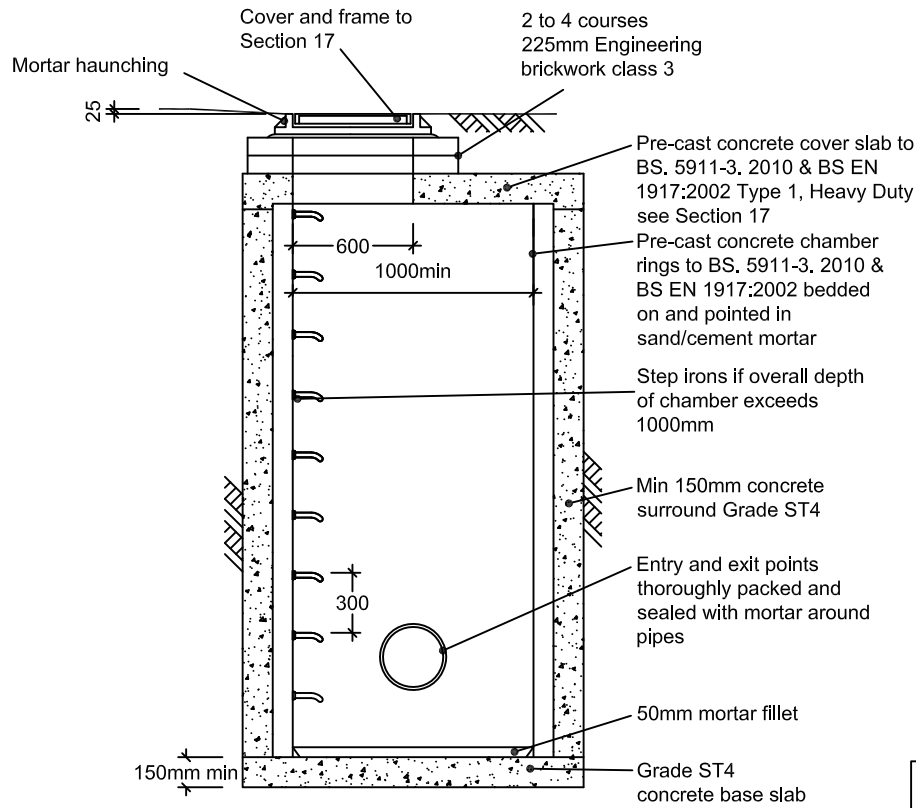

Table of dimensions

Internal dia. of outlet pipe (mm)	Min Internal width of brick manhole (mm)
150	790
225	900
300	900
375	1010
450	1125
525	1125
600	1240
675	1350
750	1350
825	1450
900	1575
975	1575
1050	1690



Job Title: Drainage - Manhole Details - Precast Concrete Type



Internal dia. of outlet pipe (mm)	Internal dia. precast concrete ring (mm)
150	1200
225	1200
300	1200
375	1200
450	1200
525	1350
600	1350
675	1350
750	1350
825	1500
900	1500
975	1800
1050	1800

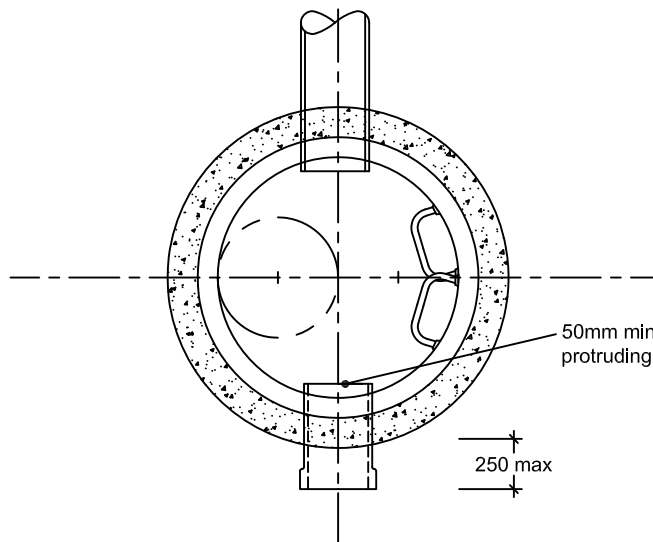

Table of dimensions

Notes:

Manhole rings, slab and ST 1 concrete to be made using sulphate resisting concrete.

Excess excavation concrete backfill to be ST 1 concrete



Job Title: Drainage - Soakaway Chamber Details

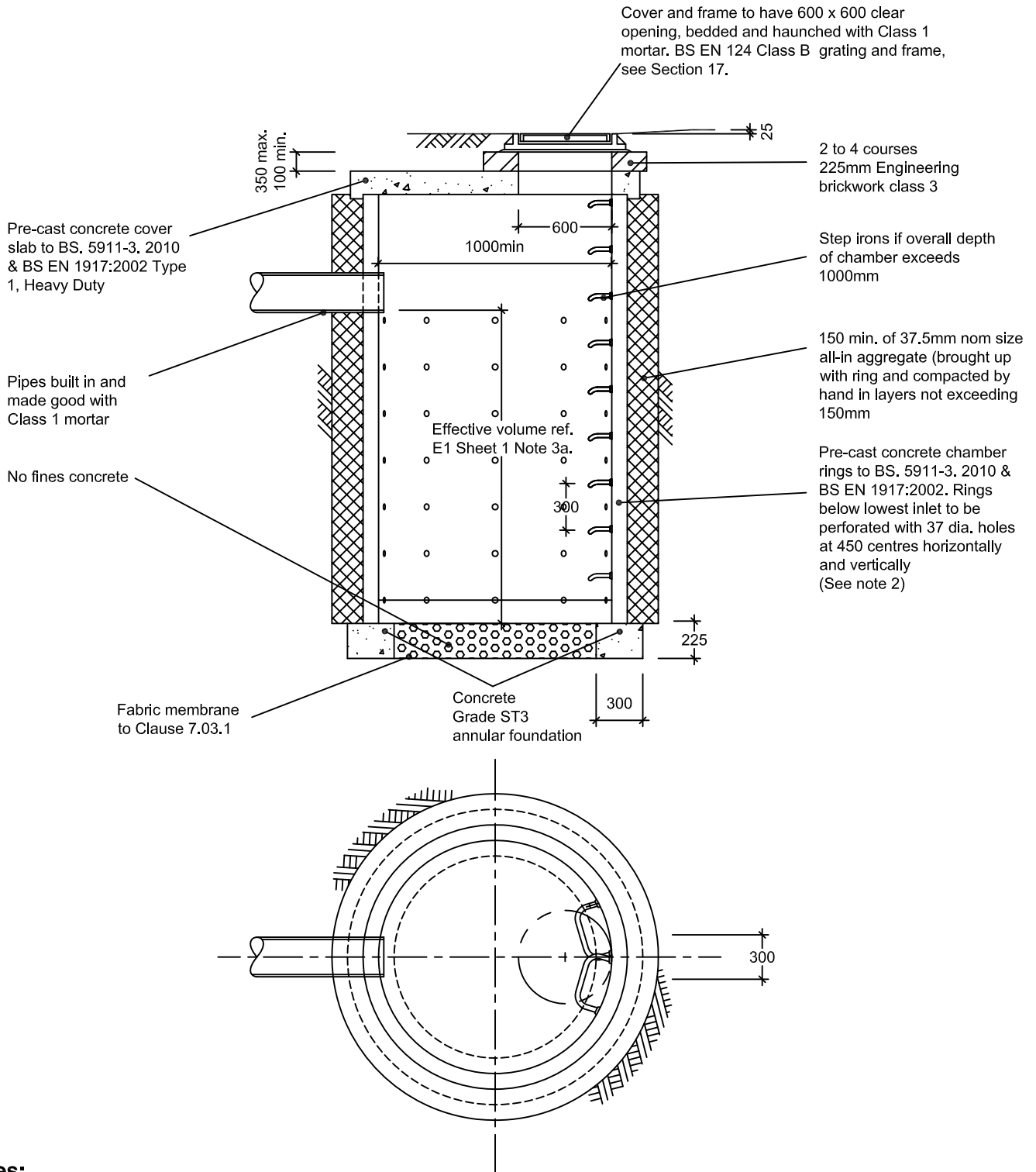

Notes:

1. Manhole rings, slab and ST3 concrete to be made using sulphate resisting concrete.
2. At least one perforated ring must be provided, with more perforated segments required to match depth of permeable strata up to the pipe invert.



Job Title:

Linked Soakaways diagrammatic layout

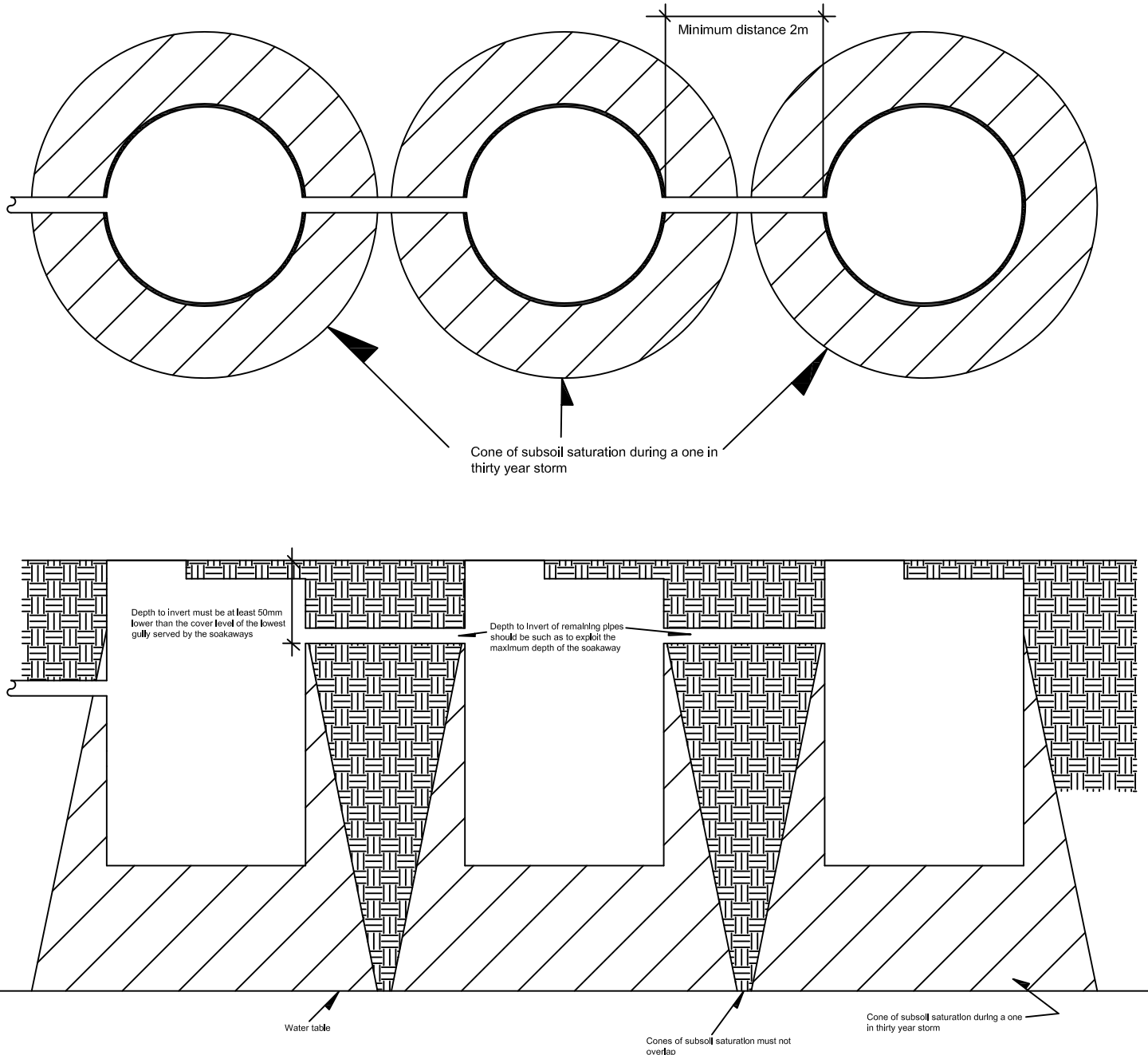

1. The maximum number of soakaways that will be permitted to be linked is three
2. All soakaways must be located at least 5m away from the existing/proposed carriageway/shared surface of the adopted public highway
3. All soakaways must be situated within the proposed adopted public highway

Date: 2018

Scale: N.T.S.

Drawing No : APPENDIX 16



Job Title: **Drainage - Trapped Carriageway Gully**

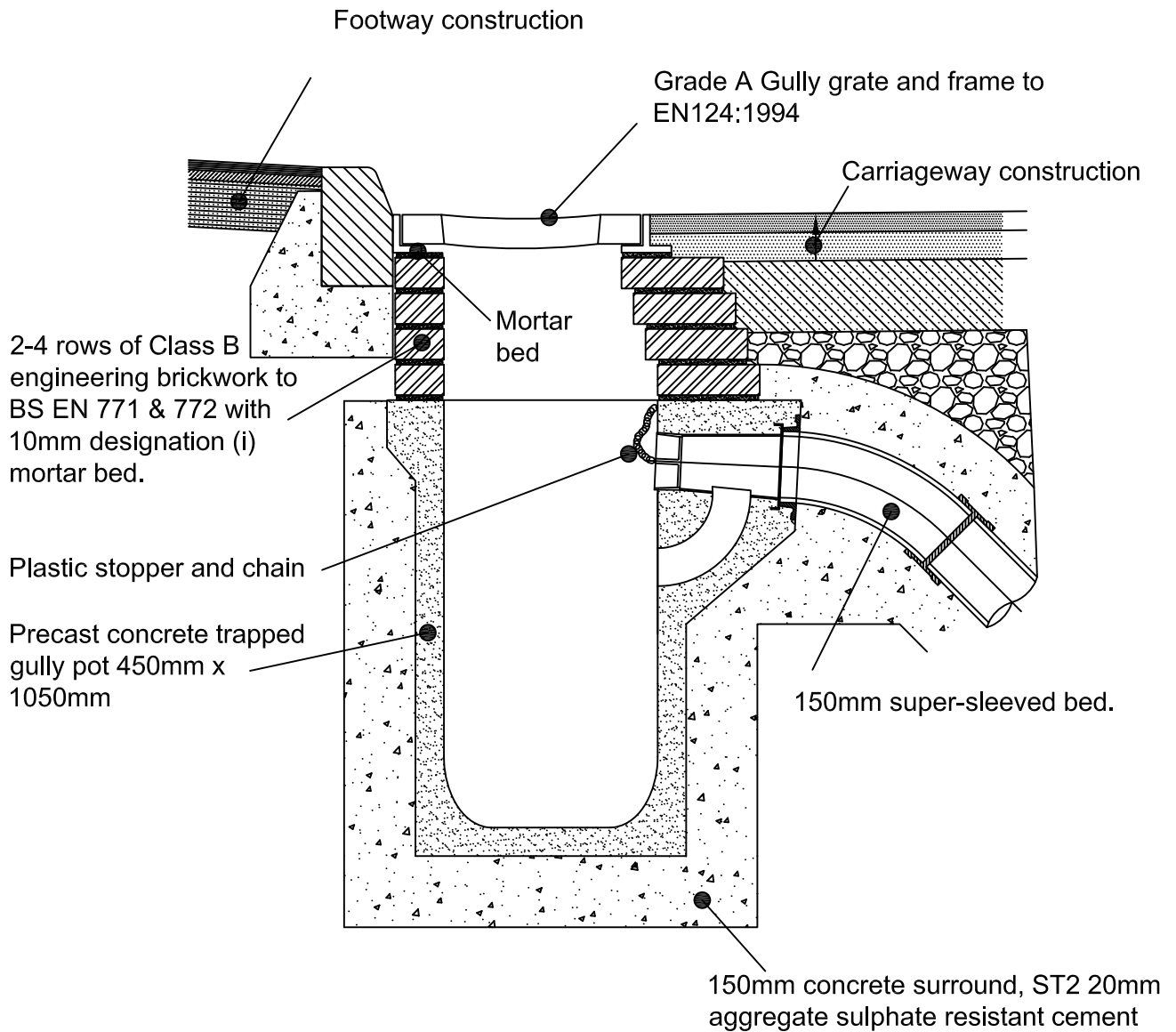

NOTES

1. Gully pot and outlet pipe to a depth of 1.2m to be surrounded in 150mm ST2 concrete.



Job Title: **Box culvert section under adopted public highway**

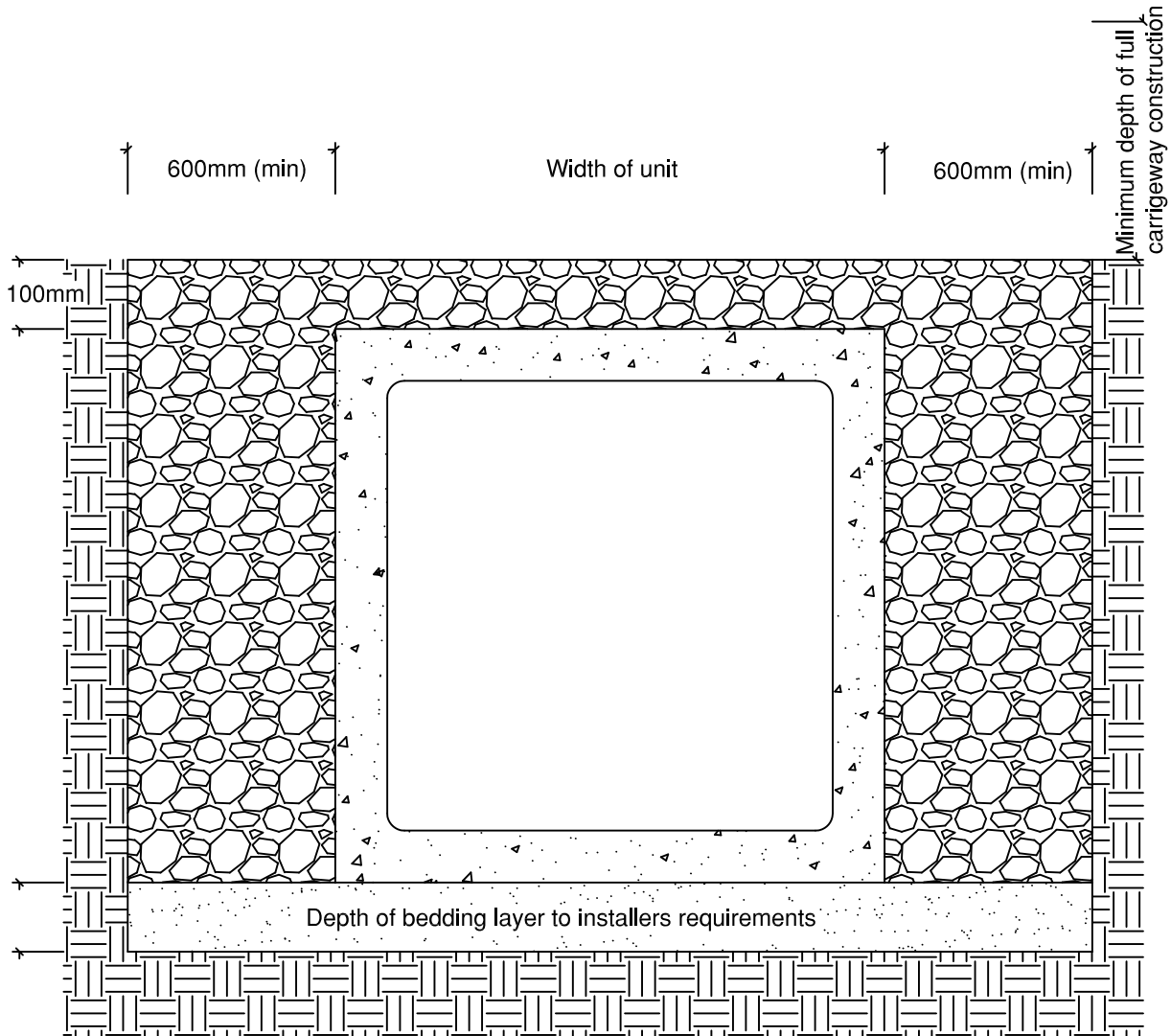

Notes

1. The sides and base of the excavation shall be trimmed, leveled and shaped so that there are no under cuts, irregular slopes, bows or similar disruptions .
2. The back fill to the side of the box culvert and the capping layer to the highway construction shall be a 6N material.
3. The top of the box culvert shall be at least 100mm below the lowest level of the highway construction material; this depth will be dependant on the CBR values of the site. The capping shall be a 6N material.



Job Title: **Trench reinstatement in existing adopted public highway only**

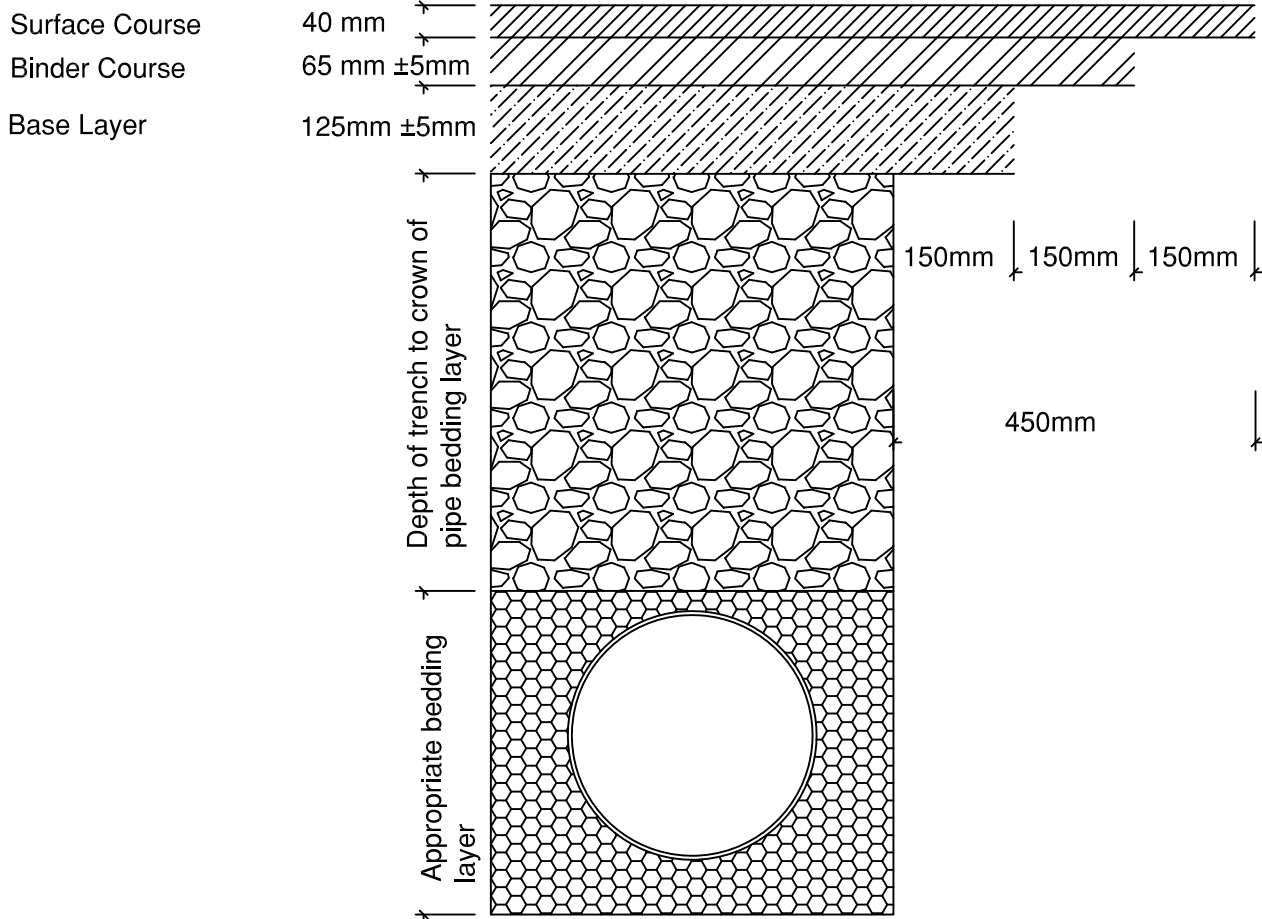

Notes

1. The stepping of the reinstatement shall be undertaken on both sides of the trench.
2. The edges of the reinstatement shall be sealed using hot pitch with a minimum width of 40mm.
3. The total bound bituminous or asphalt thickness must be at least 215mm.
4. The pipe bedding shall comply with Manual of Contract Documents for Highway Works Vol. 3 drawing F1, type Z if less than 1.2m from the highway surface or type S in all other cases. All backfill above the bedding layer shall be granular material to clause 803 laid in 150mm thick layers.



Job Title: **Typical Lighting Unit Positions**

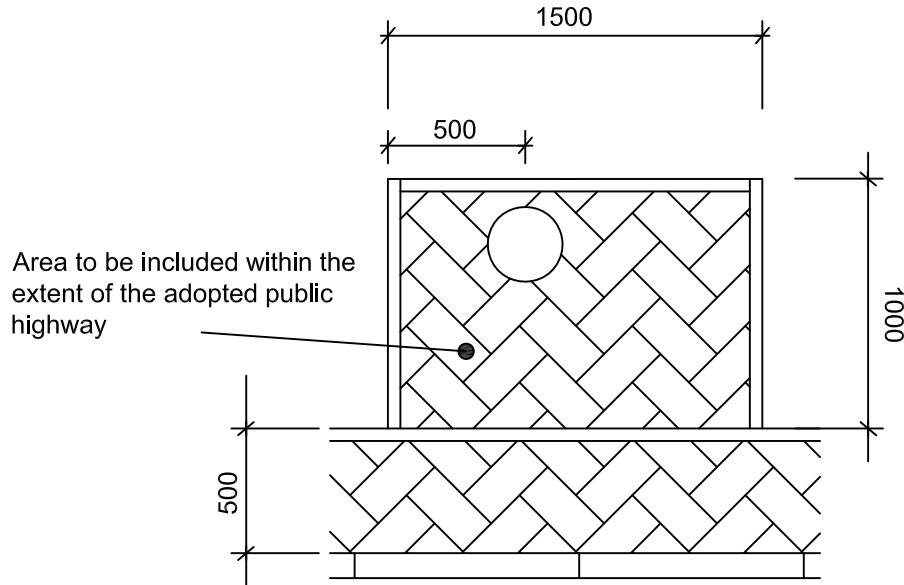

Location of Lighting Column
adjacent to a service strip

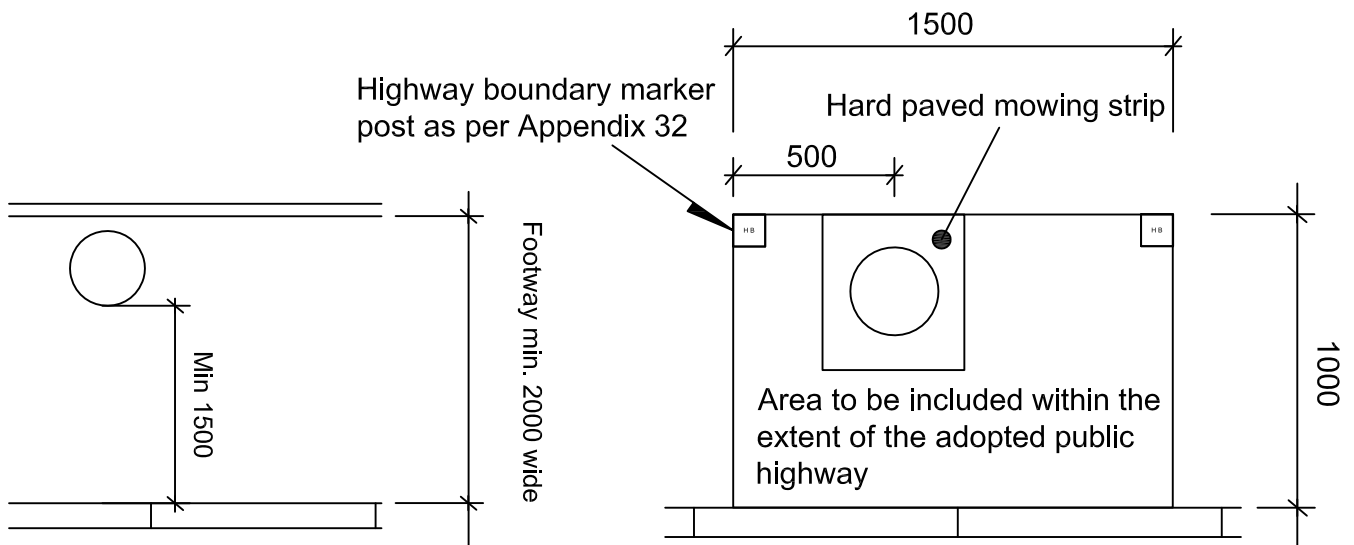

Location of Lighting Column
within a footway

Location of Lighting Column within grass
verge adjacent to carriageway

1. All doors to lighting columns must be positioned facing away from the on coming traffic, so that the operative faces the on coming traffic when working on the column



Job Title: **Timber Bollard Detail**

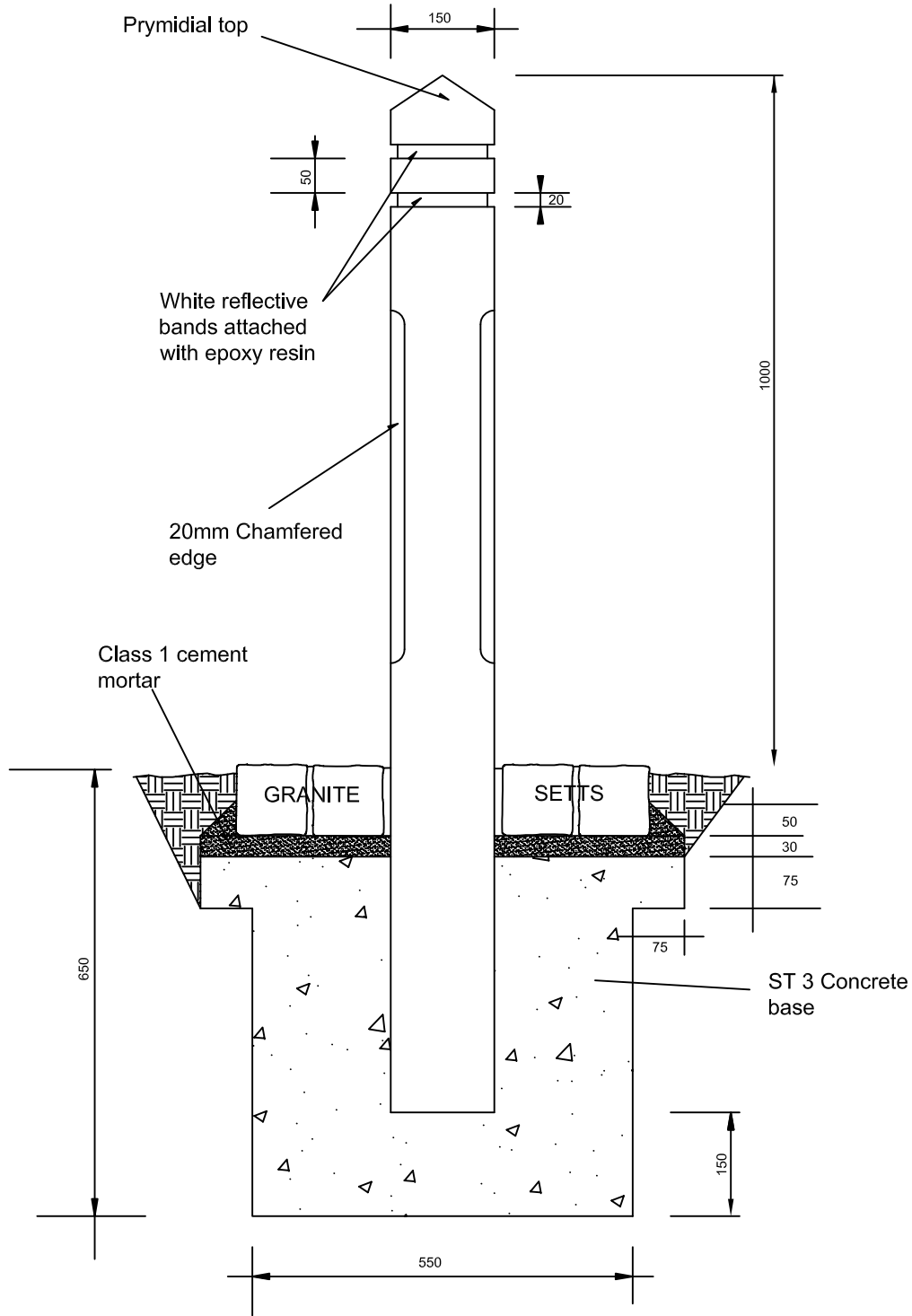



Job Title: **Public Utilities - Preferred Layout shared surface**

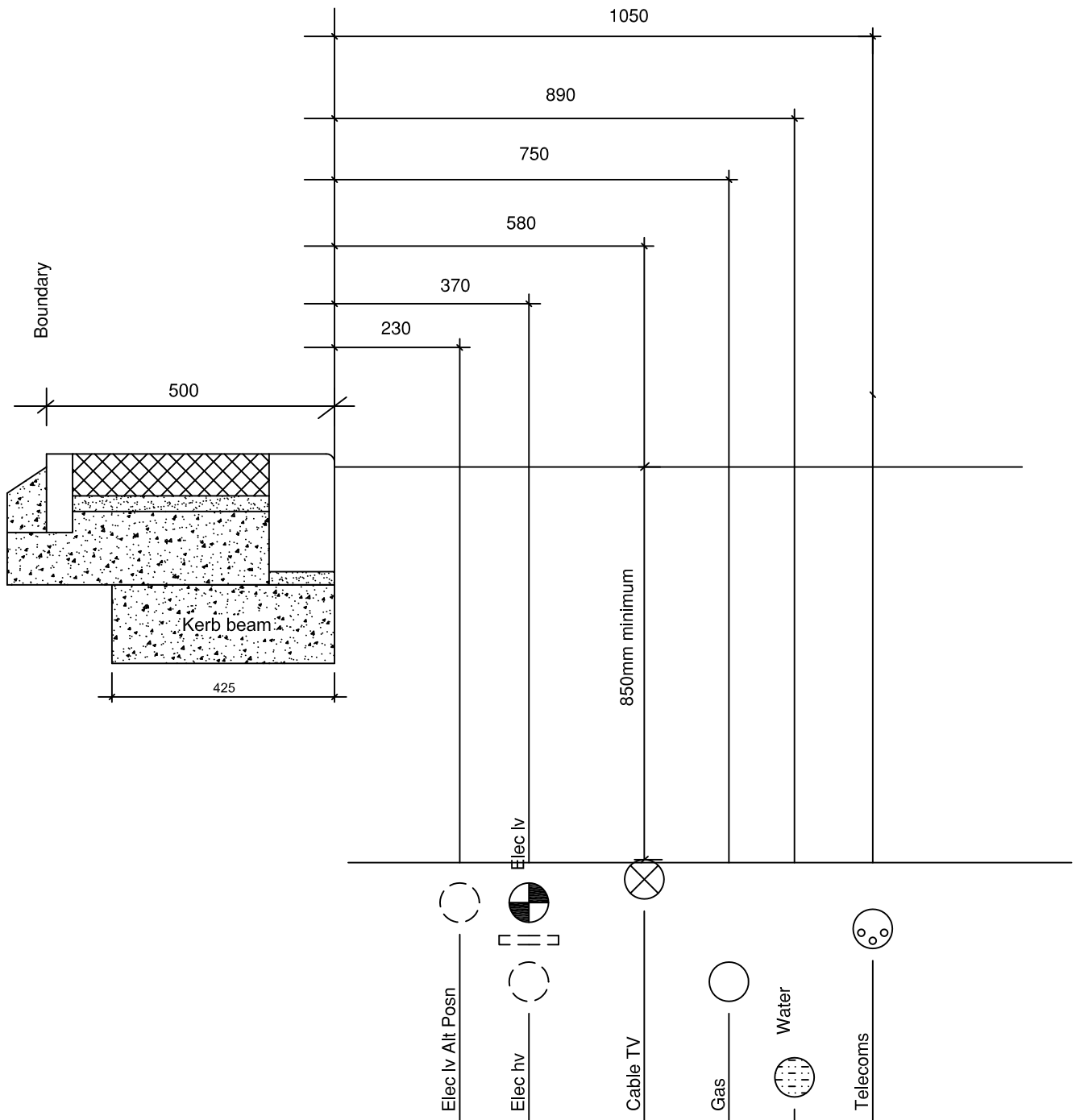

Notes

1. Preferred layout for mains in an 6000mm minimum wide shared surface for new works, (where this width is to be provided as part of the approved layout).
2. The Developer's attention is drawn to the economic advantages of utilising "common-trenching" techniques for installation of services wherever practicable.
3. The developer will ensure that the service boxes to the Public Utilities plant are orientated so that they are in line with any blockwork areas, avoid dropped kerbs (of any type) and are in general straight to the kerb line.



Job Title: **Extruded Kerb Beam**

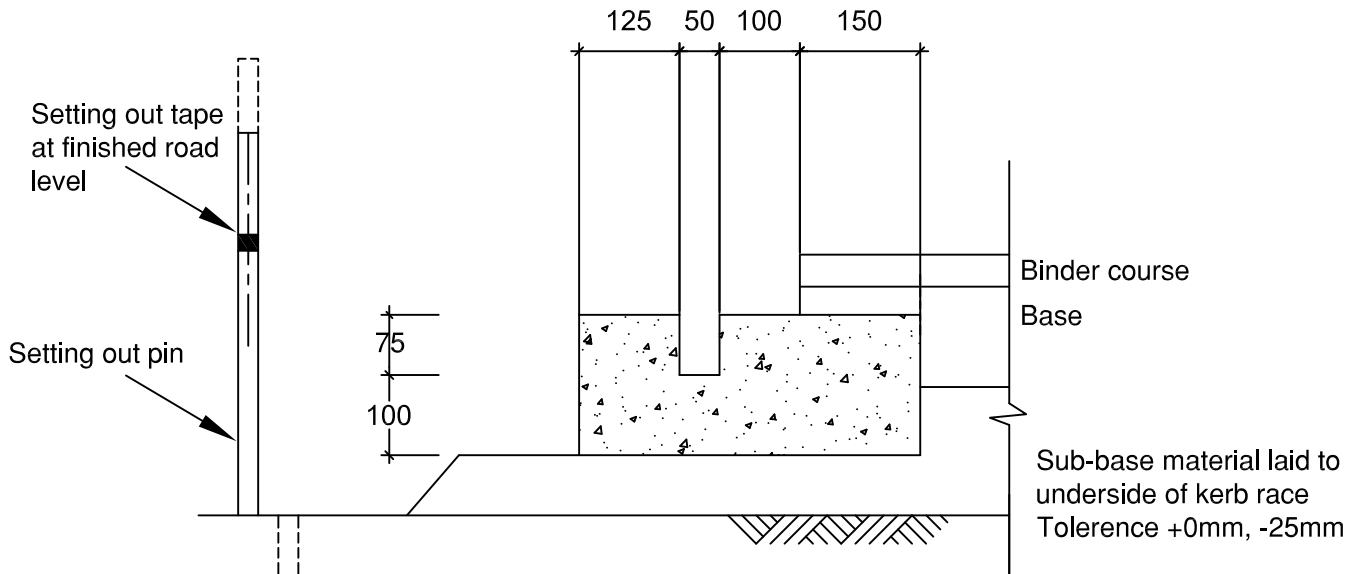

Stage 1 (Kerb race extrusion)

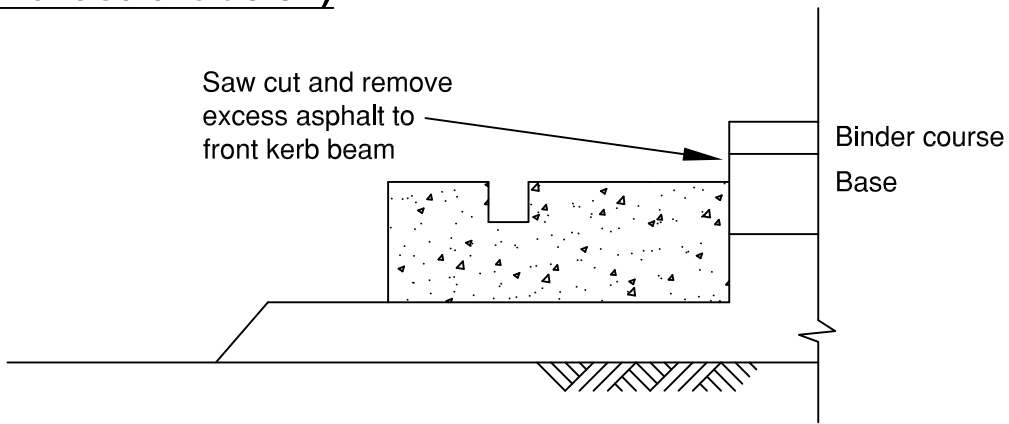

Stage 2 (Cut back bituminous layers)

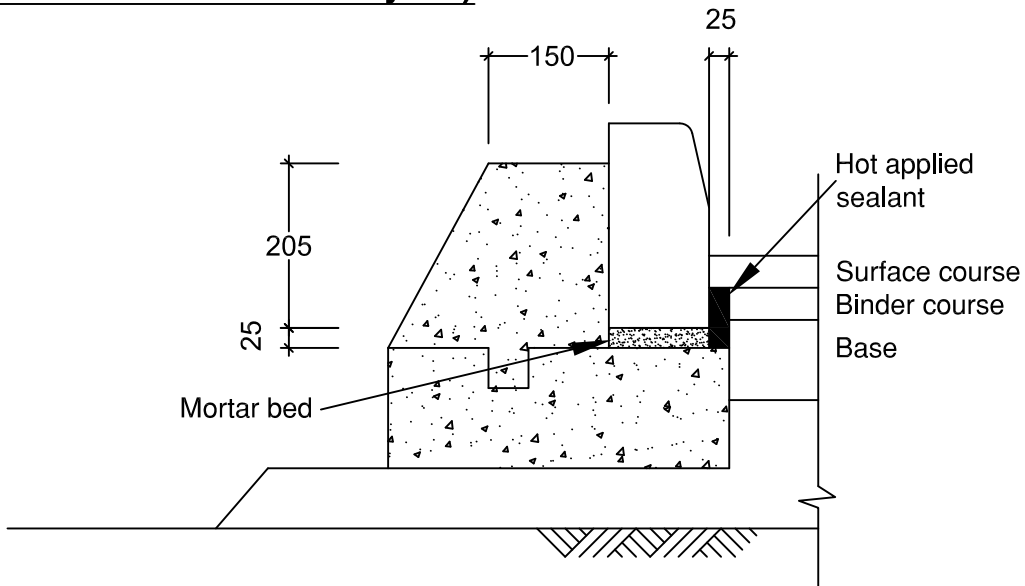

Stage 3 (Kerb, backing and sealing front of kerb)



Job Title: **Pavement Foundation Testing Regime**

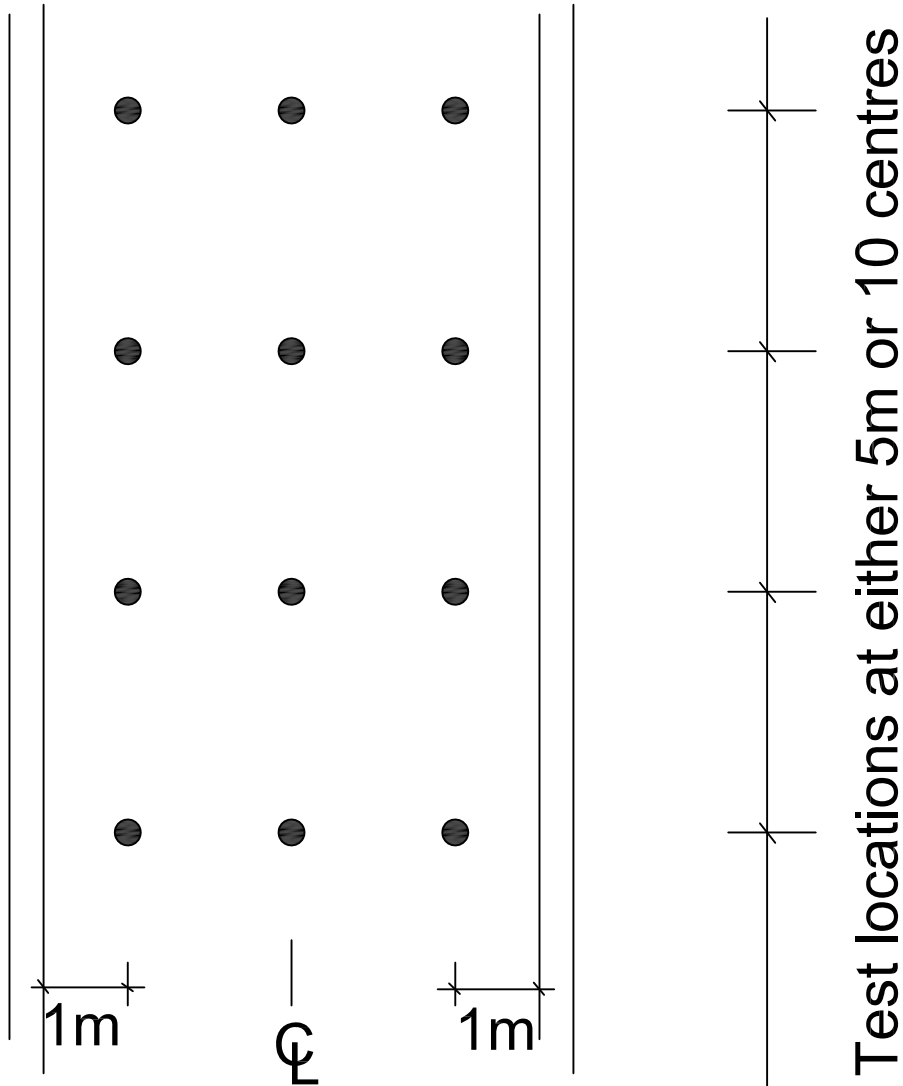



Job Title: **Tree pit in hard paving**

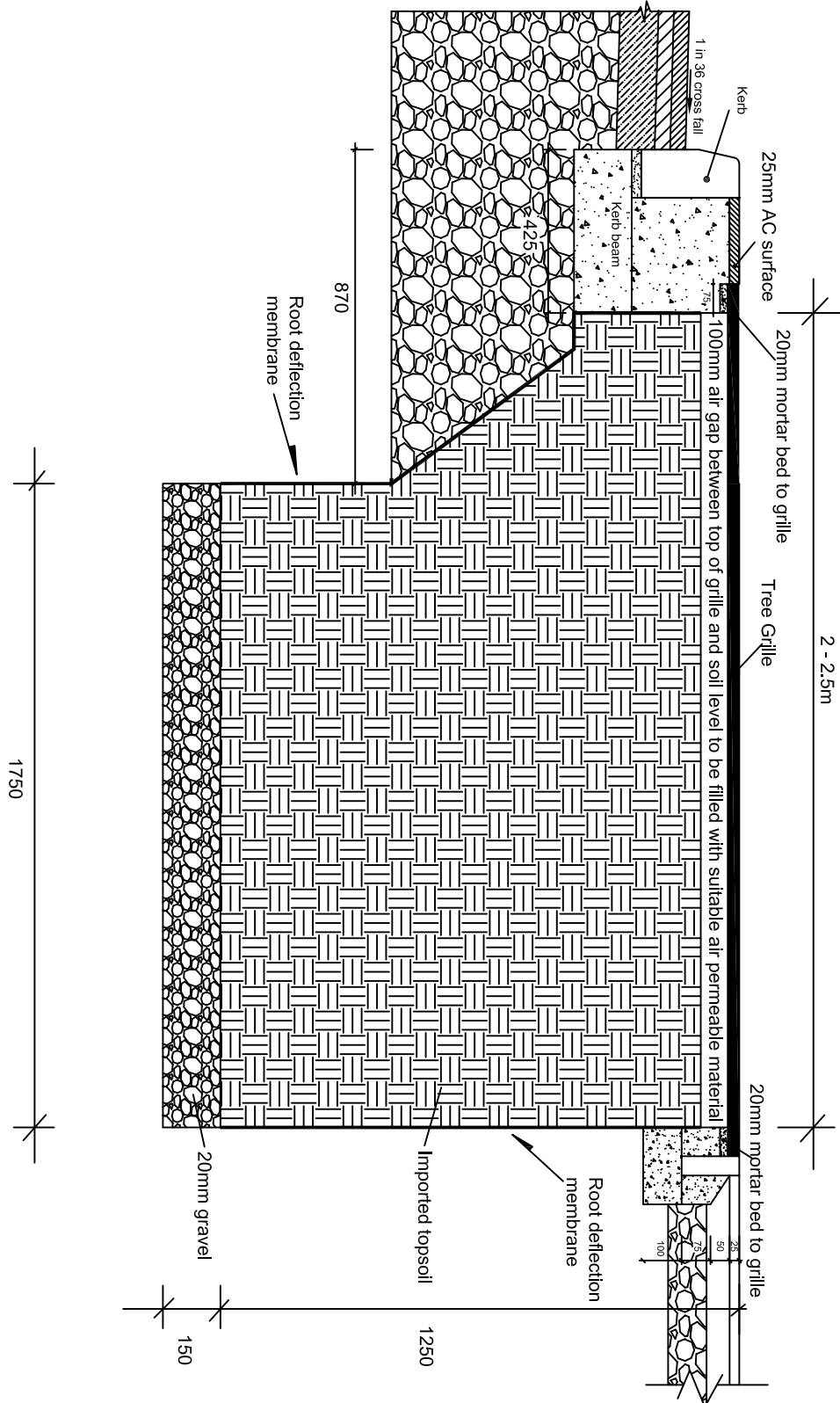



Job Title: **Tree pit in soft area**

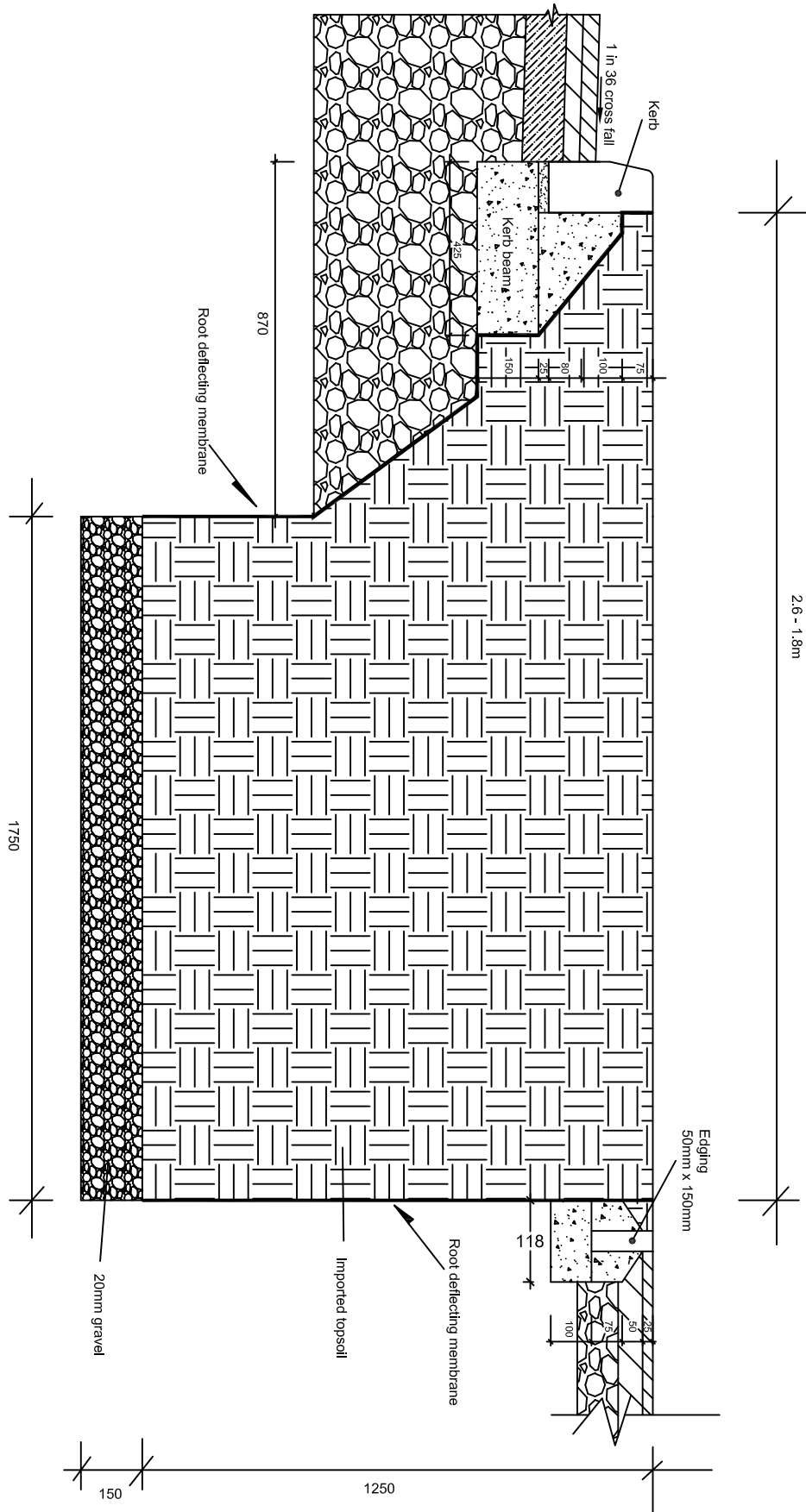



Job Title: **Tree Grille detail**

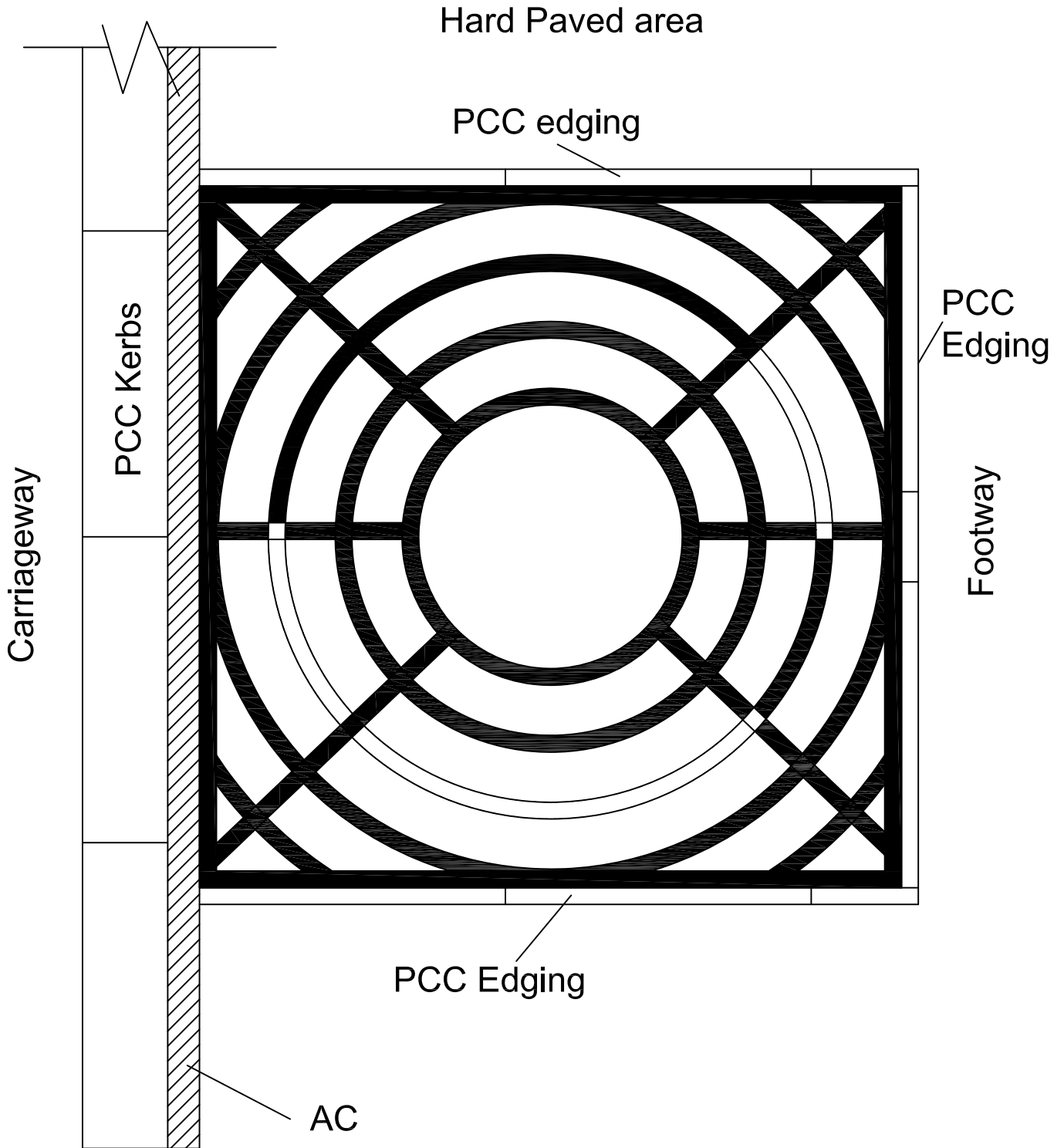

1. The tree grille must be at least 2 sq.m in area



Job Title: **Preferred private drive drainage detail**

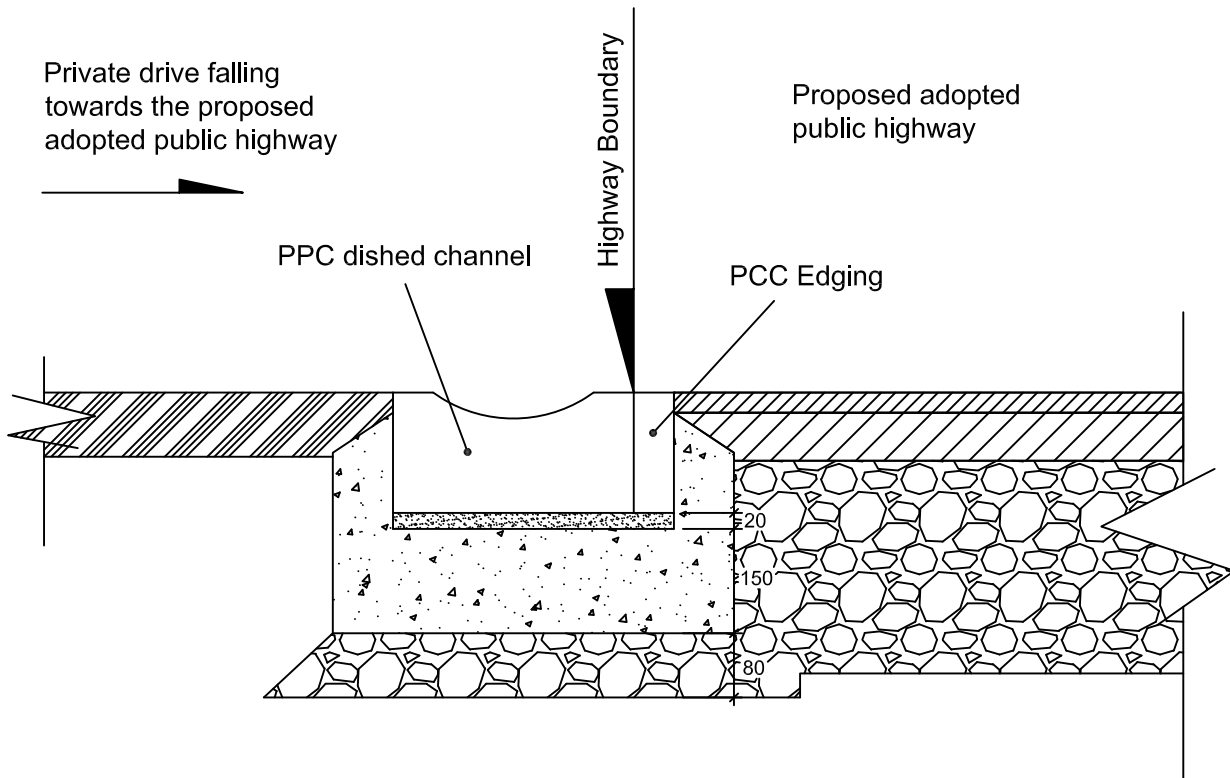

Notes:

1. Dished channels shall be installed between any areas of private land that fall towards the proposed adopted highway
2. The precast concrete dished channel shall fall to a soakaway or piped connexion to the private system on the site, no private water will be permitted into or on to the proposed adopted public highway.
3. The dished channel shall be laid on 20mm of class 1 mortar to allow a suitable fall to be created.
4. All dimensions are in millimetres



Job Title: **Highway Boundary marker (in soft)**

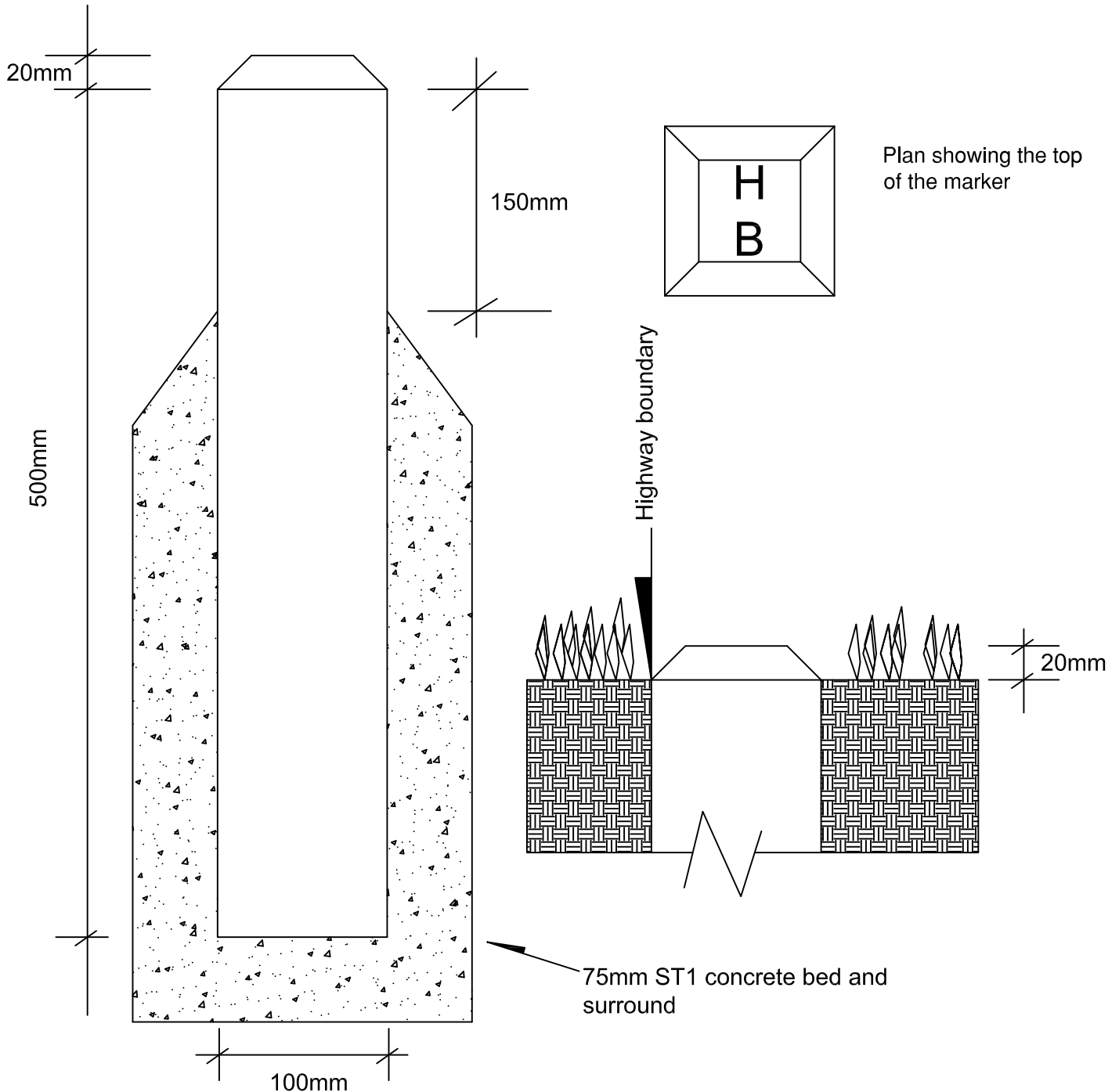

1. The boundary maker shall be manufactured in sulphate resisting pre-cast ST3 Concrete
2. The X height of the letters shall be 20mm and shall be written in Ariel Font with a minimum depth of 5mm
3. The boundary marker shall be installed so that it projects 20mm above the finished grass level in verge or soil level in a planting area.



Job Title: **General Cross Section**

GENERAL CROSS-SECTION

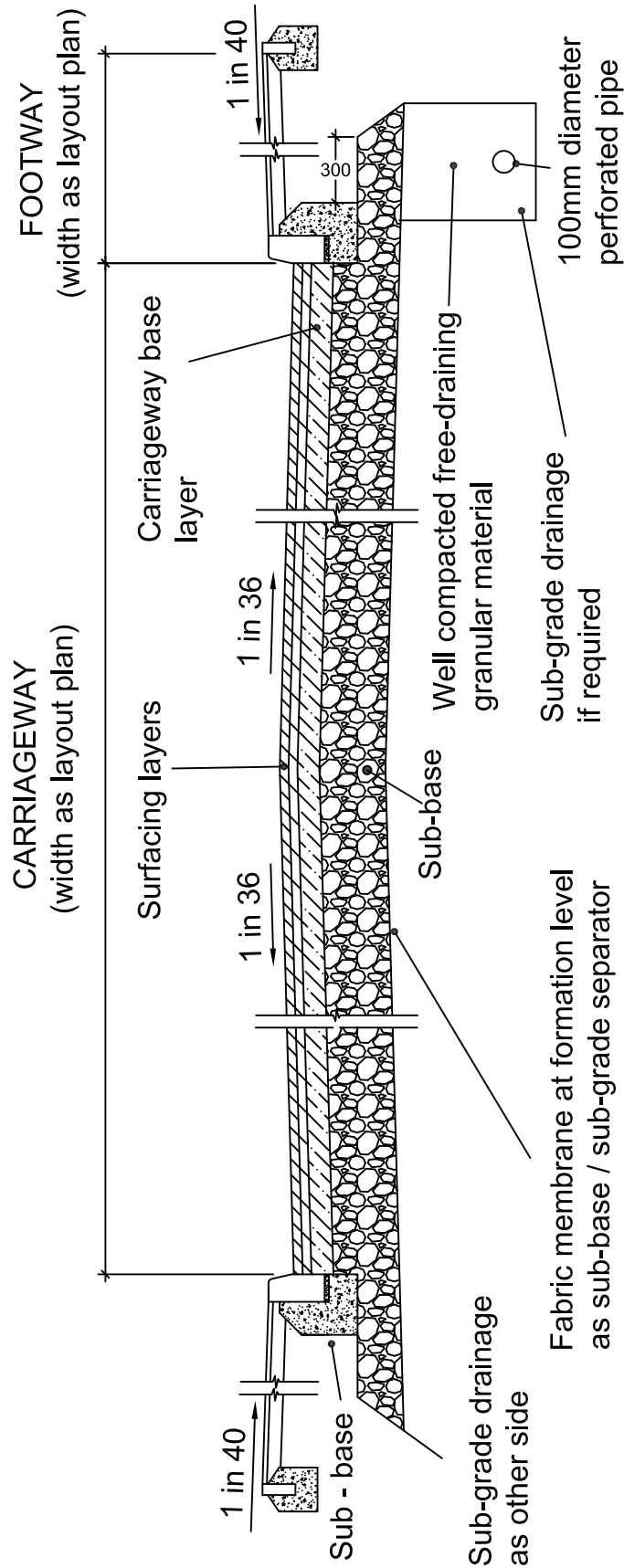



Job Title: **General Cross Section Shared Surface**

GENERAL CROSS-SECTION SHARED SURFACE

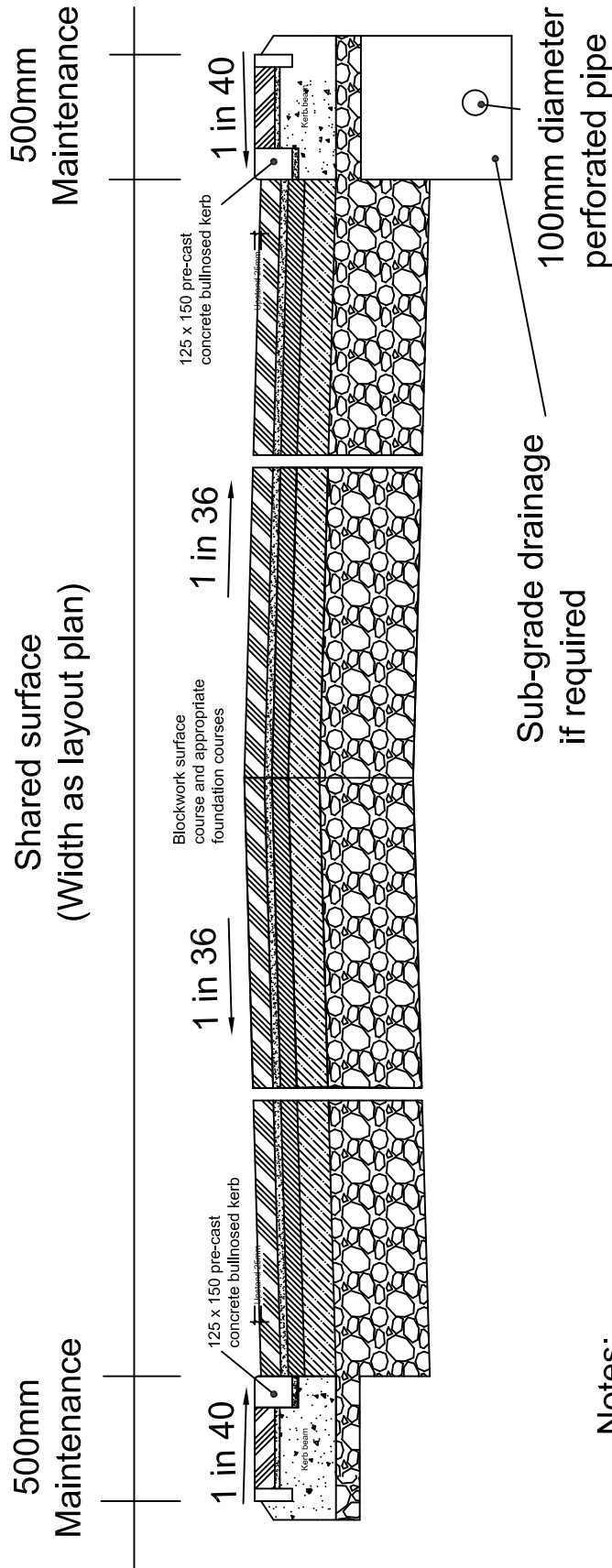

Notes:

1. The surface course of a shared surface must be blockwork
2. The Maintenance Strip is to enable the Highway Authority to maintain the kerb line and shall not be used for the installation of third party plant. The maintenance strip shall be hard paved.
3. For details of the Highway Boundary marker see appendix 31